

JVC

SERVICE MANUAL

COMPACT COMPONENT SYSTEM

CA-M30BK

Pickup	OPTIMA-5
CD signal processor / CD servo LSI	MN662720RB AN8803SB

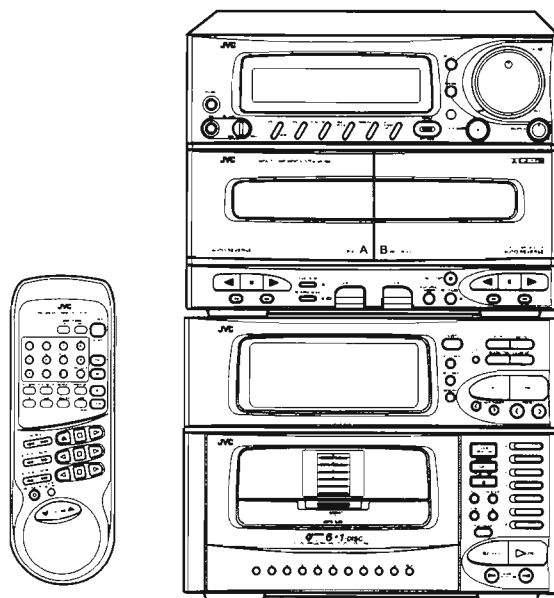

COMPACT
disc
DIGITAL AUDIO

Area Suffix

A	Australia
BS	the U.K.
C	Canada
E	Continental Europe
G	Germany
J	the U.S.A.
VX	East Europe
U	Other Area

Contents

Safety Precautions	2	DX-M30BK	19
Important for Laser Products	3	XT-M30BK	41
Instruction Book	4	Parts List	77

Safety Precautions

1. The design of this product contains special hardware and many circuits and components specially for safety purposes. For continued protection, no changes should be made to the original design unless authorized in writing by the manufacturer. Replacement parts must be identical to those used in the original circuits. Services should be performed by qualified personnel only.
2. Alterations of the design or circuitry of the product should not be made. Any design alterations of the product should not be made. Any design alterations or additions will void the manufacturer's warranty and will further relieve the manufacture of responsibility for personal injury or property damage resulting therefrom.
3. Many electrical and mechanical parts in the products have special safety-related characteristics. These characteristics are often not evident from visual inspection nor can the protection afforded by them necessarily be obtained by using replacement components rated for higher voltage, wattage, etc. Replacement parts which have these special safety characteristics are identified in the Parts List of Service Manual. Electrical components having such features are identified by shading on the schematics and by (Δ) on the Parts List in the Service Manual. The use of a substitute replacement which does not have the same safety characteristics as the recommended replacement parts shown in the Parts List of Service Manual may create shock, fire, or other hazards.
4. The leads in the products are routed and dressed with ties, clamps, tubings, barriers and the like to be separated from live parts, high temperature parts, moving parts and/or sharp edges for the prevention of electric shock and fire hazard. When service is required, the original lead routing and dress should be observed, and it should be confirmed that they have been returned to normal, after re-assembling.

5. Leakage current check (Electrical shock hazard testing)

After re-assembling the product, always perform an isolation check on the exposed metal parts of the product (antenna terminals, knobs, metal cabinet, screw heads, headphone jack, control shafts, etc.) to be sure the product is safe to operate without danger of electrical shock.

Do not use a line isolation transformer during this check.

- Plug the AC line cord directly into the AC outlet. Using a "Leakage Current Tester", measure the leakage current from each exposed metal parts of the cabinet, particularly any exposed metal part having a return path to the chassis, to a known good earth ground. Any leakage current must not exceed 0.5mA AC (r.m.s.).

● Alternate check method

Plug the AC line cord directly into the AC outlet. Use an AC voltmeter having, 1,000 ohms per volt or more sensitivity in the following manner. Connect a 1,500 Ω 10 W resistor paralleled by a 0.15 μ F AC-type capacitor between an exposed metal part and a known good earth ground.

Measure the AC voltage across the resistor with the AC voltmeter.

Move the resistor connection to each exposed metal part, particularly any exposed metal part having a return path to the chassis, and measure the AC voltage across the resistor.

Now, reverse the plug in the AC outlet and repeat each measurement. Any voltage measured must not exceed 0.75 V AC (r.m.s.). This corresponds to 0.5 mA AC (r.m.s.).

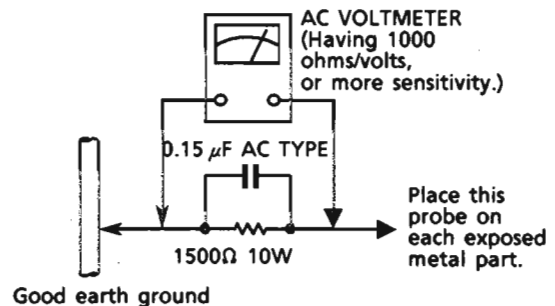

Warning

1. This equipment has been designed and manufactured to meet international safety standards.
2. It is the legal responsibility of the repairer to ensure that these safety standards are maintained.
3. Repairs must be made in accordance with the relevant safety standards.
4. It is essential that safety critical components are replaced by approved parts.
5. If mains voltage selector is provided, check setting for local voltage.

Important for Laser Products

1. **CLASS 1 LASER PRODUCT**
2. **DANGER** : Invisible laser radiation when open and interlock failed or defeated. Avoid direct exposure to beam.
3. **CAUTION** : There are no serviceable parts inside the Laser Unit. Do not disassemble the Laser Unit. Replace the complete Laser Unit if it malfunctions.
4. **CAUTION** : The compact disc player uses invisible laser radiation and is equipped with safety switches which prevent emission of radiation when the drawer is open and the safety interlocks have failed or are defeated. It is dangerous to defeat the safety switches.
5. **CAUTION** : If safety switches malfunction, the laser is able to function.
6. **CAUTION** : Use of controls, adjustments or performance of procedures other than those specified herein may result in hazardous radiation exposure.
7. **CAUTION** : The compact disc player provides a laser diode of wavelength 780-790nm and optical output power typical 3mW at the laser diode.

WARNING : Osynlig laserstrålning när denna del är öppnad och spärren är urkopplad. Betrakta ej strålen.

VARO : Avattaessa ja suojalukitus ohitettaessa olet alttiina näkymättömälle lasersäteilylle. Älä katso säteeseen.

ADVARSEL : Usynlig laserstrålning ved åbning, når sikkerhedsafbrydere er ude af funktion. Undgå udsættelse for stråling.

ADVARSEL : Usynlig laserstrålning ved åbning, når sikkerhedsbryteren er avsluttet. unngå utsettelse for stråling.

REPRODUCTION AND POSITION OF LABELS

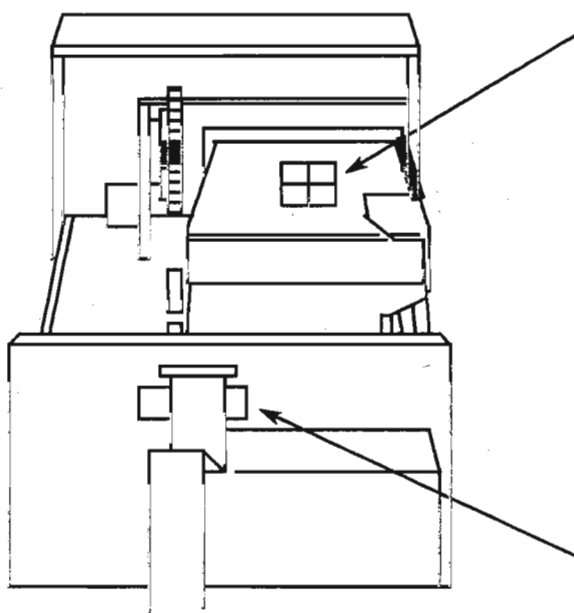

WARNING LABEL

(Except for the U. S. A.)

DANGER: Invisible laser radiation when open and interlock failed or defeated. AVOID DIRECT EXPOSURE TO BEAM. (e)

WARNING: Osynlig laserstrålning när denna del är öppnad och spärren är urkopplad. Betrakta ej strålen. (s)

ADVARSEL: Usynlig laserstrålning ved åbning, når sikkerhedsafbrydere er ude af funktion. Undgå udsættelse for stråling. (d)

VARO: Avattaessa ja suojalukitus ohitettaessa olet alttiina näkymättömälle lasersäteilylle. Älä katso säteeseen. (f)

**CLASS 1
LASER PRODUCT**

CLASSIFICATION LABEL

(Except for the U. S. A. and Canada)

English | Español | Português | 中文

Control Panel and Remote— Illustrations
Ilustraciones del panel de control y del controlador remoto
Ilustrações— Painel de comando e controle remoto
控制面板與遙控器—圖解

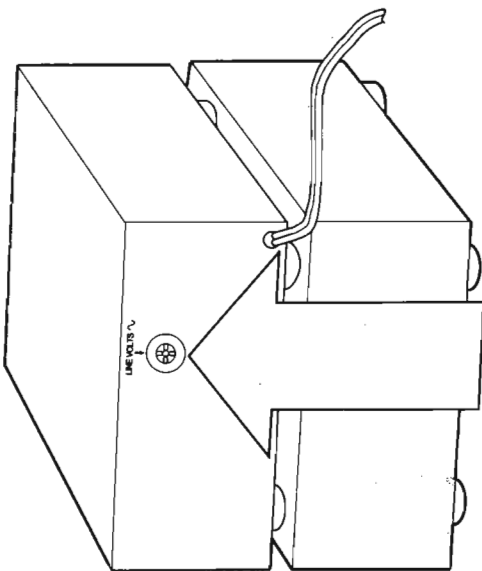

IMPORTANT for mains (AC) line
BEFORE PLUGGING IN, do check so your mains (AC) line voltage corresponds with the position of the voltage selector switch provided on the outside of this equipment and, if different, reset with a Phillips type screw driver, to prevent from a damage or risk of fire/electric shock.

INFORMACION IMPORTANTE SOBRE LA TENSION DE LINEA
ANTES DE CONECTAR EL EQUIPO, compruebe que la tensión de línea (c.a.) se corresponde con la posición del selector de tensión situado en el exterior del equipo. Si no coincide, ajuste la tensión correcta mediante un destornillador con punta de estrella, con el fin de evitar el riesgo de incendio y/o descarga eléctrica.

IMPORTANTE para fazer a ligação à corrente elétrica (CA):
ANTES DE LIGAR A CORRENTE ELÉTRICA, verifique se a voltagem desta corresponde à indicada no comutador de seleção da voltagem existente na parte exterior do equipamento e, caso seja diferente, selecione a voltagem correta com uma chave de fenda philips, a fim de evitar danos e riscos de choque elétrico ou de incêndio.

主 (AC) 電源線的重要注意
連接前，請檢查您的主 (AC) 電源線電壓是否與本機外殼上的電壓選擇開關的位置一致。如果不同，請用十字型螺絲刀進行調整，以免發生損壞或火災/觸電危險。

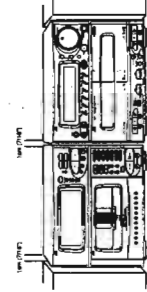
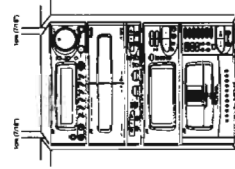
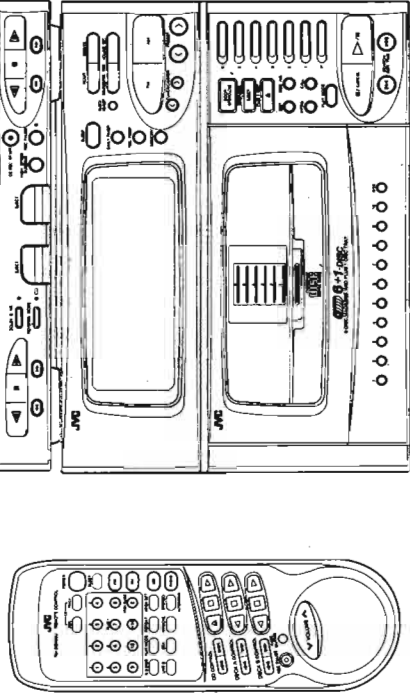

How to Use the Supplied Wire for Better AM Reception

The AM loop antenna may not work well because stations are far from your area. If this happens, you can use the supplied wire as illustrated below. If this does not work well either, connect an outside wire antenna then (see page 4).

Utilización del cable suministrado para obtener una mejor recepción de AM

La antena de cuadro de AM puede que no funcione bien si las emisoras están lejos de su zona. Si esto ocurre, puede utilizar el cable suministrado. Si así no funcionara bien, conecte una antena de cable exterior (consulte la página 4).

Como utilizar o fio isolado fornecido para melhorar a recepção de AM

A antena de quadro AM poderá não funcionar adequadamente devido a longa distância das estações. Caso isto ocorra, utilize o fio isolado fornecido como ilustrado abaixo. Caso isso não funcione também, conecte um cabo de antena externa (consulte a página 4).

如何使用隨機供應的導線取得AM最佳的接收效果

由於電台廣播站的距離，以致AM廣播效果不佳。如果這種情況發生，您可根據下圖所示，使用隨機供應的導線。如果接收效果不佳，請連接戶外天線（請參閱第4頁）。

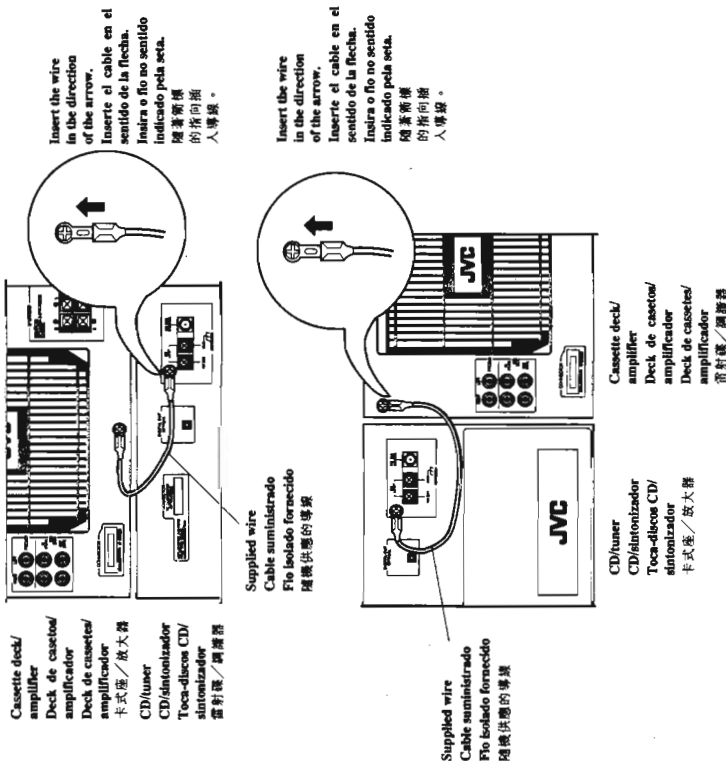

Checking the Tuner Reception While in Japan

The CA-M30BK comes with a built-in program to preset the AM and FM stations anywhere in Japan. This function is only supported in areas with Japanese telephone area codes. Tables of area codes and the preset stations for each are on the following pages. Upon shipment, the station of the Tokyo (03) area have been preset.

Area Guide Preset functions only when the CA-M30BK is set to 9 kHz frequency spacing. (See page 7.)

You use this program by entering your Japanese telephone area code with the Remote using the following procedure:

1. Press AM or FM on the Remote.
 2. Press AREA GUIDE. "TEL 0" appears and "MEMORY" blinks on the CD/tuner display.
 3. Enter your telephone area code using the 10 key pad. You don't need to enter the first 0 which your area code starts with, since pressing AREA GUIDE takes care of the first 0.
 4. Press AREA SET.
- The AM stations which were set at the factory for this area code will now be displayed and set.
- As soon the AM stations are set, the Unit enters the FM preset mode, and automatically sets FM stations (see note below). You can change them using the procedure under "Presetting Stations."
- Wait until the entire procedure is finished ("MEMORY" goes off and the FM station frequency selected last appears on the display and the radio is tuned to this last FM station) before doing anything else with the CA-M30BK, or you may have to shut the Unit off, and start over.

Note on AM Preset

Although you can preset up to 10 AM stations, the Area Guide function leaves position 10 blank, as well as those marked "...", in the table. You can set other stations in these positions if you wish. If reception of stations from a neighboring area is better, you can enter that area code instead of your own, and receive those stations.

Note on FM Preset

The CA-M30BK can preset only the FM stations with a signal which is strong enough to be received, therefore, you will not be able to preset all the stations of your local area. On the other hand, a certain station may be preset at some different positions because it uses different frequencies to broadcast its programs.

Comprobación de la recepción del sintonizador en Japón

El CA-M30BK dispone de un programa incorporado para memorizar las emisoras de AM y FM en cualquier parte de Japón. Esta función se efectúa solamente en zonas con códigos telefónicos del área. Las tablas de códigos de área y de emisoras memorizadas para cada una se indican en las páginas siguientes. Una vez la unidad sale de fábrica se han programado emisoras del área de Tokio (03).

El ajuste de guía del área funciona solamente cuando el CA-M30BK está ajustado a espacio de frecuencia de 9 kHz. (Vea la página 7.)

Usará podrá emplear este programa introduciendo su código telefónico de área con el controlador remoto de acuerdo al procedimiento siguiente:

1. Presione AM o FM del controlador remoto.
 2. Presione AREA GUIDE. "TEL 0" aparecerá y "MEMORY" parpadeará en el visualizador del CD/sintonizador.
 3. Introduzca el código telefónico del área usando el teclado de 10 teclas. No necesitará introducir el primer 0 del código de área ya que la introducción de AREA GUIDE se ocupa de este primer 0.
 4. Presione AREA SET.
- Las emisoras de AM que han sido ajustadas en fábrica para este código del área se visualizarán y ajustarán ahora.
- Tan pronto se ajustan las emisoras de AM, la unidad entrará en el modo de memorización de FM (consulte la nota de abajo) y ajustará automáticamente las emisoras de FM del área. Usted puede cambiarlas usando el procedimiento de "Programación de emisoras."
- Esperar hasta que el procedimiento entero termine ("MEMORY" se apagará y la frecuencia de la última emisoras de FM seleccionada aparecerá en el visualizador sintonizándose la radio a esta emisoras de FM) antes de hacer nada más con el CA-M30BK, o tendrá que desconectar la unidad y empezar de nuevo desde el principio.

Nota sobre la programación de AM

Aunque usted puede memorizar hasta 10 emisoras de AM, la función de guía del área deja la posición 10 en blanco, así como las marcadas con "...", en la tabla. Usted puede memorizar otras emisoras en estas posiciones si así lo desea. Si la recepción de las emisoras en un área adyacente es mejor, podrá introducir el código de área de la misma en lugar del código del área en la que se concentre y recibir tales emisoras.

Nota sobre la programación de FM

El CA-M30BK puede memorizar sólo las emisoras de FM con señal suficientemente fuerte como para ser recibida; por lo tanto, no podrá memorizar todas las emisoras de su área. Por otro lado, ciertas emisoras pueden ser memorizadas en algunas posiciones diferentes ya que utilizan diferentes frecuencias para radiodifundir los programas.

AM Station Table (West Japan)/Tabla de emisoras de AM (Oeste de Japón)
Tabela de estações AM (Oeste do Japão)/AM電台頻率表 (日本西部)

Area Code Código de área Código de região 地區代號	Prefecture Prefeitura Prefeitura 省份	Biggest city Ciudad más grande Mayor cidade 最大城市	P-1	P-2	P-3	P-4	P-5	P-6	P-7	P-8	P-9
06	OSAKA	OSAKA	538	666	828	1008	1143	1179	1314		
0730-0739	WAKAYAMA	WAKAYAMA	666	828	1008	1179	1314	1431			
075	KYOTO	KYOTO	666	828	1008	1143	1179	1314			
0760-0762	ISHIKAWA	ISHIKAWA	1107	1224	1386						
0763-0766	TOYAMA	TOYAMA	648	738	1035						
0760	ISHIKAWA	NANAO	540	1107	1386						
0767-0769	KYOTO, SHIGA	OTSU	666	828	1008	1143	1179	1215	1314		
0771-0775	FUKUI	FUKUI	864	927	1521						
0776-0779	HYOGO	KOBE	538	666	828	1008	1179	1314			
0790-0799	HIROSHIMA	HIROSHIMA	702	1071	1350						
081,082,083,084,085	YAMAGUCHI	YAMAGUCHI	675	765	1377	1575					
0830-0839	HIROSHIMA	ONOMICHI	720	999	1602						
0840-0849	SHIMANE	MATSUE	1296	1431	1593						
0851-0856	TOTTORI	YONAGO	900	963	1125	1368					
0857-0859	OKAYAMA	OKAYAMA	600	1386	1494						
0860-0869	HIROSHIMA	KAGAWA	828	1368	1449						
0870-0879	TOKUSHIMA	TOKUSHIMA	828	945	1269						
0881-0886	KOCHI	KOCHI	900	990	999	1152	1197				
0887-0889	EHIME	MATSUYAMA	846	963	1116	1512	1530				
0890-0899	FUKUOKA	FUKUOKA	612	1017	1278	1413					
092,093,094	NAGASAKI	NAGASAKI	684	819	873	1098	1233				
0950-0949	KUMAMOTO	KUMAMOTO	756	846	873	1197					
0960-0969	OKI	OKI									
0970-0979	OKI	OKI	819	873	1098						
0981-0987	MIZUAKI	MIZUAKI	540	621	873	936	1098				
098,0980	OKINAWA	NAHA	540	549	648	738	783	1125			
0988-0989	KAGOSHIMA	KAGOSHIMA	576	792	1107	1386					

G-9

AM Station Table (East Japan)/Tabla de emisoras de AM (Este de Japón)
Tabela de estações AM (Leste do Japão)/AM電台頻率表 (日本東部)

Area Code Código de área Código de região 地區代號	Prefecture Prefeitura Prefeitura 省份	Biggest city Ciudad más grande Mayor cidade 最大城市	P-1	P-2	P-3	P-4	P-5	P-6	P-7	P-8	P-9
011	HOKKAIDO	SAPPORO	567	675	747	864	900	945	1197	1287	1440
0121-0149	HOKKAIDO	ABASHIRI	702	936	1188	1449					
0153-0156	HOKKAIDO	KUSHIRO	585	603	918	1152	1269	1404			
0159	HOKKAIDO	KITAMI	702	747	1188	1449	1485				
0157-0159	HOKKAIDO	ASHIBIKAWA	567	747	792	864	927	1287	1440		
0160-0169	AOMORI	AOMORI	774	963	999	1233	1485				
0170-0179	AKITA	AKITA	774	936	1503						
0180-0189	IWATE	MORIOKA	531	684	774	1386					
0190-0199	MIYAGI	SENDAI	891	1089	1260						
0220-0229	YAMAGATA	YAMAGATA	540	774	918	1098	1368				
0230-0239	FUKUSHIMA	KORIYAMA	693	846	1098	1458					
0240-0249	NIIGATA	NIIGATA	792	837	1116	1530	1593				
025	NAGANO	NAGANO	540	621	693	819	864	1098			
0250-0259	GUNMA	MAEBASHI	594	693	954	1134	1242				
0260-0269	TOCHIGI	UTSUNOMIYA	594	693	954	1134	1242	1530			
0270-0279	IBARAKI	MITO	594	693	954	1134	1197	1242			
0280	TOKYO	TOKYO	594	693	810	954	1134	1242	1422		
03, 043, 044, 045	CHIBA	SAITAMA	729	909	1053	1332	1404	1431			
048, 0421-0499	SHIZUOKA	SHIZUOKA	639	882	1404						
051-0536	YAMANASHI	KOFU	693	765	927	954	1134	1242			
0551-0557	SHIZUOKA	NUMAZU	639	882	1404						
0550	AICHI	GIRU	729	792	969	1053	1332	1431			
0558-0559	MIE	TSU	729	828	1053	1332					

G-8

TABLE OF CONTENTS

Control Panel and Remote — Illustrations	G-4
Features	2
How This Manual Is Organized	2
IMPORTANT CAUTIONS	2
Getting Started Right	3
Unpacking	3
Location	3
Set Up	3
1. Set the VOLTAGE SELECTOR Switch	3
2. Put Batteries in the Remote Control	4
3. Connect the AM and FM Antennas	4
4. Connect the Speakers	5
5. Connect the System Connecting Cords and Auxiliary Equipment	5
Common Operations	6
COMPULPLAY	6
Tuning the CA-M30BK On	6
Turning the CA-M30BK Off	6
Adjusting the Brightness of the Display	6
Controlling the Sound	6
Volume Control	6
Sound Effect Modes	6
A.I.S. BASS Effect	7
Listening with Headphones	7
Setting the AM Tuner Interval Spacing	7
One Touch Radio	7
Tuning in a Station	8
Receiving in Stereo or Mono	8
Presetting Stations	8
Listening to a Compact Disc	9
To Prepare Discs	9
To Play a CD	9
To Select the Disc, Track or a Passage within a Track	10
Intro Scan	10
Programming the Playing Order of the Tracks	11
Random Play	11
Program Play	11
A Few Hints to Make Programming Easier	11
Repeating a Selection or the Discs	11
Listening to a Tape	12
One Touch Play	12
Regular Play	12
Fast Left and Fast Right	12
Music Scan	12
Useful Other Features Using the Cassette Deck	13
Listening to Optional Equipment	13
Recording	14
Things to Know before You Start Recording	14
Standard Recording	14
CD to Tape Recording	14
CD Direct Recording	15
Auto Edit Recording	15
Program Edit Recording	16
Tape to Tape Recording (Dubbing)	17
Regular Speed Dubbing	17
High Speed Dubbing	17
How to Set the Clock and Use the Timers	18
Clock Setting	18
Setting the Recording Timer	18
Setting the Daily Timer	19
Setting the Sleep Timer	19
Timer Priority	20
Turning Off the CA-M30BK Automatically	20
Karaoke (Sing Along)	20
Singing Along with Karaoke	20
Recording Karaoke	21
Digital Echo for Professional Sounding Karaoke	21
Recording from the Microphone	21
Microphone Mixing	21
Regular Microphone Recording	21
How to Use the Remote Control	22
Using the 10 Key Pad	22
Care and Maintenance—General Notes	23
Compact Discs	23
Moisture Condensation	23
Cassette Tapes	23
Cassette Deck	23
Troubleshooting	24
Specifications	24
How to Use the Supplied Wire for Better AM Reception	G-5
Checking the Tuner Reception While in Japan	G-6
AM Station Table (East Japan)	G-8
AM Station Table (West Japan)	G-9

English

Features

Here are some of the things that make your CA-M30BK powerful and easy to use.

- To get such great sound from such a compact package, the CA-M30BK has:
 - Pre-programmed live surround effects like DISCO, HALL, STADIUM, as well as SEA effects like BGM, CAR, HI, PHONE. So you don't have to be a sound engineer to get great effects.

The controls and operations have been redesigned to make them very easy to use so you can spend your time listening to music.

- With the One-Touch Operation feature of JVC's COMPULPLAY you can turn on the CA-M30BK and start the radio, the cassette deck, or the CD player with a single touch.
- Four timers, Recording Timer, Daily Timer, Sleep Timer and Auto Power Off are extremely easy to set so you can really use them.
- The Displays are large and clear. They are organized so you can tell at a glance what's happening because functions light up as you use them, and blink to tell you they are ready. In this manual, the display on the amplifier is referred to as the amp display and that on the tuner as the CD/tuner display. The CD/tuner display gives you some important messages like "TIMER OK" and some others.
- Auto Edit figures out how to arrange CD tracks on a tape. When you are recording a tape from a CD, the selections aren't cut off if the tape ends before the selection does.
- Program Edit allows you to arrange CD tracks on a tape in your desired order.

Sing along

- You can use conventional tapes and CDs for Karaoke with the voice canceller system. With an optional microphone, you can replace the lead singer's voice on your favorite songs with your own.
- Digital Echo applied to your voice through the microphone gives you a professional sound.

How This Manual Is Organized

- In this manual we have incorporated some special features:
- A fold-out page to look at while you read the instructions shows the front controls of the CA-M30BK and the Remote Control. Some procedures have the illustrations of which control to use right with them, and for some you will need to look at the fold-out for the illustration.
 - Basic information that is the same for many different functions is grouped in one place, and not repeated in each procedure. For instance, in the section on playing a CD, we do not repeat the information about setting the volume and the sound conditioning, which are talked about in the Common Operations section.
 - Names of buttons and controls are written in all capital letters like this: POWER.
 - When we are talking about the Function, rather than the BUTTON or DISPLAY, then we just capitalize the first letter of the words.
 - The air alerts you to important information or how to solve special problems that may occur when using the CA-M30BK.
 - The column on the left of the page is a special place to make it easier to find just what you want to know about, with little headlines announcing what each part of the page is about. Sometimes illustrations and helpful hints are placed here also.

IMPORTANT CAUTIONS

- Installation of the Unit
 - Select a place which is level, dry and neither too hot nor too cold (between 5°C and 35°C).
 - Leave sufficient distance between the Unit and your TV, or interference may result.
 - Do not use the Unit in a place subject to vibrations.
- Power cord
 - Do not handle the power cord with wet hands!
 - When unplugging from the wall outlet, always pull the plug, not the power cord.
- Malfunctions, etc.
 - There are no user-serviceable parts inside. If anything goes wrong, unplug the power cord and consult your dealer.
 - Do not insert any metallic object into the Unit.

English

English

3. Connect the AM and FM Antennas

FM Antenna Connections

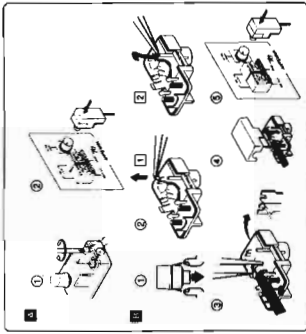

Using the supplied FM feeder antenna

- 1 Attach the FM feeder antenna to the antenna adaptor.
- 2 Connect the antenna adaptor to the FM 75-ohm COAXIAL terminal.

Using FM 75-ohm antenna cable (not supplied)

- 1 Open the claws at both sides of the antenna adaptor and remove the cover.
- 2 Move the conductor wire from terminal [] to [] using tweezers or similar tool. Make this connection only when using coaxial cable.
- 3 See the diagram below "How to strip the 75-ohm coaxial cable" to prepare and insert the coaxial cable into the antenna adaptor.
- 4 Put on the cover.
- 5 Connect the antenna adaptor to the FM 75-ohm COAXIAL terminal.

Note:
Make sure the antenna conductor does not touch any other terminals, connecting cords or the power cord on the system.
If it does, electrical interference may cause poor reception.

Unfold the loops of the supplied FM feeder antenna and extend them as shown. Fasten them up in the position which gives you the best FM reception.

If reception is poor, connect an outside antenna.

Before attaching a 75 ohm coaxial lead (the kind with a round wire going to an outside antenna), disconnect the supplied FM feeder antenna.

How to strip the 75-ohm coaxial cable

- 1 Strip back the outside covering of the 75 ohm coaxial cable to expose the braided metallic mesh.
- 2 Pull the mesh back over the cable as shown.
- 3 Strip the insulation about 10 mm back from the central wire.
- 4 Attach to the supplied antenna adaptor, as shown in the diagram above.

If reception is poor, connect an outside wire antenna. But before connecting one, try to connect the supplied wire first. (See page C-5.)

AM Antenna Connections



Turn the loop until you have the best reception.

Note: Even when connecting an outside AM antenna, keep the indoor AM loop connected.

Snap the tabs on the loop into the slots of the base to assemble the AM loop.

CAUTION: To avoid noise, keep antennas away from metallic parts of the CA-M30BK, connecting cords and the AC power cord.

Getting Started Right

Unpacking

Of course you have already opened your CA-M30BK carton, since you are reading this manual. Although the Unit is quite sturdy, you may want to save the packing to re-pack your CA-M30BK in case you are moving it some distance. Check to be sure you have all of the following things, which are supplied with the CA-M30BK.

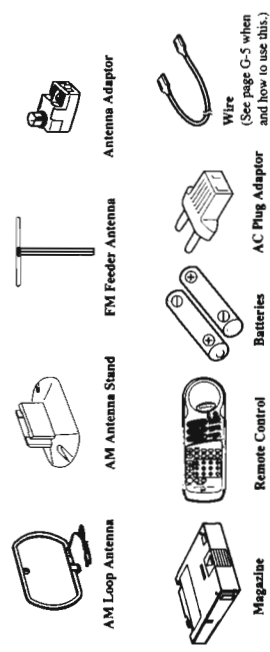

If any are missing, contact your dealer immediately.

Location

You can place the CA-M30BK in many different kinds of locations to suit your needs; just observe the **IMPORTANT CAUTIONS** on page 2; keep away from moisture and heat; leave some space between the Unit and its surroundings, more than 10 cm at the back.

Set Up

You will need to do the following 5 things (pages 3 - 5) to get your CA-M30BK ready to use.

1. Set the VOLTAGE SELECTOR Switch

To avoid damaging the CA-M30BK, set the voltage before plugging in the Unit.

- Set the correct voltage for your area with the VOLTAGE SELECTOR switch on the rear panel of the CA-M30BK. Use a screwdriver to rotate the switch so the number the arrow is pointing at is the same as the voltage where you are plugging in the Unit.

2. Put Batteries in the Remote Control

Match the polarity (+ and -) on the batteries with the + and - markings on the battery compartment.

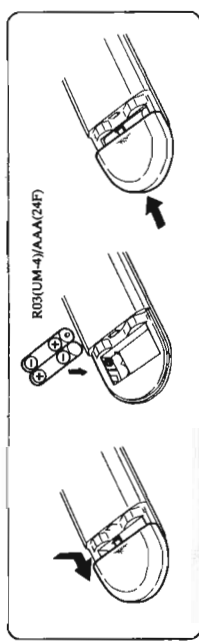

CAUTIONS: Observe Proper Handling of Batteries.

- To avoid battery leakage or explosion:
- Remove batteries when the Remote will not be used for a long time.
- When you need to replace the batteries, replace both batteries at the same time with new ones.
- Don't use an old battery together with a new one.
- Don't use different types of batteries together.

English

Please look at the diagrams and instructions on pages 4 and 5 to do some more things.

Common Operations

Here are the things that apply to all the functions of your CA-M30BK. If something in a later procedure is unclear to you, check back here.

COMPUPLAY

COMPUPLAY is JVC's feature that lets you control the most used functions of the CA-M30BK with a single touch. This One Touch Operation starts playing a CD, turns on the radio, plays a tape, etc. with a single press of the play button for that function. What One Touch Operation does for you is to turn the power on, then start the function you have called for. If the Unit is not ready, such as no CD or tape in place, the Unit still comes on so you can put in a CD or tape. How One Touch Operation works in each case is explained in the section about that function.

Turning the CA-M30BK On

Press **POWER**; the displays come on and the green indicator on **POWER** lights up.
 □ The CA-M30BK comes on ready to do whatever it was doing when the power was last shut off. So if the last thing you were doing was listening to a tape in deck B, you now are ready to listen to a tape again in deck B, or you can change to another source.
 □ If you were listening to the radio last, the radio comes on playing that last station.

Turning the CA-M30BK Off

Press **POWER** again. The green indicator on **POWER** goes out and the displays blank, except for the clock display.
 □ A little power (1.3 watts) is always consumed even though power is turned off (called standby mode).
 □ To switch off the Unit completely, unplug the AC power cord from the AC outlet. When you unplug the AC power cord, the clock will reset to 0:00 right away, while the tuner preset stations will be erased in a few days.

Adjusting the Brightness of the Display

In standby mode (that is, when power is off), you can adjust the brightness of the clock display. Pressing **TUNING/DIMMER** > makes the clock display brighter. Pressing **TUNING/DIMMER** < makes it dimmer.

Controlling the Sound

The same set of buttons and knobs control the sound, no matter which function is producing it. Here we will briefly explain how these controls work, and how you can use them to increase your enjoyment of the music.

Volume Control

Rotate clockwise to increase loudness, counterclockwise to reduce loudness.

CAUTION: Always set the **VOLUME** control to **MIN** before turning on a connected source such as MD, DCC or turntable, or starting any other of the sound sources such as the radio, tape, or CD player. Otherwise, if the **VOLUME** control is turned up, the sudden blast of sound energy can permanently damage your hearing and/or ruin your speakers.

Sound Effect Modes

The CA-M30BK has some preset sound effects that give you control of the way your music sounds, so you can tailor it for your room and for the quality of the source. We can give you some idea of how each one affects the music, but the only way to really tell is to try them yourself. You can use only one effect at a time selecting from the **LIVE SURROUND** or **SEA** effects. Feel free to experiment!

LIVE SURROUND effects

With these effects, the sound coming from only two speakers approaches the quality of sound from four speakers. **DISCO** — increase resonance and bass.

HALL — Add depth and brilliance to the sound, like in a concert hall.

STADIUM — Adds clarity and spreads the sound, like in an outdoor stadium.

To get an effect, press a preset button on the Unit so that the effect name on the amp display lights up. When using the Remote, press **LIVE S**; you can cycle through the effects one after another.

To cancel the effect, press the button again so that the effect name does not light. When using the Remote, press **LIVE S** repeatedly until "LIVE S" goes off on the amp display.

The Magic of COMPUPLAY



Making it sound the way you want it to:

Caution: Too LOUD!



LIVE SURROUND effects: DISCO, HALL, STADIUM

For each speaker connect one end of the speaker wire to the speaker terminals on the rear of the CA-M30BK and the other end to the speaker.

1. Open each terminal.
2. Insert the end of the speaker wire as shown (be sure to remove the insulation at the end of each wire first).
3. Close the terminals to clamp the speaker wires firmly in place.
4. Connect the red (+) and black (-) terminals of the right side speaker to the red (+) and black (-) terminals marked **RIGHT** on the CA-M30BK. Connect the red (+) and black (-) terminals of the left side speaker to the red (+) and black (-) terminals marked **LEFT** on the CA-M30BK.

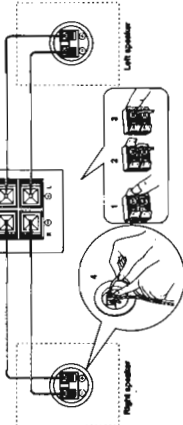

IMPORTANT: Match the polarity of the speaker terminals with the polarity of the terminals on the CA-M30BK, red (+) to red (+) and black (-) to black (-). Check your speakers for correct impedance: 6 ohm speakers only.

5. Connect the System Connecting Cords and Auxiliary Equipment

Turntable
To listen to a record, press **PHONO**.
 • Use MM-type turntables only.

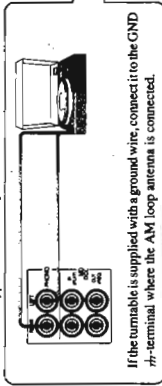

If the turntable is supplied with a ground wire, connect it to the GND terminal where the AM loop antenna is connected.

MD or DCC
To listen to these sources, press **MD/DCC**.

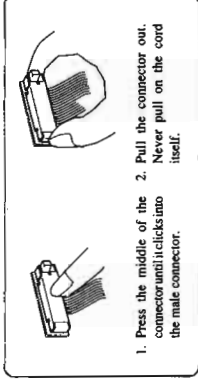

1. Press the middle of the connector until it clicks into the male connector.
2. Pull the connector out; never pull on the cord itself.

CAUTIONS:
 • DO NOT connect optional equipment while the power is on.
 • Make all connections first before plugging the Unit into any AC power outlet.

CAUTION: DO NOT set the voltage selector while the power is on.

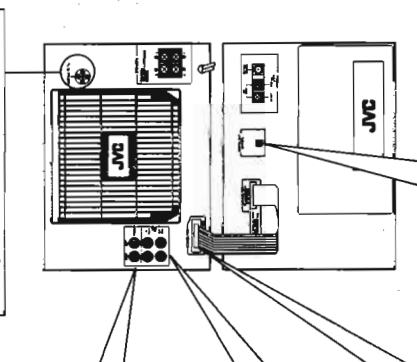

Before connecting an MD or a DCC, remove the protective plug from the terminal.

For digital recording, connect the optical input of MD or DCC. This allows digital recording from CDs played on the Unit to the connected MD or DCC. To do this, refer to the instruction manual supplied with the MD or DCC.

Notes: When recording to the MD through this terminal, DO NOT use automatic marking function of the MD. Otherwise, marking signals cannot be made correctly between the recorded tracks. If you do, you may need to re-mark the signals by using editing function of the MD after recording. It is preferable to use manual marking while recording.

Now you can plug the AC power cord into the wall outlet, and your CA-M30BK is at your command! If the wall outlet does not match the AC plug, use the supplied AC plug adaptor.

SEA effects
BGM
CAR
H. PHONE

English

Preset SEA (Sound Effect Amplifier) effects
Adjustments of frequency range levels have been preset as three SEA effects.
BGM — Used as a background music.
CAR — Used for recording tapes to listen to in a car.
H. PHONE — Used for recording tapes to listen to with headphones.

To get an effect, press SEA MODE (or SEA on the Remote) and you can cycle through the effects one after another.
To cancel the effect, press SEA MODE (or SEA on the Remote) repeatedly until "SEA" goes off on the amp display.

Sound Effect Demonstration
You may be sometimes unable to decide which sound effect to use for the music you are listening to. In this case, you can use a very helpful function — Sound Effect Demonstration.
To get the function, hold down DEMO (the same button as DISCO) during play for a few seconds. The Unit briefly demonstrates six sound modes.
To cancel the function, press DEMO again. Now you can select the best sound mode for the music.

Things to remember about using preset effects:
 Set a preset sound effect before you start recording with CD Direct, Auto Edit or Program Edit, because once recording starts, the preset effect cannot be changed without stopping recording, and often having to start over.
If you need different effects for each selection, use the standard recording features described on page 14, rather than CD Direct, Auto Edit or Program Edit.
 Each of the preset effects changes the sound in a different way by changing which parts of the sound are increased or reduced. To see how each part of the sound will be changed, watch the amp display just as you select an effect when music is playing. For a short while, the display shows the pattern of enhancement for that effect.

AI S. BASS Effect
The richness and fullness of the sound is maintained regardless of how high or low you set the VOLUME control. This effect can be used for both playing and recording, except tape dubbing.
To get the effect, press AI S. BASS so that the indicator on the button lights up.
To cancel the effect, press the button again so that the indicator goes off.



For private listening

Listening with Headphones
A pair of headphones can be connected to the PHONES jack on the front panel. Be sure to turn down the volume before connecting or putting on headphones, as high volume can damage both the headphones and your hearing.

Listening to the Radio

You can listen to both AM and FM. The tuner built into the CA-M30BK can also receive stereo AM broadcasts, which are available in some countries.
 Before listening to the radio:
• Check that both the AM and FM antennas are firmly connected.
• Check the AM tuner interval spacing for your area (see below).

Setting the AM Tuner Interval Spacing
Some countries space AM stations 9 kHz apart, and some countries use 10 kHz spacing. Europe, the U.K., Australia, and some other areas use 9 kHz spacing, while Canada, the United States, and some other Western Hemisphere countries use 10 kHz spacing.
 When shipped, the CA-M30BK is set to 9 kHz spacing.
 To select the 10 kHz interval, be sure power is off, but the Unit is plugged into a wall socket. Press PRESET > so that "10KHz:SP" appears on the CD/tuner display, and then press POWER while that indication still remains.
 To change back to 9 kHz, be sure power is off, but the Unit is plugged into a wall socket. Press PRESET < so that "9KHz:SP" appears on the CD/tuner display, and then press POWER while that indication still remains.

One Touch Radio

Just press AM to turn on the Unit and start playing the most recent AM station tuned in, or press FM to start the most recent FM station tuned in.
 You can switch from any other sound source to the radio by pressing either AM or FM.



Tuning in a Station

Press AM or FM to turn on the radio. The CD/tuner display shows the station frequency tuned to.
Three ways to select a station

1. Press TUNING/DIMMER < or > repeatedly to move from frequency to frequency until you find the one you want.
 2. Hold down TUNING/DIMMER < or > the frequency starts changing on the CD/tuner display. When a station is tuned in, "TUNED" lights up on the display and the frequency stops changing.
 3. (Possible only after presetting stations.) Press once and release PRESET < or > to go to the next preset station, or hold PRESET < or > to cycle through the preset stations; release the button when the preset station you want shows on the CD/tuner display.
- You can also use the Remote to tune in preset channels:
1. Press FM or AM depending on which band you want.
 2. Select the station by entering the preset channel number in the 10 key pad of the Remote.

English

Receiving in Stereo or Mono

The CA-M30BK can receive broadcasts in either stereo or mono, including a new stereo AM available in some countries. When "AUTO" lights up on the CD/tuner display, the CA-M30BK automatically receives broadcasts in the mode they are transmitted. (When a stereo broadcast is received, "STEREO" lights up on the display.) Usually, leaving the CA-M30BK in Auto Mode, with "AUTO" lit, gives you the best reception.
However, due to obstructions or interference, reception of a stereo station may be poor.
To improve reception in cases like this, press STEREO AUTO/MONO on the Remote so that "MONO" on the CD/tuner display lights up. Although you lose the stereo effect, reception may improve.
 You have to set Auto Mode separately for AM and FM.
To restore automatic stereo detection, press STEREO AUTO/MONO so that "AUTO" lights up.



How to preset AM and FM radio stations



Once a station is assigned to a channel number, the station can be quickly tuned either from the Remote using the 10 key pad on the Remote or the CA-M30BK itself using PRESET < or > to call up the channel number.
 You can preset 10 stations each for AM and FM.
 Preset stations may be erased when power is cut off to the Unit for a few days, as when it is unplugged from the AC outlet. If this happens, simply set the stations again.

To preset radio stations

1. Tune in the station you want to set using TUNING/DIMMER < or >.
2. Press MEMORY.
On the CD/tuner display "MEMORY" will blink for 8 seconds.
 During these 8 seconds while "MEMORY" is blinking you can assign a channel number to the station and enter it into the memory.
3. Select a channel number by pressing PRESET < or > until you find the channel number you want.
4. Press MEMORY and the station will be assigned to the channel number showing on the CD/tuner display.
 If a station has been previously stored using the same channel number, it will be erased and the newly selected station will be stored.

Check the tuner reception while in Japan

The CA-M30BK has a special function, which allows you to preset AM and FM stations by simply entering the telephone area code for your residence. After presetting stations using this function, you can check the tuner reception. For more detailed instructions, refer to "Checking the Tuner Reception While in Japan" on pages G-6 to G-9 in the back of this manual.

Listening to a Compact Disc

Here are the basic things you need to know to play a CD and locate the different selections on it. Each selection is called a track, so when we are talking about locating a track, we are also talking about how you find a certain song or performance.

This CD player is called an automatic changer, which can play 6 discs in the supplied magazine and one on the ordinary single tray called PLUS 1 tray.

Basics of Using the CD Player

- The quickest way to start a CD is with the One Touch Operation:
- Press the disc buttons (1 to 6 and P).
 - If no magazine is inserted, the Unit turns on and door opens.
 - Press **D/II** (or **▶** on the Remote) on the CD player.
 - If a CD is already loaded in the inserted magazine or on the PLUS 1 tray, the Unit automatically turns on and starts to play it from track 1.
 - If no CD is loaded, the Unit automatically turns on and the PLUS 1 tray comes out. This is the exactly same as what happens if you press **PLUS 1** (or **▶** on the Remote) instead of **D/II**.

To Prepare Discs

The discs are first loaded into the trays which are then inserted into the magazine. The magazine is then put into the changer. You can also place a disc on the PLUS 1 tray.

To install discs into the magazine

1. To remove the disc tray from the magazine, slide the disc tray out while holding down the tray release button. (See illustration 1 below.)
2. Place a disc on the disc tray with its label side up. (See illustration 2 below.)
3. Lift up the disc tray with the grooves in the magazine and push the disc tray right in.
- If it is necessary to press the tray release button when inserting the disc tray.

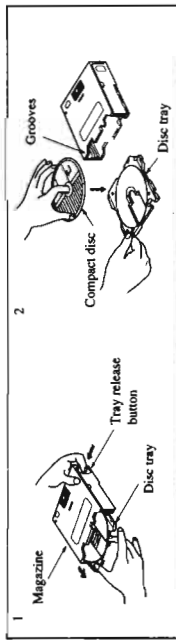

- When inserting or removing a disc tray:
 - Never bend the disc or force it into the magazine. A disc tray inserted skewed may cause a malfunction.
 - The magazine should be held horizontally. (See the illustration to the left.)
 - The openings in the disc trays are for passage of the laser signal. These openings leave a part of the shiny surface of the disc exposed. Do not touch this shiny surface.
 - It is impossible to play a disc if it is upside-down.
- Never place a disc directly in the magazine without using the disc tray.
- If you want to use 8 cm (3 inch) CDs, use an optional magazine designed for these discs — XC-M73

To insert the magazine

1. Press **DOOR OPEN/CLOSE** on the Unit to open the door.
 2. Insert the magazine, with disc loaded, into the changer and push it in gently until it clicks in place.
 - The **▶** mark on the magazine must be facing up.
 3. Press **DOOR OPEN/CLOSE** again to close the door.
- All disc indicator on the door and the CD/turner display light up though there are some empty trays.

To remove the magazine, press MAGAZINE EJECT.

CAUTION: The CD player may be damaged if the magazine is pushed in with too much force.

To load a CD on the PLUS 1 tray

1. Press **PLUS 1**.
- The door opens and the PLUS 1 tray comes out automatically.
2. Put a CD, with its label side up, into the tray.
3. Press **PLUS 1** or **DOOR OPEN/CLOSE** to close the tray.
- If it is necessary to press **PLUS 1** to close the tray, if you press **D/II** to start play, the tray closes automatically.

CAUTION: Place the disc correctly on the circle of the tray.

To remove a CD from the PLUS 1 tray, press **PLUS 1** again.

To Play a CD

1. Prepare discs. (See the previous page.)
 2. Press **D/II** (or **▶** on the Remote).
- The Unit plays the first track on the disc in the PLUS 1. (The current disc number is indicated by the arrow on the display.) If no disc is loaded on the PLUS 1 tray, the Unit automatically skips the empty tray, and finds and plays the discs you have put in the magazine from bottom (Disc No. 1) to top (Disc No. 6). The indicators for these skipped trays go off. The Unit memorizes these empty trays and will skip them next time without searching until the magazine is ejected.

To stop the CD, press **CANCEL** (or **■** on the Remote).

To pause the play, press **D/II** while the CD is playing.

How to find a track

To Select the Disc, Track or a Passage within a Track

By using the Unit

1. If the disc with the track you want is not playing, enter the number of disc you want using the disc buttons (1 to 6 and P) on the rightmost portion of the CD player.

□ Example: for the third disc (from the bottom) in the magazine, press 3.

For the disc on the PLUS 1 tray, press P.

2. Enter the number of the track you want using the track buttons (1 to 10 and +10) on the lowest portion of the CD player.

The selected track starts playing.

□ Example: for track 5, press 5. For track 15, press +10 then 5. For track 20, press +10, then 10.

□ In this step, you can also use **SEARCH/EDIT TIME** (or **▶** or **◀**).

- Each time you press briefly and release **SEARCH/EDIT TIME** (or **▶** or **◀**), the track changes by one.
- Holding down **SEARCH/EDIT TIME** (or **▶** or **◀**) will fast forward or fast reverse the CD so you can quickly find a particular passage in the selection you are listening to.

By using the Remote

1. If the disc with the track you want is not playing, first press **CD DISC**, then enter the number of disc you want using the 10 key pad (1 to 6 and PLUS 1).

□ Example: for the third disc (from the bottom) in the magazine, press 3.

For the disc on the PLUS 1 tray, press PLUS 1.

2. Press **CD TRACK**.

3. Enter the number of the track you want using the 10 key pad.

The selected track starts playing.

□ Example: for track 5, press 5. For track 15, press +10 then 5. For track 20, press +10, then 10.

- You can use **▶** or **◀** to change tracks. However, you cannot fast forward or reverse forward to locate a particular passage using the Remote.

After you have pressed **▶** on the Remote, the 10 key pad on the Remote functions as the disc buttons until you change it.

Intro Scan

You can use two types of intro scan functions (Disc Intro Scan and Track Intro Scan) to search for a desired disc or track.

1. Make sure that the CD is not playing and "CONTINUE" lights up on the CD/turner display.

If not, stop the CD player and press **PLAY MODE** on the Unit until "CONTINUE" lights up on the CD/turner display.

2. Press **INTRO**.

Each time you press the button, the intro scan mode changes and lights up on the CD/turner display in the following sequence:

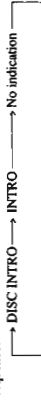

3. Press **D/II** (or **▶** on the Remote).

Disc Intro Scan (when "DISC INTRO" lights up):

Plays the beginning of the first track of each CD for about 15 seconds starting with the disc on the PLUS 1 tray and then disc no. 1 disc through disc no. 6 disc in the magazine.

Track Intro Scan (when only "INTRO" lights up):

Plays the beginning of each track of each CD for about 15 seconds starting with the disc on the PLUS 1 tray and then disc no. 1 disc through disc no. 6 disc in the magazine.

4. Press **SEARCH/EDIT TIME** (or **▶** or **◀**) when the desired track is reached.

Intro scan is canceled and normal playback starts from that track.

□ If you press the following buttons instead of **SEARCH/EDIT TIME** (or **▶** or **◀**), intro scan is also canceled and then:

- **SEARCH/EDIT TIME** (or **▶** or **◀**): Continuous play starts from the next track.
- Disc buttons (1 to 6 and P/PLUS 1): Continuous play starts from the first track of the selected disc.
- Track buttons (1 to 10 and +10): Continuous play starts from the selected track of the current disc.

To stop playing, press **CANCEL** (or **■** on the Remote).

To exit intro scan mode, press **INTRO** so that neither "DISC INTRO" nor "INTRO" lights on the display.



How to use the CD player: from the most basic to advanced

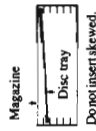

With programming, you can play back tracks in any order

Programming the Playing Order of the Tracks

In addition to the high quality sound which makes the CD such a good way to listen to music, you can change the order in which the tracks play.

Random Play

The tracks will play in no special order when you use this play mode. Before starting a CD, press PLAY MODE repeatedly until "RANDOM" lights up on the CD/tuner display. When all of the tracks have been played, the CD stops.

Press REPEAT before or during random play to instruct the CA-M30BK to continue with a different random track selection after the last selection of the last disc is played.

To stop playing, press CANCEL (or ■ on the Remote). To exit random mode, press PLAY MODE until "RANDOM" is no longer lighted on the CD/tuner display (the Unit must be in stop mode).

Program Play

You can change the order in which the discs and tracks play, and select only the discs and tracks you want from among those loaded in the magazine and the PLUS 1 tray.

You can program from either the Unit buttons or the Remote, or a combination of both. If you use the Remote, be sure to read the section "How to Use the Remote Commander" (page 22).

You can program up to 32 steps in any desired order from among the discs in the player. Since a step can be either a single track or an entire disc with many tracks, the total number of selections which will actually play can be much larger than 32.

How to program

Programming Procedure:

- 1. You can only make or change a program when the player is stopped.
- 1. Press PLAY MODE repeatedly until "PROGRAM" lights up on the CD/tuner display.
- 2. Select a disc with the disc buttons (1 to 6 and P) on the Unit or by pressing CD DISC and using the 10 key pad (1 to 6 and PLUS 1) on the Remote. As soon as a disc is selected, it is memorized and "AL" lights up on the CD/tuner display. If you want all the tracks on that disc to play as part of the program, skip step 3.
- 3. To select individual tracks from the selected disc (its number is indicated by the arrow on the display) enter each track number using either track buttons on the Unit or by pressing CD TRACK and using the 10 key pad on the Remote.
- Example: for track 5, press 5. For track 15, press +10 then 5. For track 20, press +10, then 10.
- 4. Repeat steps 2 - 3 until you have entered all the tracks you want to program.
- 5. Press >M (or ■ on the Remote).

The Unit plays the tracks in the order you have programmed them.

- You can skip to a particular program step by pressing SEARCH/EDIT TIME ►►► during program play
- To play the programmed tracks over and over, press REPEAT on the Remote so that "REPEAT" lights up on the display.

To stop playing, press CANCEL (or ■ on the Remote) once.

To delete the program and exit program mode, press CANCEL on the Unit repeatedly until all the program steps are deleted, and then press PLAY MODE until "CONTINUE" appears on the display.

Programming Hints

A few Hints to Make Programming Easier

To check the program contents (the Unit must be in stop mode)

- Each time you press CALL on the Unit, the program contents are shown on the CD/tuner display in the programmed order.

To change the program contents

- Press CALL until the CD/tuner display shows the program step to correct. Enter the new disc number and/or track number, which will replace the ones originally showing.
- To delete a program step, press CALL until the CD/tuner display shows the program step to delete, then press CANCEL.
- You can use both of these ways to change program steps during programming as well as later.

Repeating a selection on the CDs



Repeating a Selection or the Discs

You can have all the discs, the program or the individual selection currently playing repeat as many times as you like by pressing REPEAT on the Remote.

Each time you press REPEAT, it cycles from function-off, which turns "REPEAT" out on the CD/tuner display, to "REPEAT" which will repeat all the tracks in order or according to the program you have set, and then to "REPEAT 1" which will repeat the currently playing track.

To exit repeat mode, press REPEAT so that neither "REPEAT" or "REPEAT 1" lights on the display.

Listen to a tape: How to use your cassette deck

Listening to a Tape

The cassette deck allows you to play, record and dub audio tapes.

- Most tapes are now recorded with the Dolby NR system, so first check which type of the Dolby NR system has been used on the tape. Only the Dolby B NR is incorporated into the CA-M30BK.
- With Automatic Tape Type Detection, you can listen to type I, II, or IV tapes without changing any settings.
- To record or dub, see Recording on page 14.

COMPUTER PLAY

One Touch Play

By pressing either ► or ◀ on either deck A or B, the Unit will come on, and if a tape is in the deck, it will start to play. If no tape is loaded, the Unit will come on and wait for further instructions.

Regular Play

When the power is already on, you can use this basic procedure:

1. Press EJECT for the deck you want to use.
2. When the cassette carrier opens, put the cassette in, with the exposed part of the tape down toward the base of the CA-M30BK.
- If the cassette carrier does not open, turn the Unit off, then back on again and press EJECT.
3. Close the carrier gently.
4. Press ► to play the front side, or ◀ to play the reverse side. The arrow indicator on the pressed button starts blinking and tape play starts.

To stop playing, press ■.

To remove the tape, press EJECT.

Fast Left and Fast Right

- While the tape is stopped, press ◀◀ and the tape will wind rapidly onto the left side of the cassette without playing.
- While the tape is stopped, press ▶▶ and the tape will wind rapidly onto the right side of the cassette without playing.

Music Scan

To find the beginning of a music track during play, use the Music Scan function. Music Scan searches for blank portions that usually separate tracks, then plays the next song.

- If you use Music Scan on deck A while recording on deck B, recording will stop.

To find the beginning of the current song

Press ◀◀ or ▶▶ during play.

- Make sure that you press ◀◀ or ▶▶ in the opposite direction to tape play. Searching stops automatically at the beginning of the current song, and the current song starts automatically.

To find the beginning of the next song

Press ◀◀ or ▶▶ during play.

- Make sure that you press ◀◀ or ▶▶ in the same direction as tape play. Searching stops automatically at the beginning of the next song, and the next song starts automatically.

The Music Scan works by detecting a 4-second long blank at the beginning of each selection, so it won't work well if your tape has:

- No blank at the beginning of a track.
- Noise (often caused by much use or poor quality dubbing) which fills the blank with noise.
- Long, very soft passages or pauses in a selection. The scan will detect these instead of the 4-second long blanks. If this happens, just go ahead and scan again until you reach the selection you want.

English

English

More useful things to know:

- Reverse Mode
- Continuous Play
- Dolby

Useful Other Features Using the Cassette Deck

- Use Reverse Mode to make the tape automatically reverse at the end of a side and start playing the other side. Press REVERSE MODE to change from Reverse Mode on (the indicator is lit) to Reverse Mode off, or from off, to on.
- Continuous Play: When a tape finishes playing, the Unit always checks to see if a tape is in the other deck. If one is there, it automatically starts playing it while rewinding the first tape. This Continuous Play happens regardless of which deck starts first.
 - With the Reverse Mode on, the other tape will start playing when both sides of the first tape have been played.
 - As long as the REVERSE MODE indicator is lit, the tapes will continue to play in the above sequence.
 - With the Reverse Mode off, the tape will play to the end of the current side, switch to the other deck and start playing a tape there while rewinding the first tape. Then when one side of the tape in the other deck is over, the first deck starts playing the same side again. The tapes will continue to play in the above sequence.
- Press DOLBY B NR to switch Dolby Noise Reduction on (the indicator lights up) or off (the indicator goes off). If a tape is recorded with the Dolby B NR system, playing it back with the Dolby NR on will reduce tape noise and improve the clarity of the sound.

Dolby noise reduction manufactured under license from Dolby Laboratories Licensing Corporation. "DOLBY" and the double-D symbol are trademarks of Dolby Laboratories Licensing Corporation.

Listening to Optional Equipment

By playing the sound from an MD, DCC or turntable through the CA-M30BK, you can gain control over how the music or program sounds. Once the connected equipment is playing through the CA-M30BK, you can apply the sound effects, make recordings, or listen with the headphones.

- First make sure that the connection between optional equipment and the CA-M30BK has been done correctly.

- Set the VOLUME control to MIN.
- Press MD/DCC or PHONO.
- The Unit automatically turns on and "MD/DCC" or "PHONO" lights up on the amp display.
- Start playing the selected equipment.
- The sound from the selected equipment is now played through the CA-M30BK.
- Adjust the VOLUME to a proper listening level.
- Select a desired sound effect mode if you want.

To cancel the setting
Change the source by starting any one of the CA-M30BK's built-in sound sources, such as the radio or CD player.



Two small tabs on the back, one for side A and one for side B, can be removed to prevent accidental erasure or re-recording. To record on a cassette with the tabs removed, you must cover the holes with adhesive tape first. However, when a type II tape is used, only cover part of the hole as shown, since the other part of the hole is used to detect the tape type.

Recording

Recording onto cassette tape from any of the sound sources is easy and the CA-M30BK does most of the work. Just have a tape in deck B, have the source ready, make one or two settings, and you're ready to record. For each source the procedure is a little different and now we'll explain just what to do for each one. If you forget, just come back to the section which has the specific procedures you need. But first, here are a few things to make your recordings better.

Things to Know before You Start Recording

- It may be unlawful to record or playback copyrighted material without the consent of the copyright owner.
- Press DOLBY B NR — the indicator lights up — to reduce tape hiss, except when dubbing tapes since Dolby NR is inactive in dubbing mode regardless of the setting of DOLBY B NR. The dubbed tape automatically contains the same processing as the source tape.
- The recording level, which is the volume at which the new tape is being made, is automatically set correctly, so it is not affected by the VOLUME control on the CA-M30BK. Thus, you can adjust the sound you are actually listening to without changing the recording level.

Copyright



Two small tabs on the back, one for side A and one for side B, can be removed to prevent accidental erasure or re-recording. To record on a cassette with the tabs removed, you must cover the holes with adhesive tape first. However, when a type II tape is used, only cover part of the hole as shown, since the other part of the hole is used to detect the tape type.

Reduce hiss—Dolby NR

When recording, you can use the sound effect modes to condition the music as it is recorded. But when recording using CD Direct, Auto Edit or Program Edit, once recording has started, these settings cannot be changed. When recording from cassette deck A to deck B, the sound effects cannot be used, because the signal doesn't go through the amplifier. This method gives you the highest quality dubbed tapes.

Recording level

Type I, type II and type IV tapes can be used for recording.

CAUTION: If recordings you have made have excessive noise or static, the Unit may be too close to a TV which has been on during the recording. Either turn off the TV or increase the distance between the TV and the CA-M30BK.

Standard recording: Any source to tape

This is the basic method for recording any source. The CA-M30BK also has special ways for recording CD to tape, and tape to tape, which save you time and effort, as well as give you some special effects. However, when you need to add a selection to a tape you have made, or are combining selections from several sources on one tape, use the method we describe here; just substitute the source you want, such as a tape in deck A, or CD, or radio in this procedure. You can also record from the microphone or an auxiliary source with this procedure.

Source to tape: Step by step

- To Record Any Sound Source to Tape
- Follow these steps to record from any sound source onto a tape in deck B.
- Insert a blank or erasable tape into deck B.
 - Press REC PAUSE.
 - The REC PAUSE indicator lights up.
 - Press REVERSE MODE if you want to record on both sides of the tape. The REVERSE MODE indicator lights up.
 - Prepare the source, for example, tuning in a radio station, loading CDs, turning on connected equipment.
 - Press either > to record on the front side, or < to record on the reverse side, on deck B.
- To pause any time during recording process
Press REC PAUSE again. Then press either > or < on deck B to restart recording.
Press ■ on deck B.

CAUTION: During recording, DO NOT change the source or change discs. Otherwise, recording will be interrupted.

Advantages in connecting optional equipment



CD to tape recording: Introduction

There are four ways to record from CD to tape:

- Standard Recording
CD Direct Recording
Auto Edit Recording
Program Edit Recording

CD Direct Recording: Step by step

- 1. Prepare CDs.
2. Set the sound effect mode if you want.
3. Insert a cassette in deck B to record on.
4. Press CD REC START on the cassette deck.

At the end of the tape, the CA-M30BK automatically goes back to the beginning of the last selection and records it, this time gently fading out at the end.

To stop any time during the recording process Press B on deck B.

For CD Direct Recording using more than one disc, use a blank tape. If you use a pre-recorded tape, pre-recorded sound may be unused between newly-recorded tracks.

Auto Edit Recording: Introduction

Using Auto Edit, you can record the CD tracks to fit the tape, so a selection isn't cut off. Auto Edit is one of the best ways to copy all of a CD onto a tape.

Auto Edit Recording: Step by step

- 1. Prepare CDs.
2. Set the sound effect mode if you want.
3. Press EDIT on the CD player repeatedly until "P. EDIT" lights up on the CD/tuner display.
4. Press SEARCH/EDIT TIME on the Remote repeatedly to set the tape length.

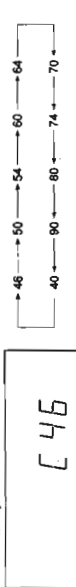

- 5. Press SIDE A/B.
6. Select a disc with the disc buttons (1 to 6 and P).

The display shows which tracks will go on the front side (A) and which on the reverse side (B). Each time you press SIDE A/B, the display switches between A and B.

- 7. To record only on the reverse side (B), show the tracks for the reverse side (B) on the display.
8. Press CD REC START on the cassette deck.

The Unit will automatically rewind the tape to the beginning of the front side, create a 10 second blank, turn on the CD and start recording. (A 10 second blank is also created on the beginning of the reverse side.)

To stop any time during the recording process Press B on deck B or CANCEL on the CD player.

To exit edit mode and delete the program Press PLAY MODE so "A. EDIT" is no longer lighted on the CD/tuner display (the Unit must be in stop mode.)

Program Edit Recording

Using Program Edit, you can record only the CD tracks you want, and fit them onto the tape. Program Edit is one of the best ways to make a tape of only your favourite songs.

- 1. Prepare CDs.
2. Set the sound effect mode if you want.
3. Press EDIT on the CD player repeatedly until "P. EDIT" lights up on the CD/tuner display.
4. Press SEARCH/EDIT TIME on the Remote repeatedly to set the tape length.

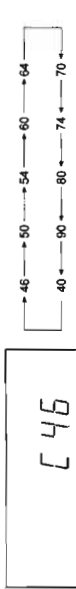

- 5. Press SIDE A/B and select the tracks you want to record on the front side (A).
6. Press SIDE A/B and select the tracks you want to record on the reverse side (B).

The display shows which tracks will go on the front side (A) and which on the reverse side (B). Each time you press SIDE A/B, the display switches between A and B.

- 7. To record only on the reverse side (B), show the tracks for the reverse side (B) on the display.
8. Press CD REC START on the cassette deck.

The Unit will automatically rewind the tape to the beginning of the front side, create a 10 second blank, turn on the CD and start recording. (A 10 second blank is also created on the beginning of the reverse side.)

- 9. Press CD REC START on the cassette deck.
10. Press PLAY MODE so "P. EDIT" is no longer lighted on the CD/tuner display (the Unit must be in stop mode.)

To stop any time during the recording process Press B on deck B or CANCEL on the CD player.

To exit edit mode and delete the program Press PLAY MODE so "P. EDIT" is no longer lighted on the CD/tuner display (the Unit must be in stop mode.)

If you choose wrong tracks during programming, press CANCEL on the CD player. Each time you press the button, the last-chosen track is deleted from the program.

Using the Program Edit, you can program up to 16 tracks for each side of the tape, and cannot program a track the number of which on the disc is greater than 31.

If you want to make some changes in program after starting recording, make sure that the display is showing the tracks for the front side (A) when you restart recording. If not, press SIDE A/B.

How to Set the Clock and Use the Timers

- The timers let you control recording and playing functions automatically. Four types of timers are available:
- Recording Timer**—unattended recording of radio broadcasts. You can set the starting time and recording duration.
 - Daily Timer**—Wake up to music from any source.
 - Sleep Timer**—Fall asleep and have your CA-M30BK turn off automatically after a certain length of time.
 - Auto Power Off**—Automatically turns off the Unit when the CD or tape finishes.

Clock Setting

The timers depend on the clock. If the clock is right, the timers will work like you expect, but if the time is incorrect on the clock then the timers will also be incorrect.

Notice: The clock must be set, or the timers cannot be set!

So, let's set the clock first.

1. Press **CLOCK ADJUST**.
2. Set the hour by pressing **HOUR**. Each time you press **HOUR**, the hour advances by one. Hold the button down, and the hour will advance continuously as long as **HOUR** is held down.
3. Set the minutes by pressing **MINUTE**. Each time you press **MINUTE** the minutes advance by one. Hold the button down, and the minutes advance in ten minute increments as long as **MINUTE** is held down.
4. Press **CLOCK ADJUST** again.

⚠ If there is a power failure, the clock loses its setting, the CD/tuner display shows "0:00," and it must be reset.

Setting the Recording Timer

With the Recording Timer you can make a tape of a radio broadcast automatically, whether or not you are there. For the timer to work correctly, you need to make sure of the following:

- You can set the Recording Timer whether the Unit is on or off.
- The tape you want to record onto must be in deck B.
- The radio station whose program you want to tape must be the last one chosen when the Unit was last turned off.

Follow this procedure to set the Recording Timer

1. Press **REC TIMER** so that "REC" blinks on the CD/tuner display. As long as it is blinking, you can continue with the setting process.
 - If you wait too long, and it stops before you are done, just press **REC TIMER** twice and start over.
2. Set the time you want the radio to come on and the tape in deck B to start recording.
 - Press **HOUR** to set the hour and **MINUTE** to set the minutes.
3. Press **SOURCE/REC TIME** to set the length of time for the recording.
 - Each time you press this button, the duration increases by one minute. If you hold the button down, it will advance in ten minute increments up to 120 minutes, which is the maximum time you can set.
 - At the end of the set length of time the radio and deck B will shut off.
 - If you set no time, but leave the display showing "—:—", the CA-M30BK will not shut off, but keep playing until you shut it off.
4. Press **REC TIMER** again, or wait eight seconds.
 - "TIMER OK" appears and "REC" stops blinking but remains lit on the display.

The Unit will memorize the setting. When the set time comes, the CA-M30BK turns on and records the last station tuned when the Unit was last turned off.

- If you press any button while the Recording Timer is operating, the recording will stop.

Before turning off the Unit

- Check that tape transport direction is correct. This is important especially when Reverse Mode is off.
- Set Reverse Mode on if you want to record on both sides of the tape.
- Select the sound effect mode if you want to record with one of the sound effect modes (DISCO, HALL, STADIUM etc.).
- Set the VOLUME control to MIN so that no sound comes out from speakers when the recording timer switches on the CA-M30BK. This is important especially if you will be out during the recording.

To change the Recording Timer setting

Press **REC TIMER** twice ("REC" reappears) and make any changes you want.

To cancel the Recording Timer setting

Press **REC TIMER** again so that "REC" goes off on the display.

- Four Timers:**
REC TIMER
SLEEP
AUTO POWER OFF

IMPORTANT!

Set your clock!

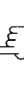

Recording when you're not there

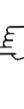

Tape to Tape Recording (Dubbing)

Recording from one tape to another is called dubbing. You can dub at regular speed for the best possible quality, or with a slight loss in sound quality you can dub at high speed. With high speed it takes only about one-half the time to copy a tape.

- To dub both sides of a tape, start from side A for both deck A and deck B, and press **REVERSE MODE** so that the **REVERSE MODE** indicator lights up.
- It is preferable that the type of tape (Normal, CO, or Metal) you record from be the same as the type you record onto.

Regular Speed Dubbing

1. Insert a source cassette you want to copy from into deck A for playback.
2. Insert a blank or erasable cassette you want to copy onto into deck B for recording.
3. Press **REC PAUSE** on deck B.
4. Press **>** (or **<**) on deck B.
 - Recording starts.
 - To advance the leader tape (the beginning of the tape on which you cannot record), start recording (first and wait about 10 seconds before starting deck A).
5. Press **>** (or **<**) on deck A.
 - Deck A starts playing.

To stop any time during the dubbing process

Press **■** on both deck A and deck B.

High Speed Dubbing

Although the quality of the dubbed tape is a little less, high speed dubbing is a very convenient way to record from one tape to another.

1. Insert a source cassette you want to copy from into deck A, and a blank or erasable cassette to be copied onto in deck B.
2. For each deck, select the side (A or B) to start with.
 - To change the side, press **<** or **>** and then quickly press **■** on the same deck.
3. Press **HIGH SPEED DUBBING** on the cassette deck.
 - Both decks start, deck A playing and deck B recording.
 - The sound you hear is strange because it is much faster than usual, and you may not want to listen to it. Turn it down with the **VOLUME** control, or press **FADE MUTING** on the Remote.
 - You can also listen to another source such as the radio or the CD player, just as if you weren't dubbing.

To stop any time during the dubbing process

Press **■** on deck B.

To record selections from several different tapes during high speed dubbing

When you want to take selections from several different tapes and combine them on one tape during high speed dubbing, follow these steps:

1. Press **■** on deck A.
 - This causes deck A to stop, so you can change tapes, and deck B makes a 4-second blank and pauses.
2. Change the tape in deck A.
 - If you don't want to make a 4-second blank, press **REC PAUSE** before pressing **■** on deck A.
3. Press **HIGH SPEED DUBBING** to start deck A playing and deck B recording again.

⚠ **Dolby NR** is inactive in dubbing mode regardless of the setting of **DOLBY B NR**. The dubbed tape automatically contains the same processing as the source tape.

⚠ You cannot dub using the sound effect modes such as **DISCO**, **HALL**, **STADIUM** etc.

⚠ During high speed dubbing, if you listen to a CD with **Auto Power Off** turned on, the whole Unit, including the cassette decks, may turn off when the CD ends. It will interrupt the dubbing.

Tape to tape dubbing: Introduction

Regular speed dubbing: Step by step

High speed dubbing: Step by step



Wake up to music with the Daily Timer



With this timer you can wake up to music from a CD, tape or your favourite radio program. You can set the Daily Timer whether the Unit is on or off.

1. Press DAILY TIMER so that "DAILY" blinks on the CD/tuner display.
2. Set the time you want the Unit to turn on.
3. Press SOURCE/REC TIME to set the hour and MINUTE to set the minute.
4. Each time you press this button, the display shows one of the four possible sources: CD, TAPE, FM or AM. Leave the one you want lit.
 - If you select AM or FM as the source, the last played station is the one which comes on at the set time.
5. Press VOLUME SET repeatedly until your desired volume level is indicated on the CD/tuner display.
6. Each time you press VOLUME SET, the Unit gives you one of the following settings:

Display indication	Volume level	Display indication	Volume level
VOLUME 1		VOLUME 3	
VOLUME 2		VOLUME --	Volume level will be set to the last one used before tuning off.

5. Press DAILY TIMER again, or wait eight seconds. "TIMER OK" appears and "DAILY" stops blinking but remains lit on the display. The Unit will memorize the setting. When the set time comes, the CA-M30BK turns on, plays the selected source at the selected volume level for 60 minutes, and then turns off.
 - When the set time comes, the VOLUME control gradually turns up to and stays at the VOLUME 1 position, then turns up to the VOLUME 2 position.
 - If you press any button while the Daily Timer is operating, the Unit will not turn off automatically after 60 minutes.

Before turning off the Unit

- If the source is tape:
 - Check that the tape transport direction is correct. This is important especially when Reverse Mode is off.
 - Deck B has priority, so if tapes are in both decks, the tape in deck B plays first.
 - Set Reverse Mode on if you want play both sides of the tape.
 - Select the sound effect mode.
- To change the Daily Timer setting Press DAILY TIMER twice ("DAILY" reappears) and make any changes you want.
- To cancel the Daily Timer setting Press DAILY TIMER again so that "DAILY" goes off on the display.

Setting the Sleep Timer

Use the Sleep Timer to turn the Unit off after a certain number of minutes when it is playing. Using this timer, you can fall asleep to music.

- You can only set the Sleep Timer when the Unit is on and a source is playing.

Follow this procedure to set the Sleep Timer

- With the Unit on and a source playing, press SLEEP. "SLEEP" starts blinking on the CD/tuner display.
- Each time you press SLEEP while "SLEEP" is blinking, it changes the number of minutes shown on the display in this sequence:



When the number of minutes you want shows on the display, just wait eight seconds until "TIMER OK" appears and "SLEEP" stops blinking, but remains lit. The Unit will now turn off after the number of minutes you set.

To change the Sleep Timer setting

Press SLEEP until the number of minutes you want appears on the display.

To cancel the Sleep Timer setting

Press SLEEP until "SLEEP" goes off on the display. Turning off the Unit also cancels the Sleep Timer.

Timer Priority

Since each timer can be set independently, you may have wondered what happens if the settings overlap: for instance, suppose you set the Recording Timer to record a broadcast from 1 am to 1:30 am, and then you set the Sleep Timer at midnight to run until 2 am. Will you still get your radio program recorded? Here are the priorities for each timer:

- The Recording Timer always has priority. This means that:
 - If another timer is set to come on during a time the Recording Timer is operating, the other timer just won't come on at all, so you will always get the entire program on tape.
 - If the Recording Timer is set to come on while the Sleep Timer is operating, the Sleep Timer will shut off several seconds before the Recording Timer is set to turn on, and the Recording Timer will then take over.

CAUTION: DO NOT set the Recording Timer to turn on while the Daily Timer is operating. Otherwise, you will not get the recording done. When the set time for the Recording Timer comes, the Daily Timer shuts off, but recording will not start even though the source is switched to the tuner, and the VOLUME control is set to the minimum.

- The Sleep Timer has priority over the Daily Timer. This is important because if you set the Sleep Timer to start before and then end after the Daily Timer would start, the Daily Timer doesn't come on. So if you want your alarm to go off as scheduled, be sure the Sleep Timer shuts off before the Daily Timer is to turn on the Unit.

Turning Off the CA-M30BK Automatically

When playing either a tape or a CD, Auto Power Off will shut the Unit off when the tape or CD comes to the end. Although Auto Power Off is very useful for shutting off the Unit at night, you can also use it if you think you might forget to turn the Unit off when leaving the house or your room at other times of day.

To use Auto Power Off:

Press AUTO POWER OFF so that "AUTO POWER OFF" lights up on the amp display.

To cancel Auto Power Off:

Press AUTO POWER OFF again so that "AUTO POWER OFF" disappears on the display.

Important information on using Auto Power Off

- If you press AUTO POWER OFF ("AUTO POWER OFF" lights up on the amp display) while the CD is playing in repeat mode ("REPEAT" or "REPEAT 1" lights on the CD/tuner display), repeat mode will be canceled and Auto Power Off will be able to work.
- If you press REPEAT to set the CD player in repeat mode while Auto Power Off is on ("AUTO POWER OFF" lights on the amp display), Auto Power Off will be canceled even though "AUTO POWER OFF" remains lit on the amp display.
- If you press AUTO POWER OFF while tape is playing:
 - If Reverse Mode is off (the REVERSE MODE indicator is not lit), the Unit turns off when the currently playing side finishes.
 - If Reverse Mode is on (the REVERSE MODE indicator lights up), the Unit plays the side currently playing, reverses and plays the other side, then shuts off.

Karaoke (Sing Along)

The KARAOKE voice canceller button lets you use regular tapes, CDs or records as sources of sing-along music. When you press KARAOKE, the lead vocal is reduced, and you can replace it by singing into the microphone as the music plays.

Singing Along with Karaoke

1. Turn the MIC LEVEL control to MIN.
2. Attach the microphone (not supplied) by plugging it into the MIC jack on the front panel.
3. Start the source—CD, tape, or connected equipment.
4. Press KARAOKE so that "KARAOKE" lights up on the amp display.
5. Adjust the VOLUME control and the MIC LEVEL control, as you sing into the microphone.

What is Karaoke?

Sing along procedure

Recording a Karaoke session

- Here's the procedure for recording Karaoke:
1. Insert a blank or erasable cassette you want to record onto in deck B.
 2. Press REC PAUSE so that the REC PAUSE indicator lights up.
 3. Follow the above procedure "Singing Along with Karaoke."
 4. Press > (or <) on deck B, and deck B will start recording the source together with your voice in place of the lead vocal.



Digital Echo for Professional Sounding Karaoke

Adjust the DIGITAL ECHO control to change the amount of echo in your voice as it goes through the CA-M30BK. This effect can be used for recording as well.

Important Information on Karaoke

- Because the radio signal is not as reliable as signals coming from a tape or CD, you may not always get satisfactory results using the radio as a source for Karaoke.
- Some tapes and CDs are better sources for Karaoke than others.
 - Mono sources are not suitable for Karaoke.
 - On sources with duets, strong echoes, a chorus, or with only a few instruments, the singer's voice may not be completely reduced.
 - Poorly dubbed tapes may not work well for Karaoke.

Recording from the Microphone

You can use the microphone for two kinds of recording:

- Microphone mixing—Sound going into the microphone is mixed with sound sent to the tape in deck B from some other source, such as the CD, or radio.
- Regular recording—Only sound picked up by the microphone is recorded.

Two ways of recording with the microphone

Microphone Mixing

1. Insert a blank or erasable cassette you want to record onto in deck B.
 2. Connect the microphone to the MIC jack.
 3. Press REC PAUSE so that the REC PAUSE indicator lights up.
 4. Start the source—CD, tuner, or connected equipment—and set the VOLUME control.
 5. Adjust the microphone volume with the MIC LEVEL control.
 6. Press > (or <) on deck B, and speak or sing into the microphone.
- Both sound from the microphone and from the playing source is recorded.

Regular Microphone Recording

1. Insert a blank or erasable cassette you want to record onto in deck B.
 2. Connect the microphone to the MIC jack.
 3. Press REC PAUSE so that the REC PAUSE indicator lights up.
 4. Press >M on the CD player and then press CANCEL to stop the CD player.
 5. Adjust the volume of the microphone with the MIC LEVEL control.
 6. Press > (or <) on deck B.
- Whatever sounds the microphone picks up are recorded.

IMPORTANT!

To prevent howling and squealing when using the microphone, adjust the MIC LEVEL control and the VOLUME control, and try not to point the microphone at the speakers. When you will not be using the microphone, keep the MIC LEVEL control set to MIN, and disconnect the microphone.

How to Use the Remote Control

The Remote Control makes it easy to use many of the functions of the CA-M30BK from a distance of up to 6 m away. You do need to point the remote sensor at the CA-M30BK from panel.

- Most of the buttons on the Remote Control do just what the ones on the CA-M30BK do.
- A few functions are available only by using the Remote Control, and those are described below.

Using the 10 Key Pad

The 10 key pad is used to specify a CD, a CD track or the number you have assigned to a preset radio station. To enter a number using the 10 key pad, follow these steps:

- Before using the 10 key pad, check to see whether the 10 key pad is functioning to operate the CD player or tuner. This is depends on which button on the Remote you have pressed before using the 10 key pad. For example, if you press AM or FM before the 10 key pad, it can select a preset station. If you press CD/DISC or CD TRACK, it can select a CD or a CD track.
- For numbers between 1 and 10, just press the button with the number you want.
- For numbers from 11 to 20, first press the +10 key, then the one's digit of the number you want — to get 15, first press +10, then 5. For 20 press +10 and 0.
- For numbers from 21 to 30, press the +10 key twice; then press the one's digit — to get 25, press +10 +10 and 5. For 30, press +10 +10 and 0.
- For numbers from 31 to 32, follow the same procedure, only press the +10 key three times, then the one's digit — to get 32, press +10 +10 +10 and 2.

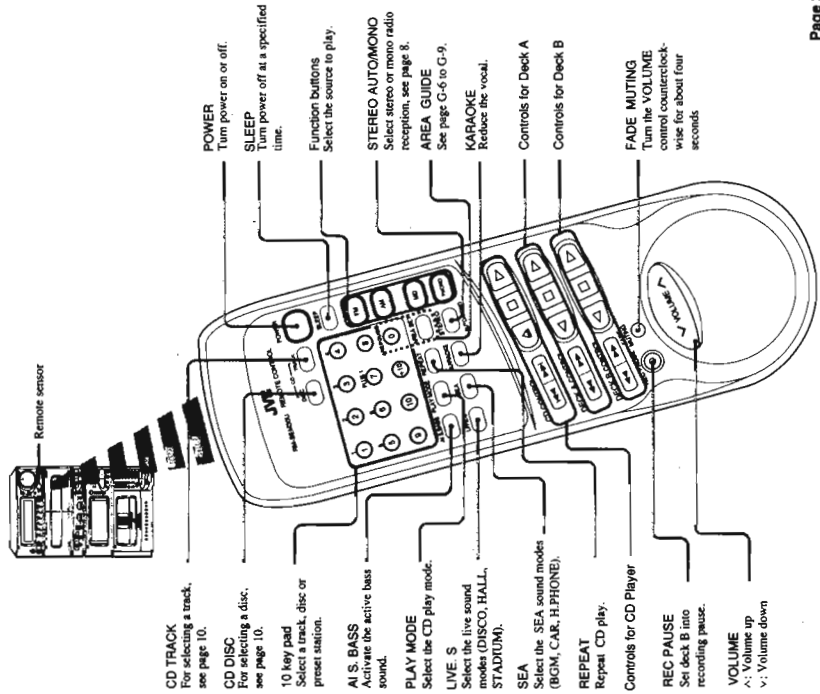

Troubleshooting

- If you are having a problem with your CA-M30BK, check this list for a possible solution before calling for service.
- If you cannot solve the problem from the hints given here, or the Unit has been physically damaged, call a qualified person, such as your dealer, for service.

Symptom	Possible Cause	ACTION
No sound is heard.	Connections are incorrect, or loose.	Check all connections and make corrections. (See pages 4 and 5.)
Impossible to record.	Cassette record protect tabs are removed.	Cover holes on back edge of cassette with tape.
Hard to listen to broadcasts because of noise.	The antenna is disconnected. The AM loop antenna is too close to the Unit. The FM wire antenna is not properly extended and positioned.	Re-connect the antenna securely. Change the position and direction of the AM loop antenna. Extend FM wire antenna to the best reception position.
The CD sound is discontinuous.	The CD is scratched or dirty.	Clean or replace the CD.
Unable to operate the Remote.	The path between the Remote and the sensor on the Unit is blocked. The batteries are discharged.	Remove the obstruction. Replace the batteries.
The CD tray cannot be operated.	The main AC power cord is not plugged in.	Plug in the AC power plug.
The CD does not play.	The CD is upside down.	Put the CD in with the label side up.
Operations are disabled.	The built-in microprocessor may malfunction due to external electrical interference.	Unplug the Unit; then plug it back in.
The cassette carrier cannot be opened.	The Unit was turned off because the timer was operated while the tape was running.	Turn on the Unit.

Care and Maintenance—General Notes

Cassette Tapes

Compact Discs

- Handle your compact discs, cassette tapes, and cassette deck carefully, and they will last a long time.
- Remove the CD from the case by holding it at the edges while pressing the center hole lightly.
- Do not touch the shiny surface of the CD, or bend the CD.
- Put the CD back in its case after use to prevent warping.
- Be careful not to scratch the surface of the CD when placing it back in the case.
- Avoid exposure to direct sunlight, temperature extremes, and moisture.
- A dirty CD may not play correctly. If a CD does become dirty, wipe it with a soft cloth in a straight line from center to edge.

- If the tape is loose in its cassette, take up the slack by inserting a pencil in one of the reels and rotating.
- If the tape is loose, it may get stretched, cut, or caught in the cassette.
- Do not store the tape:
 - In dusty places
 - In direct sunlight or heat
 - In moist areas
 - On a TV or speaker
 - Near a magnet

CAUTION: Do not use any solvent (for example, conventional record cleaner, spray, thinner, benzine, etc.) to clean a CD.

Moisture Condensation

- Moisture may condense on the lens inside the Unit in the following cases:
 - After starting the heating in the room.
 - In a damp room.
 - If the unit is brought directly from a cold to a warm place.
- Should this occur, the Unit may malfunction. In this case, leave the unit turned on for a few hours until the moisture evaporates; unplug the AC power cord, and then plug it in again.

- In general, you will have the best performance by keeping your tapes, CDs, and the mechanism clean.
 - Store tapes and CDs in their cases, and keep them in cabinets or on shelves.
 - Keep the cassette deck tape carriers and the CD tray closed when not in use.

Cassette Deck

- If the heads, capstans, and pinch-rollers of the cassette deck become dirty, the following will occur:
 - Impaired sound quality
 - Discontinuous sound
 - Fading
 - Incomplete erasure
 - Difficulty recording
- Clean the heads, capstans, and pinch-rollers using a cotton swab moistened with alcohol.

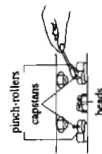

- If the heads become magnetized, the Unit will produce noise or lose high frequencies.
- To demagnetize the heads, turn off the Unit, and use a head demagnetizer (available at electronics and record shops).

Specifications

Amplifier/Cassette Deck Section

Amplifier		
Output Power (IEC 268-3)	50 watts per channel, min. RMS, both channels driven into 6 ohms at 1 kHz with no more than 5% total harmonic distortion.	
Input Sensitivity/Impedance (1 kHz)	300 mV/47 kohms	Compact Disc Player
MD/DCC IN	3 mV/47 kohms	Dynamic Range
PHONO	2 mV/10 kohms	Wow and Flutter
MIC		Dimensions
		Weight
Output Load/Impedance	150 mV/2.7 kohms	Speaker
MD/DCC OUT	660 ohm	Speaker system
DIGITAL OUT (OPTICAL)	-18 dBm	Dimensions
Wavelength		Weight
Output level	6 ohms	General
Speaker terminals		Power Requirements
		Power Consumption
Cassette Deck		Supplied Accessories
Frequency response	30—17,000 Hz	FM wire antenna (1)
Meat:	30—16,000 Hz	AM loop antenna (1)
Co-0:	30—15,000 Hz	AM antenna stand (1)
Normal:	0.09% (WRMS)	Wire (1)
Wow and Flutter		Antenna adaptor (1)
		AC plug adaptor (1)
Dimensions	245 x 183 x 340 mm (W/H/D) (9 7/8 x 7 1/4 x 13 7/16 inches)	Magazine (1)
Weight	5.6 kg (12.3 lbs)	Remote control (1)
Tuner/CD Player Section		Batteries R03(LIN-4)/AAA(24F) (2)
Tuner		The following items are included in the speaker carton
FM Tuner		Speaker cords (2)
Tuning Range	76—108.0 MHz	Design and specifications subject to change without notice.
AM Tuner		
Tuning Range	MW: 522—1629 kHz (at 9 kHz channel space) SW: 530—1600 kHz (at 10 kHz channel space)	

DX-M30BK

– Contents –

Description of ICs	20
Internal Connection of the Display	25
Disassembly Procedures	26
Adjustment Procedures	30
Schematic Diagrams	33
Printed Circuit Boards	37
Block Diagrams	39

Description of ICs

■ MN171202JHX(IC901) : System controller

Terminal Layout

VDD	1	64	OSC1
S1	2	63	OSC2
S2	3	62	VSS
S3	4	61	X2
S4	5	60	X1
S5	6	59	KI3
S6	7	58	KI2
S7	8	57	KI1
S8	9	56	KI0
S9	10	55	ACO
S10	11	54	SPK
S11	12	53	TUNER RESET
S12	13	52	STANDBY IND
S13	14	51	DECK RESET
S14	15	50	SOURCE MUTE
S15	16	49	DECK INH
S16	17	48	DCS OUT
VPP	18	47	DCS IN
VOL UP	19	46	INH
VOL DOWN	20	45	REMOCON IN
1G	21	44	PROTECTOR IN
2G	22	43	RESET
3G	23	42	DTAO
4G	24	41	DTAI
5G	25	40	DSTB
6G/KO0	26	39	CSB
7G/KO1	27	38	S.OUT
8G/KO2	28	37	S.STB
9G	29	36	SCK
10G	30	35	
AI S. BASS IND	31	34	MODE1
VOL IND	32	33	MODE2

Key Matrix

	KEY IN 0 (Pin56)	KEY IN 1 (Pin57)	KEY IN 2 (Pin58)	KEY IN 3 (Pin59)
KEY OUT 0 (Pin26)	POWER	MD/DCC	PHONO	AI S. BASS
KEY OUT 1 (Pin27)	SEA MODE	KARAOKE	A. P. OFF	—
KEY OUT 2 (Pin28)	DISCO	HALL	STADIUM	—

Terminal Description

Pin NO.	Symbol	I/O	Function	Pin NO.	Symbol	I/O	Function
1	VDD	--	Power supply	33	MODE2	I	Chip select
2	S1	O	FL segment control	34	MODE1	I	Chip select
3	S2	O	FL segment control	35	--	--	Not used
4	S3	O	FL segment control	36	SCK	O	Clock for data transfer to selectors
5	S4	O	FL segment control	37	S.STB	O	Strobe signal for selectors
6	S5	O	FL segment control	38	S.OUT	O	Data for input selector
7	S6	O	FL segment control	39	CSB	O	Chip select signal
8	S7	O	FL segment control	40	DSTB	O	Strobe signal for equalizer filter
9	S8	O	FL segment control	41	DTAI	O	Data for equalizer filter
10	S9	O	FL segment control	42	DTAO	I	Data from equalizer filter
11	S10	O	FL segment control	43	RESET	I	System reset input
12	S11	O	FL segment control	44	PRT. IN	I	Protector detection
13	S12	O	FL segment control	45	RM. IN	I	Remote control signal input
14	S13	O	FL segment control	46	INH	I	Inhibit signal input
15	S14	O	FL segment control	47	DCS IN	I	Compulink signal input
16	S15	O	FL segment control	48	DCS OUT	O	Compulink signal output
17	S16	O	FL segment control	49	DECK INH	O	Inhibit signal to deck controller
18	VPP	--	Power supply for FL display	50	S.MUTE	O	Source muting
19	VOL UP	O	Main volume control	51	DECK RST	O	Reset signal to deck controller
20	VOL DOWN	O	Main volume control	52	STBY. IND	O	Indication signal
21	1G	O	FL grid control	53	TU.RESET	O	Reset signal to tuner
22	2G	O	FL grid control	54	SPK	O	Speaker relay control signal
23	3G	O	FL grid control	55	ACO	O	Power supply control signal
24	4G	O	FL grid control	56	KI0	I	Key matrix input
25	5G	O	FL grid control	57	KI1	I	Key matrix input
26	6G/KO0	O	FL grid control (Key matrix out)	58	KI2	I	Key matrix input
27	7G/KO1	O	FL grid control (Key matrix out)	59	KI3	I	Key matrix input
28	8G/KO2	O	FL grid control (Key matrix out)	60	X1	--	Not used
29	9G	O	FL grid control	61	X2	--	Not used
30	10G	O	FL grid control	62	VSS	--	GND
31	AI S. B. IND.	O	Indication control	63	OSC2	--	Oscillation terminal
32	VOL IND.	O	Indication control	64	OSC1	--	Oscillation terminal

■ HD4074008SD93 (IC491) : Deck controller

Terminal Layout

NR LED	1	64	A.FWD LED
NR LED (C)	2	63	A.REV LED
A.SPEED UP	3	62	B.FWD LED
B.SPEED UP	4	61	B.REV LED
MUSIC IN	5	60	REC LED
B.FWD REEL MOTOR	6	59	REV MODE
B.REV REEL MOTOR	7	58	BIAS
B.REV CAM MOTOR	8	57	NR OFF
B.FWD CAM MOTOR	9	56	REC MUTE
A.CAM SW 2	10	55	DCS IN
A.CAM SW 1	11	54	DCS OUT
A.CAM SW 0	12	53	GND
A.PULSE IN	13	52	OSC IN
B.CAM SW 2	14	51	OSC OUT
B.CAM SW 1	15	50	TO VCC
B.CAM SW 0	16	49	RESET IN
B.PULSE IN	17	48	KEY&SW IN 4
POWER OFF IN	18	47	KEY&SW IN 3
GND	19	46	KEY&SW IN 2
A.FWD REEL MOTOR	20	45	KEY&SW IN 1
A.REV REEL MOTOR	21	44	KEY OUT 4
A.REV CAM MOTOR	22	43	KEY OUT 3
A.FWD CAM MOTOR	23	42	KEY OUT 2
NR REC	24	41	KEY OUT 1
A MUTE	25	40	SW OUT 2
B MUTE	26	39	SW OUT 1
PLAY MUTE	27	38	HI-SPEED DUBBING
CAPSTAN MOTOR ON	28	37	HS CrO ₂
REC	29	36	HS METAL
FADE CONTROL	30	35	HS NORMAL
BEQ	31	34	CrO ₂
+5V	32	33	METAL

Key matrix

	KEY IN 1 (Pin45)	KEY IN 2 (Pin46)	KEY IN 3 (Pin47)	KEY IN 4 (Pin48)
SW OUT 1 (Pin39)	—	B CrO ₂	METAL	—
SW OUT 2 (Pin40)	BPACK	REV REC	FWD REC	APACK
KEY OUT 1 (Pin41)	A◀	A◀◀	A▶▶	A▶
KEY OUT 2 (Pin42)	B◀	B◀◀	B▶▶	B▶
KEY OUT 3 (Pin43)	A■	B■	REC PAUSE	—
KEY OUT 4 (Pin44)	A▶▶B	DOLBY	REV. MODE	CD REC

Terminal Description

Pin NO.	Symbol	I/O	Function	Pin NO.	Symbol	I/O	Function
1	NR LED	O	Indication control for NR	33	METAL	O	Metal tape , normal speed record
2	NR LED(C)	O	Not used	34	CrO ₂	O	CrO ₂ tape , normal speed record
3	A S UP	O	Reel speed up control (Deck A)	35	HS NORM	O	Normal tape , high speed record
4	B S UP	O	Reel speed up control (Deck B)	36	HS METAL	O	Metal tape , high speed record
5	MUSIC IN	I	Music scan signal input	37	HS CrO ₂	O	CrO ₂ tape , high speed record
6	B F R M	O	Reel control signal for forward (Deck B)	38	HI DUB	O	It is "L" when high speed dubbing
7	B R R M	O	Reel control signal for reverse (Deck B)	39	SW O1	O	Keymatrix output for leaf switches
8	B R C M	O	Cam control signal for reverse (Deck B)	40	SW O2	O	Keymatrix output for leaf switches
9	B F C M	O	Cam control signal for forward (Deck B)	41	KEY O1	O	Key matrix output
10	A C SW2	I	Cam data input	42	KEY O2	O	Key matrix output
11	A C SW1	I	Cam data input	43	KEY O3	O	Key matrix output
12	A C SW0	I	Cam data input	44	KEY O4	O	Key matrix output
13	A.PULS IN	I	Reel pulse input from deck A	45	KEY/SW I1	I	Key matrix input
14	B C SW2	I	Cam data input	46	KEY/SW I2	I	Key matrix input
15	B C SW1	I	Cam data input	47	KEY/SW I3	I	Key matrix input
16	B C SW0	I	Cam data input	48	KEY/SW I4	I	Key matrix input
17	B.PULSE IN	I	Reel pulse input from deck B	49	RESET	I	Reset input
18	P.CONT	I	Inhibit input from system controller	50	TO VCC	--	Connected to VCC
19	GND	--	GND	51	OSC	--	Oscillation terminal
20	A F R M	O	Reel control signal for forward (Deck A)	52	OSC	--	Oscillation terminal
21	A R R M	O	Reel control signal for reverse (Deck A)	53	GND	--	Gnd
22	A R C M	O	Cam control signal for reverse (Deck A)	54	DCS OUT	O	Compulink output
23	A F C M	O	Cam control signal for forward (Deck A)	55	DCS IN	I	Compulink input
24	NR REC	O	It is "H" when recording with NR on	56	REC MUTE	O	Recording mute control
25	A MUTE	O	It is "H" when deck A is not playing	57	NR OFF	O	NR on/off control
26	B MUTE	O	It is "H" when deck B is not playing	58	BIAS	O	Bias on/off control
27	PLAY MU	O	Deck mute	59	REV MODE	O	Indication control for reverse mode
28	CAP CONT	O	Capstan on/off control	60	REC LED	O	Indication control for record
29	REC	O	It is "H" when recording	61	BREV LED	O	Indication control for reverse playback
30	FADE CON	O	It is "H" when recording with fade	62	BFWD LED	O	Indication control for forward playback
31	BEQ	O	Bias /Playback EQ control	63	AREV LED	O	Indication control for reverse playback
32	+5V	--	Power supply	64	AFWD LED	O	Indication control for forward playback

■ BA7725S (IC990) : Echo circuit

Internal Block Diagram

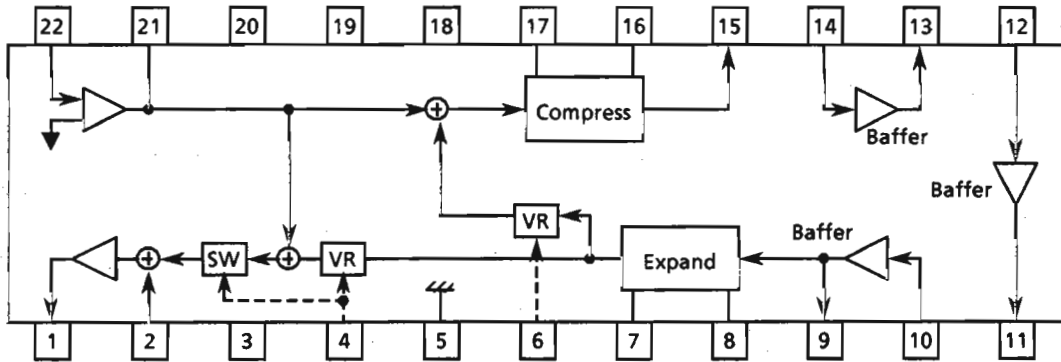

Terminal Description

Pin No.	Symbol	Function
1	LINE OUT	Line output
2	LINE IN	Line input
3	NC	Not used
4	ECHO LEV CTRL	Determines echo level. The echo circuit is off when 1 volt is added. The echo level varies according to the voltage from 2 volts to 9 volts.
5	GND	Analog GND
6	LOOP GAIN CTRL	Loop gain control terminal. The gain varies according to the voltage from 2 volts to 9 volts.
7	EXP DET	Detection terminal for expand circuit
8	EXP DET CT	Determines the attack and recovery time of expand circuit
9	EXP BF OUT	Buffer output (Expand circuit side)
10	EXP BF IN	Buffer input (Expand circuit side)
11	DLY BF OUT	Delay buffer output
12	DLY BF IN	Delay buffer input
13	CMP BF OUT	Buffer output (Compress circuit side)
14	CMP BF IN	Buffer input (Compress circuit side)
15	CMP OUT	Compress circuit output
16	CMP DET CT	Determines the attack and recovery time of compress circuit
17	CMP DET	Detection terminal for compress circuit
18	RIPPLE FILTER	A capacitor is connected for ripple elimination filter
19	VCC	Power supply
20	NC	Not used
21	MICAMP OUT	Mic amp output
22	MICAMP IN	Mic amp input

■ LB1639-CV (IC508) : Motor driver

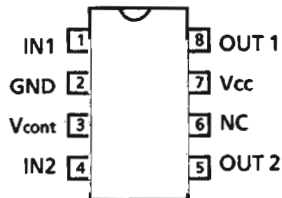

IN1(Pin1)	IN2(Pin4)	OUT1(Pin8)	OUT2(Pin5)	MOTOR
H	L	H	L	Counterclockwise
L	H	L	H	Clockwise
H	H	OFF	OFF	Waiting
L	L	OFF	OFF	Waiting

■ LB1641 (IC451~454) : DC Motor driver

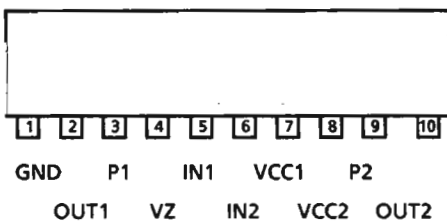

Function

Input		Output		Mode
IN1	IN2	OUT1	OUT2	
0	0	0	0	Brake
1	0	1	0	Forward
0	1	0	1	Reverse
1	1	0	0	Brake

∞: Hig impedance

■ BU9251S(IC999) : Delay circuit

Internal Block Diagram

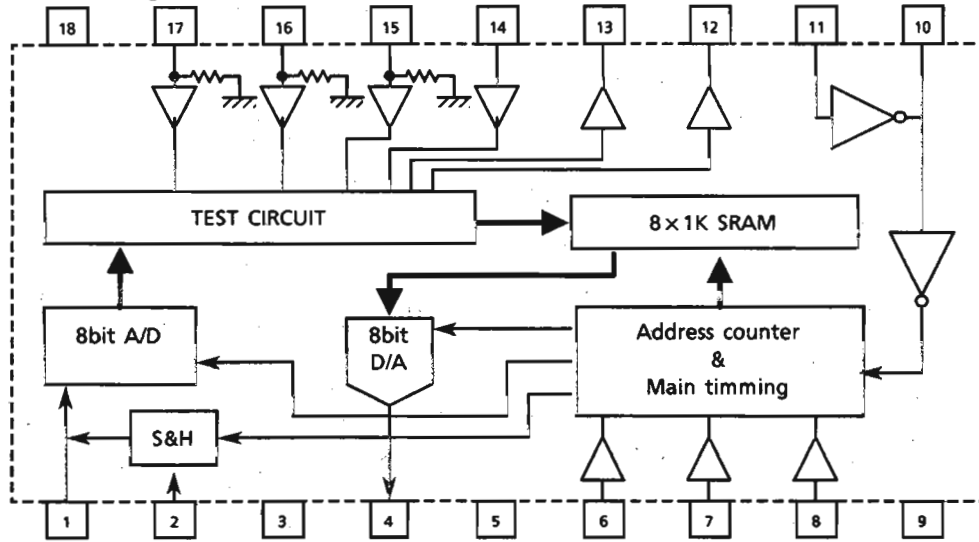

Terminal description

Pin No	Symbol	Function	Pin No	Symbol	Function
1	S&H	A capacitor is connected for sample&hold	10	OSC0	Oscillation terminal
2	AIN	Analog input	11	OSC1	Oscillation terminal
3	GND	GND	12	TDO1	Test terminal
4	AOUT	Analog output	13	TDO0	Test terminal
5	VDD	Power supply	14	TDIN	Test terminal
6	DCNT0	Delay time control	15	TST2	Test mode terminal
7	DCNT1	Delay time control	16	TST1	Test mode terminal
8	DCNT2	Delay time control	17	TST0	Test mode terminal
9	GND	GND	18	VCC	Power supply

■ BA8221N (IC353) : ALC

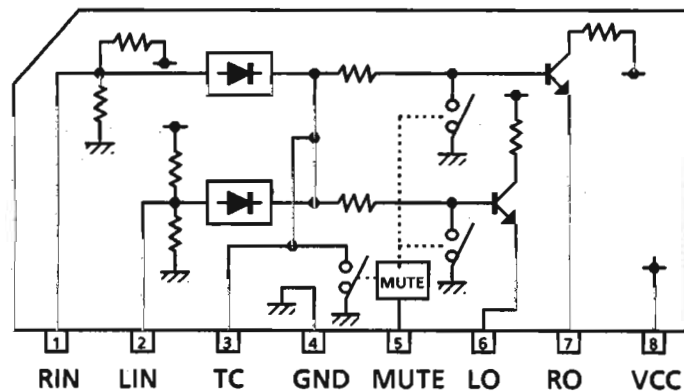

■ XR1099(IC701) : 7-channel graphic equalizer filter with A/D converter

Internal Block Diagram

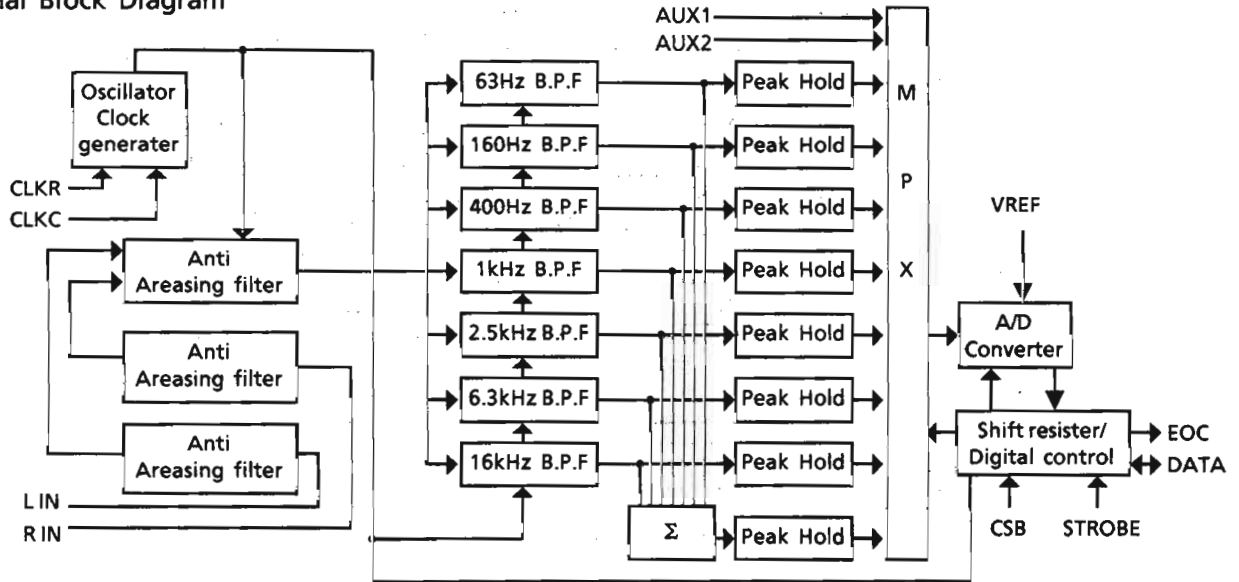

Terminal Layout

CSB	1	16	VDD
STB	2	15	CLKR
DATAI	3	14	CLKC
DATAO	4	13	GND
EOC	5	12	LIN
VREF	6	11	RIN
AUX2	7	10	VSS
AUX1	8	9	TEST

Terminal Description

Pin No	Symbol	I/O	Function	Pin No	Symbol	I/O	Function
1	CSB	I	Chip select	8	TEST	I	TEST Terminal
2	STB	I	Strobe signal	19	VSS	-	-5V
3	DATAI	I	Data output	10	RIN	I	Sound signal input
3	DATAO	O	Data input	10	LIN	I	Non connection
4	EOC	-	Not used	11	GND	-	GND
5	VREF	I	A/D converter reference voltag	12	CLKC	-	A capacitor is connected
6	AUX2	I	Non connection	13	CLKR	-	A resistor is connected
7	AUX1	I	Non connection	14	VDD	-	+5V

■ HA12136A (IC352) : NR amplifier

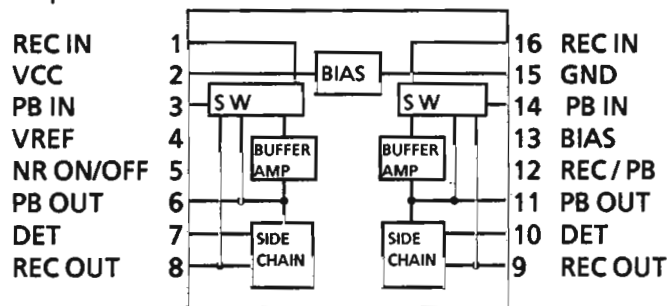

Internal Connection of the Display

■ ELU0001-167 (FL901)

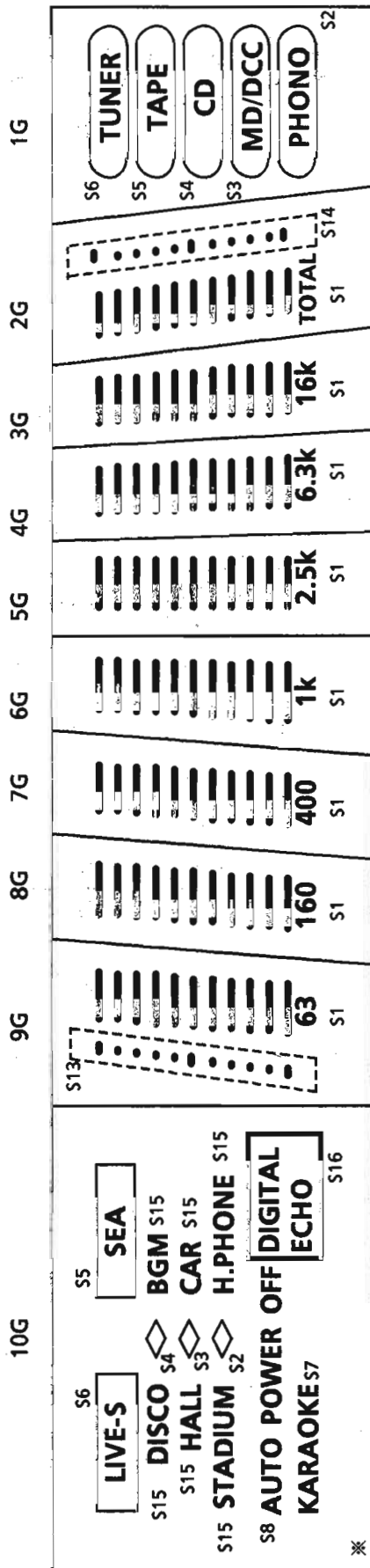

Pin Connection

Pin No.	1	2	3	4	5	6	7	8	9	10	11	12	13	14	15	16	17	18	19	
Electrode	F1	F1	NP	NP	PS2	PS3	PS4	PS5	PS6	PS7	PS8	PS9	PS16	PS10	PS11	PS12	PS13	PS14	PS15	
Pin No.		20	21	22	23	24	25	26	27	28	29	30	31	32	33	34	35	36	37	38
Electrode		PS1	NP	NP	NP	NP	10G	9G	8G	7G	6G	5G	4G	3G	2G	1G	NP	NP	F2	F2

Note: F: Filament NP: No Pin G: Grid P: Anode

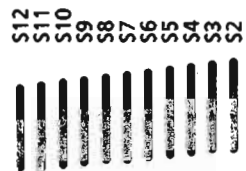

Disassembly Procedures

■ Removing the metal cover

1. Remove the 6 screws fixing the side and back of the cover.
2. Remove the cover.

■ Removing the front panel assembly

1. Remove the metal cover.
2. Disconnect the connectors J103 on the main volume circuit board.
3. Pull out the main volume knob and remove the nut fixing the main volume to remove the main volume circuit board.
4. Disconnect the flat wires J506 and JB701 on the main circuit board and the connectors J301, J302, P331 and P333 on the cassette deck circuit board.
5. Remove the screws (A) fixing the front panel assembly.
6. Release the 3 hooks (C) to remove the assembly.

■ Removing the heatsink cover

1. Remove the 2 screws (D) fixing the cover to remove it.

■ Removing the rear panel

1. Remove the metal cover.
2. Remove the heatsink cover.
3. Remove the 13 screws (E) fixing the panel to remove it.

■ Removing the power ic

1. Remove the metal cover.
2. Remove the rear panel.
3. Disconnect the connector J503 on the main volume circuit board.
4. Take the heatsink with the regulator circuit board and the amplifier circuit board out.
5. Remove the screws fixing the power ic to separate the amplifier circuit board and the heatsink and unsolder the power ic.

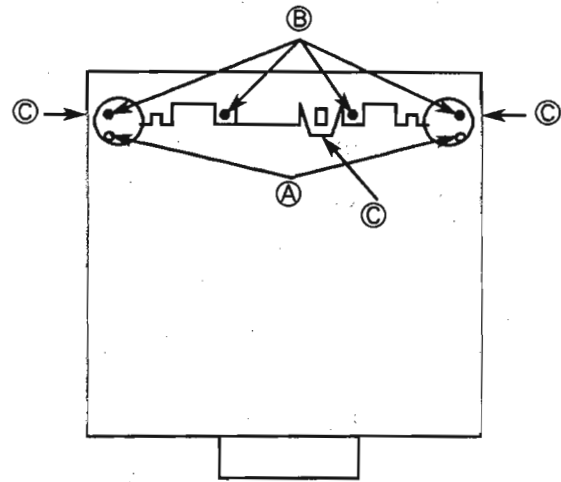

Figure1 Bottom view

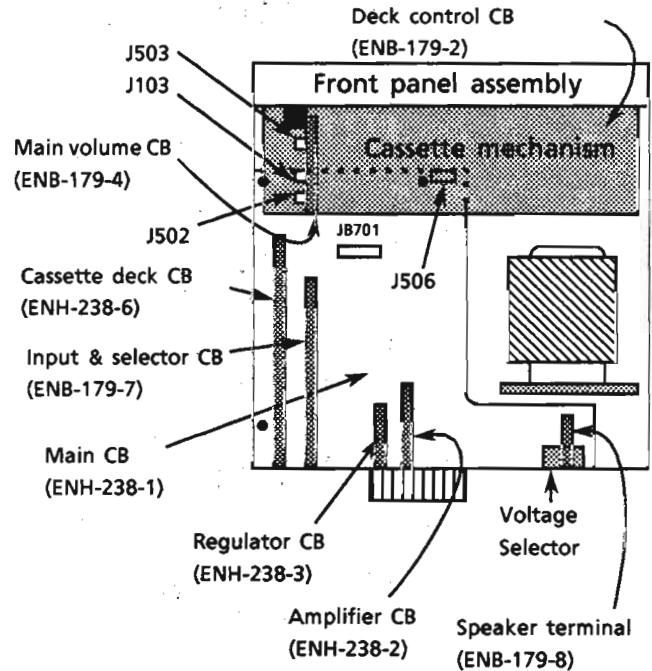

Figure2 Top view

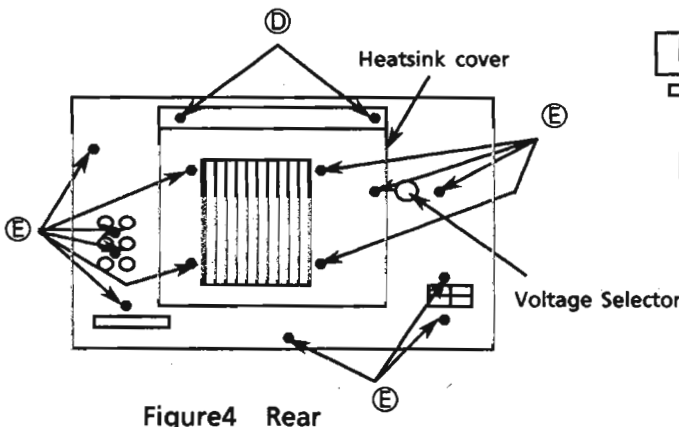

Figure4 Rear

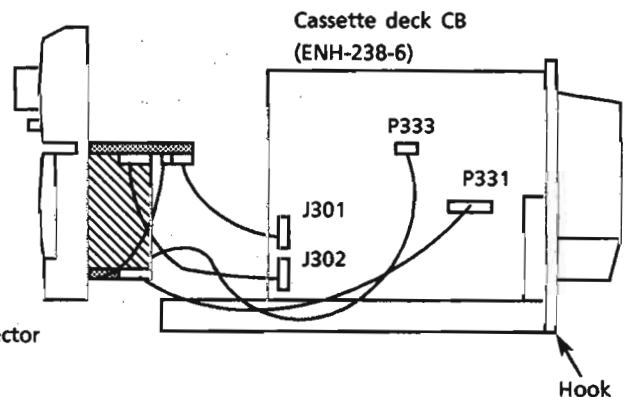

Figure3 Right side

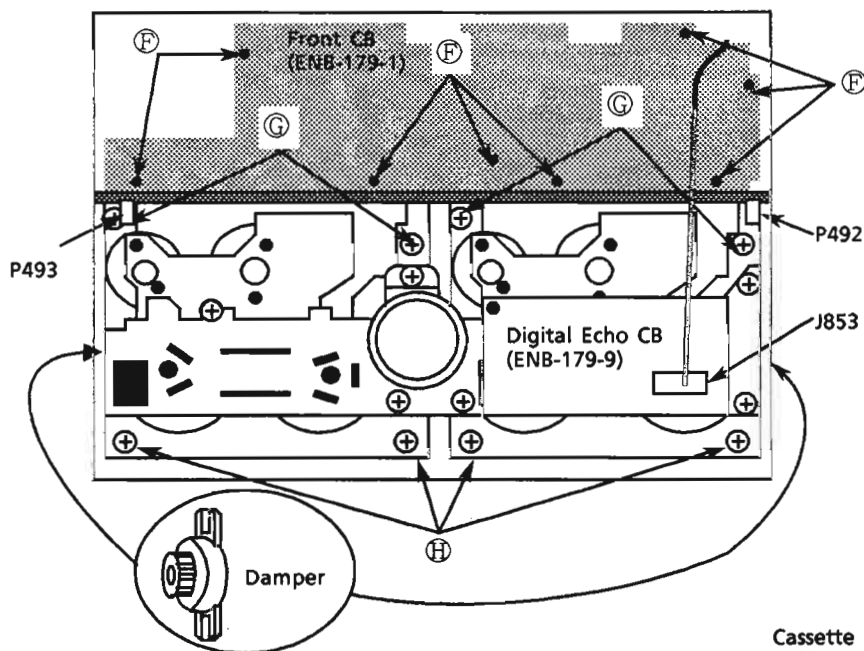

Figure 5 Back of the front panel assembly

■ Removing the cassette mechanism assembly

1. Remove the metal cover.
2. Remove the front panel assembly.
3. Disconnect the connectors P492, P493 on the deck control circuit board and remove the flat wire from J853 on the digital echo circuit board (Figure 5).
4. Remove the 8 screws ① and ② fixing the assembly.
5. Remove the assembly and remove the screw fixing the digital echo circuit board to remove the CB.

■ Removing the cassette holders

1. Remove the cassette mechanism assembly.
2. Remove the holder springs (Figure 6).
3. Remove the damper to remove the holder.

■ Removing the cassette lids

1. Open the cassette door to slide the lid up.

■ Removing the deck control circuit board

1. Remove the cassette mechanism assembly.
2. Remove the 2 screws ③ fixing the circuit board to pull out the circuit board upward.

■ Removing the deck operation circuit board (ENB-179-3: Figure 6)

1. Remove the cassette mechanism assembly.
2. Remove the cassette holders.
3. Remove the 4 screws ④ fixing the holder bracket to remove the bracket (Figure 1).
4. Remove the 2 screws fixing the deck operation circuit board to remove it.

■ Removing the front CB

1. Remove the metal cover.
2. Remove the mixing and echo level knobs.
3. Remove the front panel assembly.
4. Remove the 8 screws ⑤ fixing the circuit board to remove it.

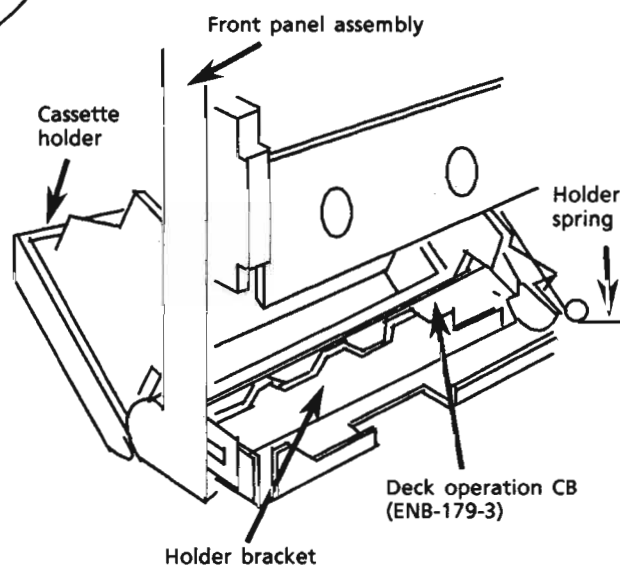

Figure 6

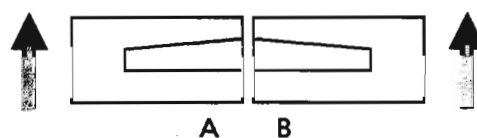

Figure 7

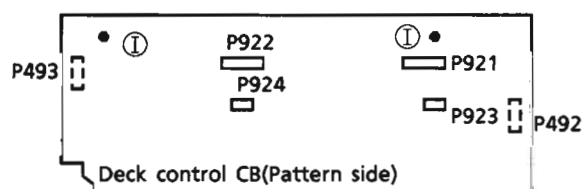

Figure 8

■ Removing the head assembly

1. Remove the cassette mechanism assembly.
2. Disconnect the flexible wire from the relay circuit board (ENB-179-5,6) and remove the FPC holder.
3. Remove the 3 screws ① fixing the head assembly (Fig. 9).

* Installation of the head assembly

When installing the assembly after replacing it, be careful of the direction of the head previously installed.

■ Removing the Reel and cam motor

1. Remove the mechanism assembly.
2. Remove the deck control circuit board.
3. Remove the bracket installed the capstan motor (Refer to figure 11).
4. Remove the 4 screws ① and ② fixing the motors to remove the reel and cam circuit board with the motors .
5. Unsolder the motors to remove the motors.
Do not add the stress to the motor terminals.

■ Removing the capstan motor

1. Remove the mechanism assembly.
2. Remove the deck control circuit board.
3. Remove the 7 screws ③ fixing the bracket on which the capstan motor is installed (Figure 11).
4. Release the hooks fixing the bracket with the motor.
6. Remove the 2 screws fixing the motor to remove it.

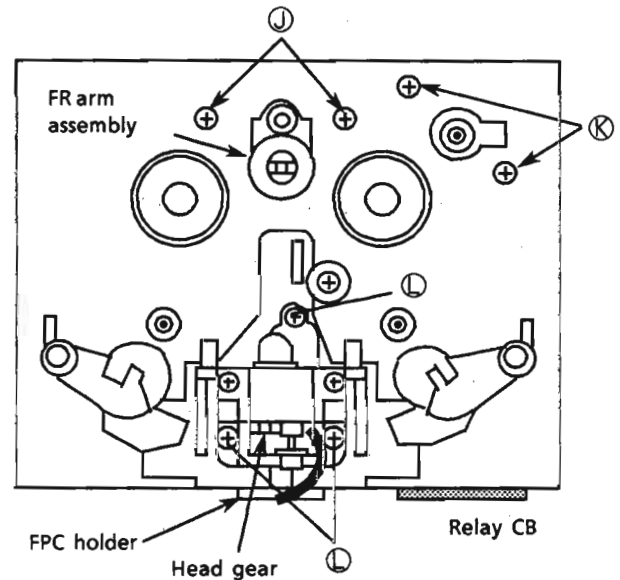

Figure9 Front of the cassette mechanism

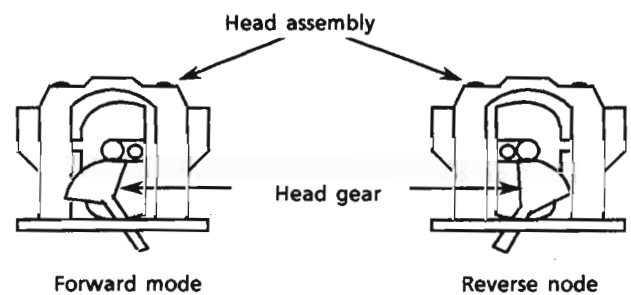

Figure10 Relation between the direction and the head gear

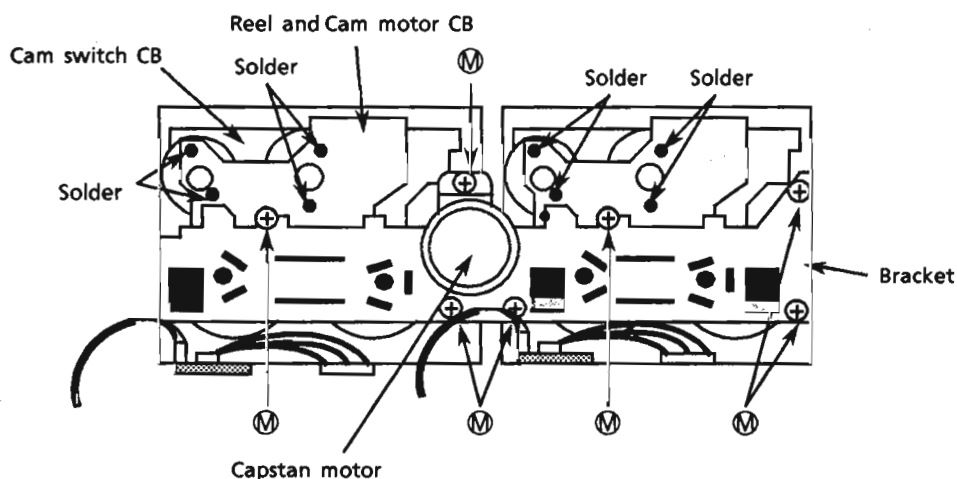

Figure11 (The digital echo CB is removed)

■ Removing the pinch roller arm assembly

1. Release the hooks holding the assembly to remove it (Figure 12).

■ Removing the flywheel

1. Remove the mechanism assembly.
2. Remove the deck control circuit board.
3. Remove the 7 screws (M) fixing the bracket on which the capstan motor is installed (Figure 11) and remove the bracket.

The belts become free at the same time.

4. Remove the flywheels.

Installing

Install the flywheels and the belts to the mechanism as shown in figure 13. When putting the belts on the hanger, put the belt B first.

At last, install the bracket with the capstan motor to put the belts on the pulleys (Figure 14).

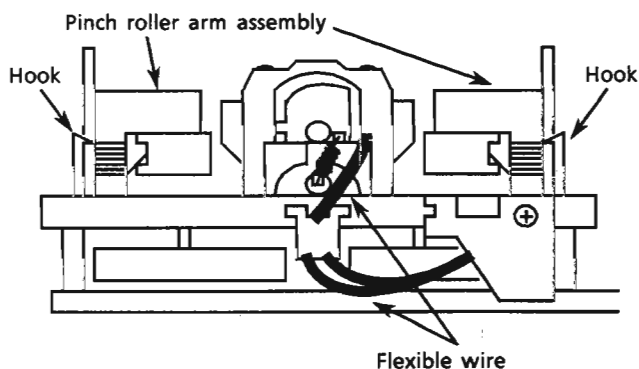

Figure12 Bottom view of the cassette mechanism

■ Removing the cam switch circuit board

1. Remove the flywheels.
2. Remove the reel and cam motor circuit board.
2. Release the hook and the screw fixing the cam switch circuit board to remove the circuit board.

* When installing the cam switch circuit board, assemble the circuit board so that the part (N) meets part (O) (Figure 15).

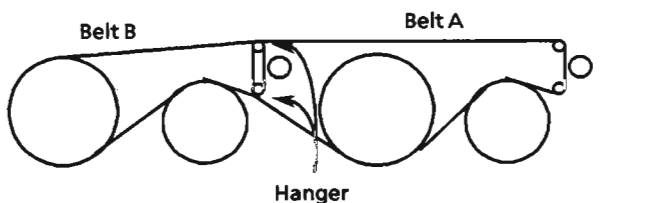

Figure13

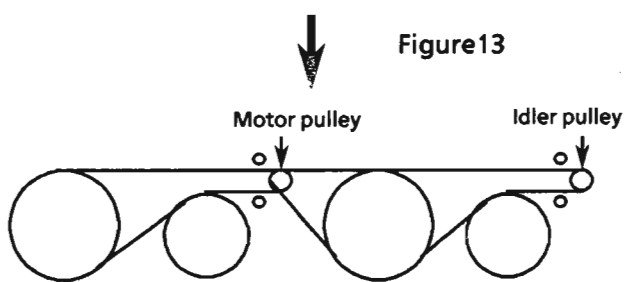

Figure14

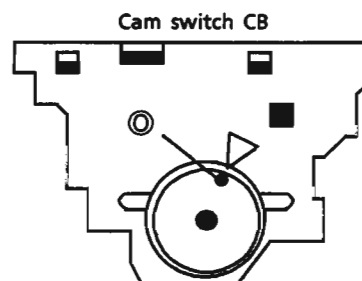
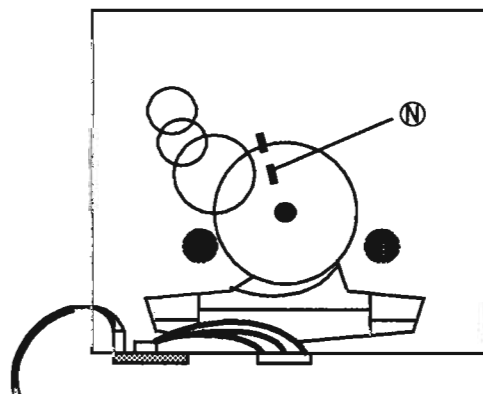

Figure15

Adjustment Procedures (Cassette Deck)

1. Measuring instruments

Audio frequency signal generator (0dbS output at the 600 ohm output terminal from 50Hz to 20KHz)

Electronic voltmeter

Frequency counter

Wow & Flutter meter

Distortion Meter with band pass filter

Attenuator (600 ohm impedance)

A resistor with 600Ω

Standard Tape

0dbS = 0.775V

Tape No.	Frequency	Level (Wow & Fkutter)	Purpose
VTT-703L	10kHz	- 10dbS	Head azimuth , Frequency Response
VTT-712	3000Hz	0dbS 0.025%WRMS	Tape Speed , Wow & Flutter
VTT-724	1kHz	- 4dbS	Standard Level
TMT-6447 , TMT-6448	-	-	Music Scan
TMT-7088	-	-	Recording standard Normal : UR
AC-712	-	-	Recording standard METAL : MA
AC-513	-	-	Recording standard CrO ₂ : SA
CTG-N(CT-100M)	-	-	Forward/reverse play torque measuring
TW-2231	-	-	Feed forward/rewind torque measuring
C-120 Tape	-	-	Confirming the tape running

2. Adjustment and repairing the mechanism

Item	Adjustment method	Standard value	Remarks
Head azimuth	<p>Deck A</p> <ol style="list-style-type: none"> 1. Connect an electronic voltmeter to the DOLBY TP (figure 3) to playback VTT-703L. 2. Adjust screw Ⓐ so that the indication of the voltmeter becomes maximum when PLAY (▶) is pressed. 3. Adjust screw Ⓑ so that the indication of the voltmeter becomes maximum when PLAY (◀) is pressed. <p>Deck B</p> <ol style="list-style-type: none"> 4. Adjust screw Ⓒ so that the indication of the voltmeter becomes maximum when PLAY (▶) is pressed. 5. Adjust screw Ⓓ so that the indication of the voltmeter becomes maximum when PLAY (◀) is pressed. 6. After making the adjustment, apply screw lock to prevent screws Ⓐ, Ⓑ, Ⓒ and Ⓓ coming loose. 	<p>Maximum</p> <p>Refer to Figure 1</p>	<ol style="list-style-type: none"> 1. Refer to figure 1. 2. When the specified characteristic cannot be obtained because of head wear, excessive magnetization, etc., replace the head assembly and adjust the head azimuth. Also, perform the electric adjustment. 3. When there is the difference of more than 3 ~ 4 dB between left and right output levels, replace the head assembly to avoid complaints.
Playback torque	1. Measure the torque in the playback mode by the torqu meter.	26 ~ 62 g-cm	When the standard torque cannot be obtained, replace the FR arm assembly or motor.
Fast forward torque	1. Measure the torque in the fast forward mode by the torqu meter.	80 ~ 170 g-cm	When the standard torque cannot be obtained, replace the FR arm assembly or motor.
Rewind torque	1. Measure the torque in the rewind mode by the torqu meter.	80 ~ 170 g-cm	When the standard torque cannot be obtained, replace the FR arm assembly or motor.
Wow & flutter	<ol style="list-style-type: none"> 1. Connect the wow & flutter meter to the DOLBY TP (figure 3) and play back VTT-712. 2. Its reading should be within 0.2% (WTD). 	Less than 0.2% (WTD)	As a complaint may occur if the wow & flutter fluctuates by 0.1% even though it is allowed in the standard, repairing is required.

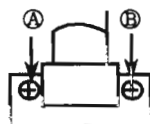

Deck A

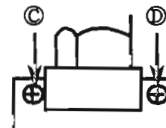

Deck B

Figure 1

3. Electrical Adjustments (Make the following adjustments after adjusting the head azimuth.)

In principle, the adjustments should be made in the following sequence.

Adjustments marked with an asterisk (*) should always be made after the head is replaced

0dBs = 0.775V.

Item	Adjustment Method	Adjustment Location	Standard Value	Remarks
1 Tape Speed	<ol style="list-style-type: none"> 1. Connect a frequency counter to the DOLBY TP (figure 3) and play back VTT-712. 2. Normal speed Adjustment Playback deck B to adjust the semi-fixed resistor R400 on ENB-179-3. 3. Confirm the normal speed of deck A Play back deck A to confirm that the difference between deck A and deck B is within $\pm 51\text{Hz}$. 4. High-speed confirming Play back deck A in high speed dubbing and confirm that the counter indicates 6000Hz. 	R400	3,000 Hz $\pm 10\text{Hz}$ 6,000Hz $\pm 600\text{Hz}$	—
* 2 Standard level (Playback Level)	<ol style="list-style-type: none"> 1. Connect an electronic voltmeter to the DOLBY TP (figure 3). Play back VTT-724 (1 kHz : -4dBs) to adjust the semi-fixed resistors. 	Deck A L: R381 R: R382 Deck B L: R383 R: R384	-5.5dBs (411mV) $\pm 1\text{dB}$	1) The playback level varies when the head is replaced so should be adjusted. Use an electronic voltmeter with an impedance of 100 k Ω or more.
* 3 Playback Frequency Response	<ol style="list-style-type: none"> 1. Connect an electronic voltmeter to the DOLBY TP (figure 3). 2. Play VTT-703L (10kHz : -10dBs) and adjust semi-fixed resistors to obtain the standard values. 	Deck A L: R361 R: R362 Deck B L: R357 R: R358	-11.5dBs (206mV) $\pm 3\text{dB}$	—
* 4 Recording Bias Frequency	<ol style="list-style-type: none"> 1. Connect a frequency counter to the BIAS TP (figure 3), and perform a recording with no signal to adjust bias frequency. 	L331	100 kHz $\pm 6\text{ kHz}$	—
* 5 Record / Play Frequency Response (Bias current)	<ol style="list-style-type: none"> 1. Supply 1kHz and 12.5kHz signals with 30mV to MD/DCC terminals respectively to record them. 2. Connect an electronic voltmeter to the DOLBY TP (figure 3) to confirm the recorded values. 3. If the values are not satisfied, adjust the semi-fixed resistors and record the signals again to confirm the values. 	L: R355 R: R356	$0 \pm 2\text{ dB}$ for 12.5 kHz with 1 kHz as the standard.	Refer to figure 2 below. 1) The recording and playback frequency response of the cassette deck are adjusted by adjusting the bias current. 2) Perform the adjustment with normal tape and confirm that the values are within the range for metal tape.
* 6 Record / Playback Sensitivity	<ol style="list-style-type: none"> 1. Input a 1 kHz (-8.2dBs: 300mV) signal to MD/DCC terminals and record it on the left and right channels. 2. Connect an electronic voltmeter to the DOLBY TP (figure 3) to confirm the recorded levels. 3. If the values are not satisfied, adjust the semi-fixed resistors and record the signal again to confirm the values. 	L: R351 R: R352	-5.5dBs (411mV) $\pm 1\text{dB}$	Adjust with normal tape and make sure that the left / right level difference is 1.0dB or less

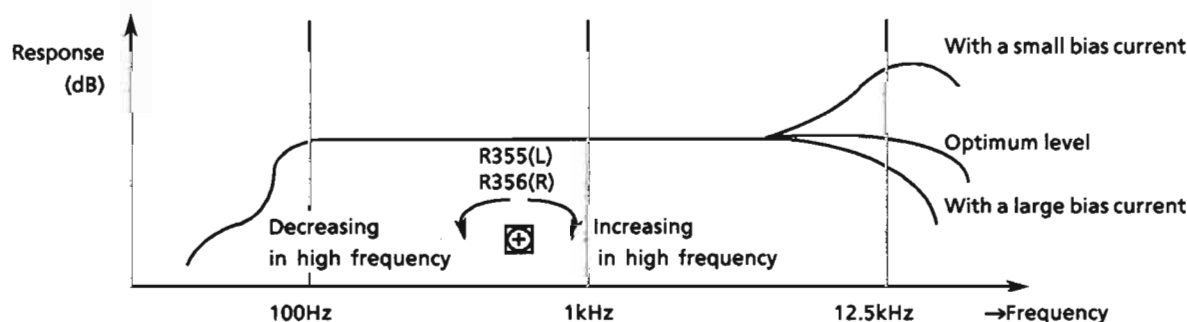

Figure 2

Item	Adjustment Method	Adjustment Location	Standard Value	Remarks
7 Erase ratio check	1. Record a music source using metal tape. 2. Rewind and erase the recorded section. 3. Comfirm nothing can be heard.	-	-	-
8 Auto-stop check	Make sure to operate AUTO STOP at the end of tape running and not to operate on the way of the playing.	-	-	-
9 Music Scan	1. Make sure not to work the music scanning operation at the start of tape wind using TMT-6448. 2. Make sure to work the music scanning operation at the end of tape wind using TMT-6447.	-	-	-

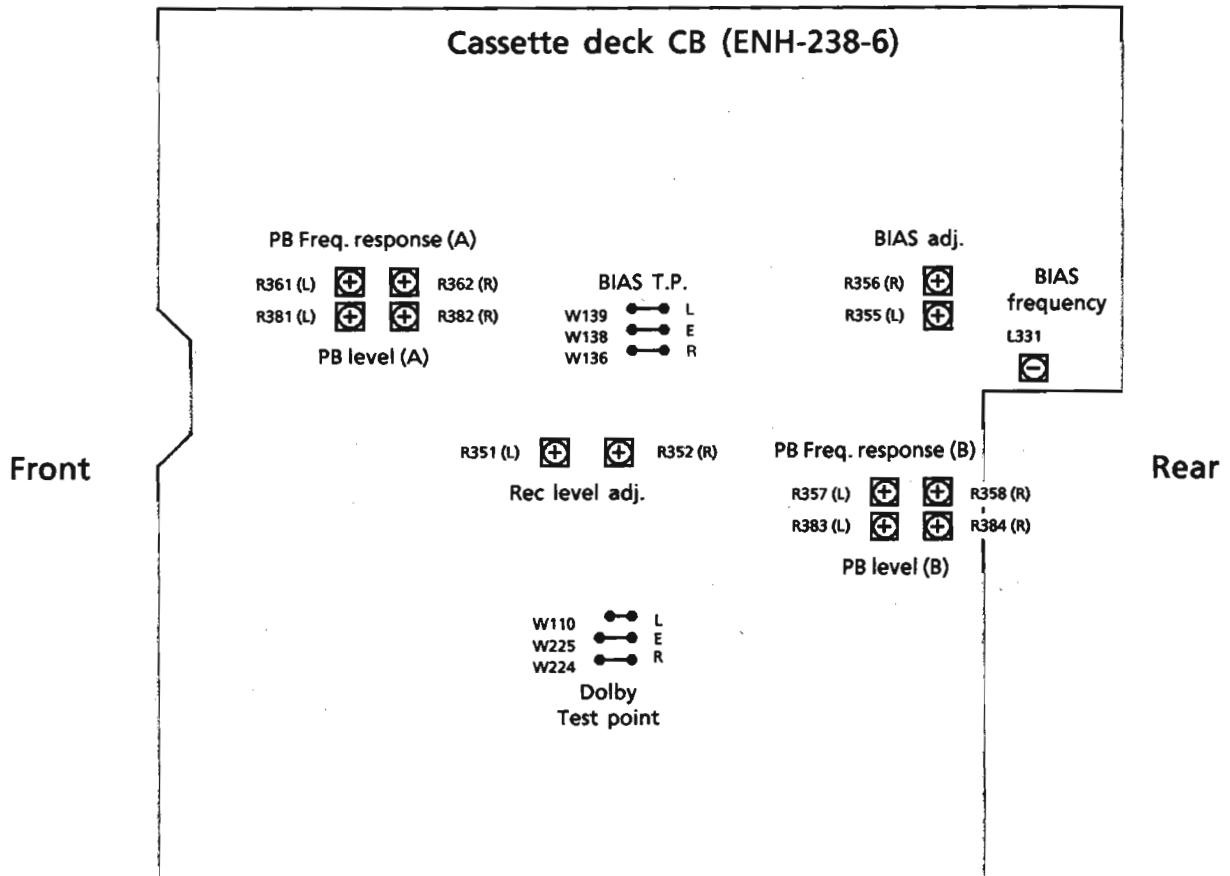
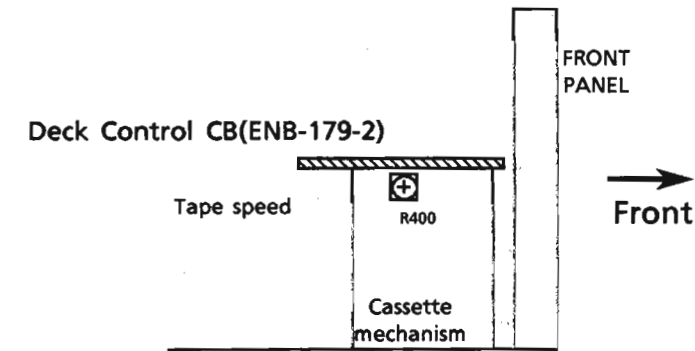
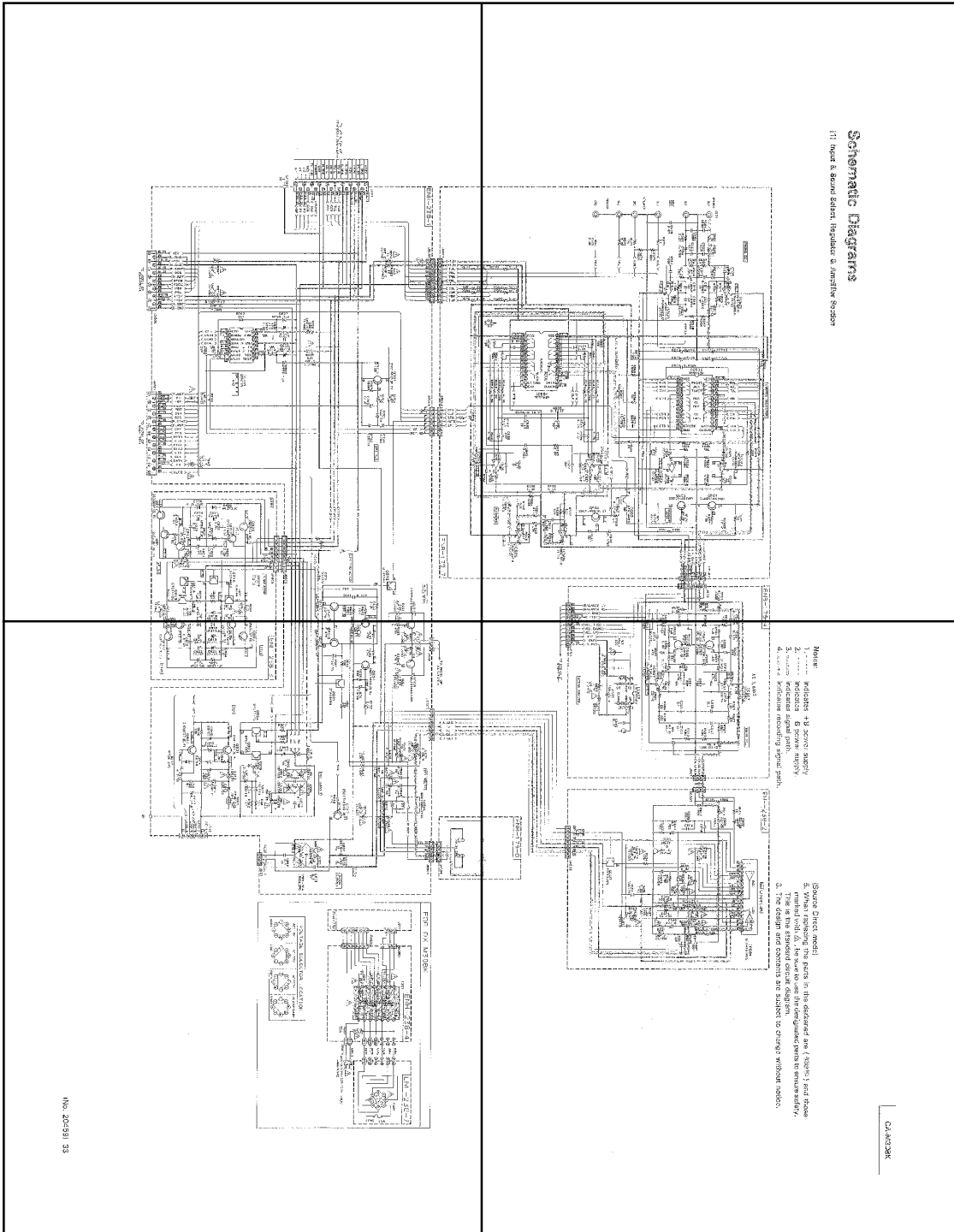

Figure 3

P33-a

P33-b



P33-c

P33-d

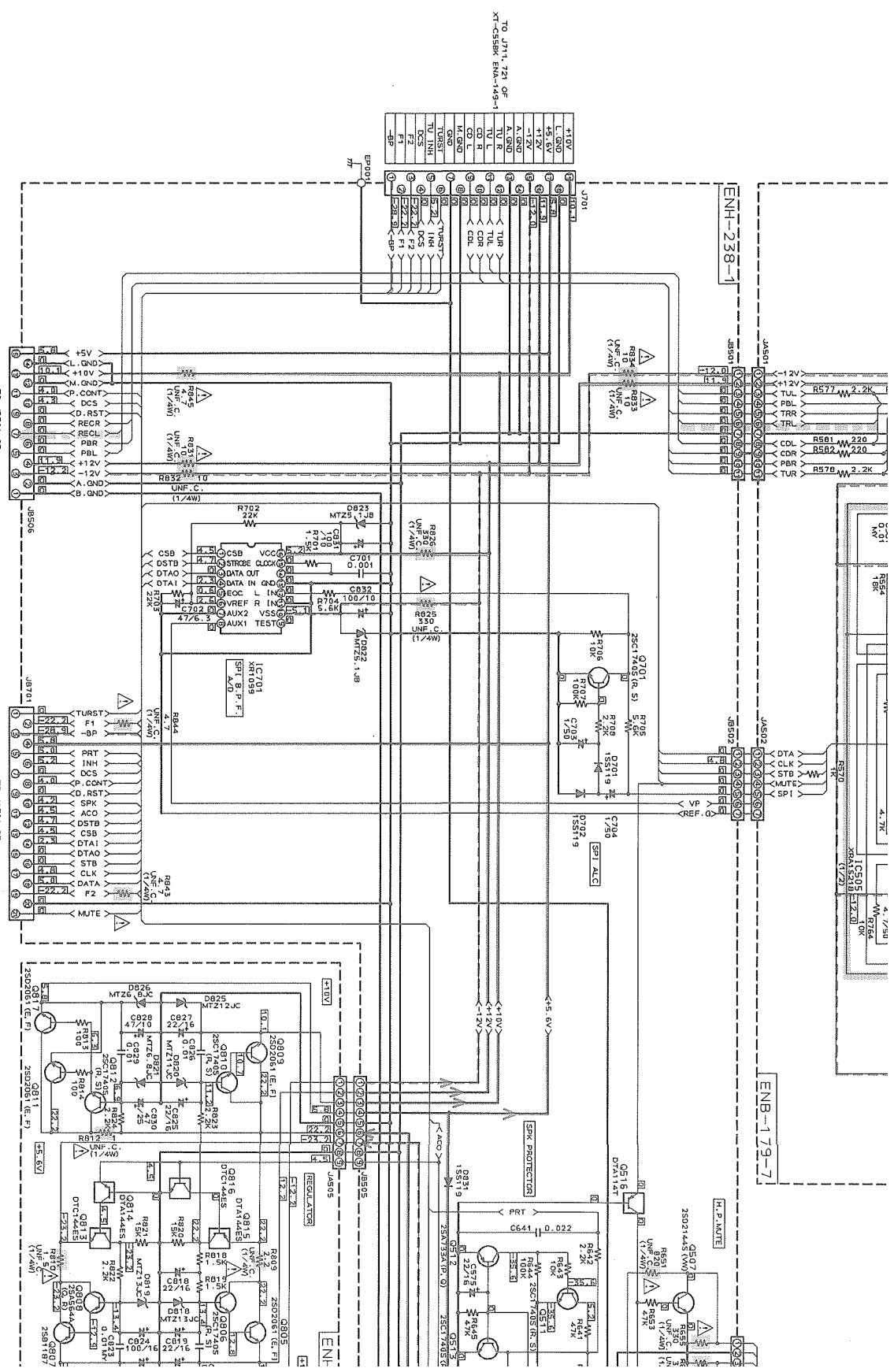

Schematic Diagrams

(1) Input & Sound Select, Regulator & Amplifier Section

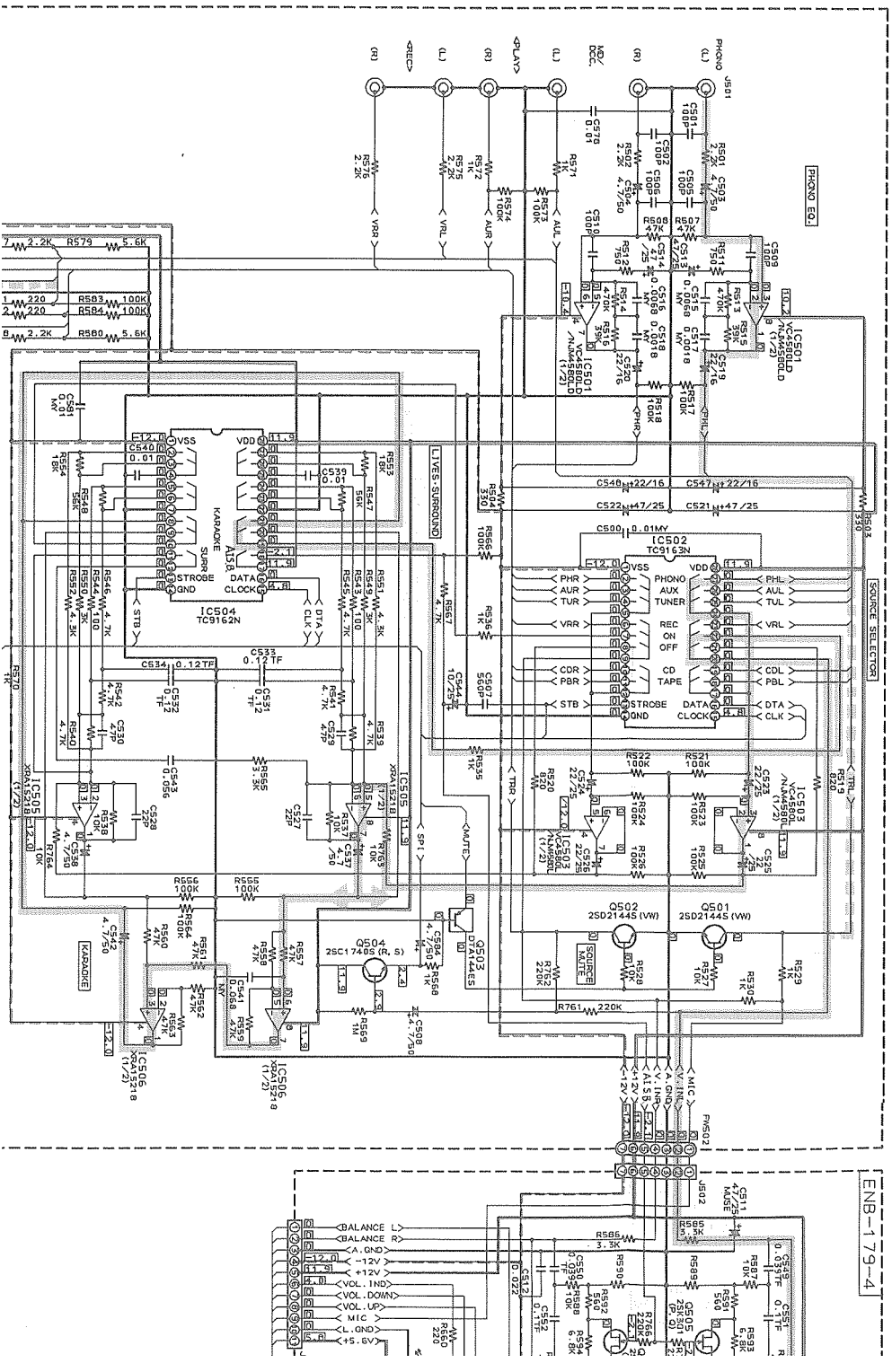

- N
- 1
- 2
- 3
- 4

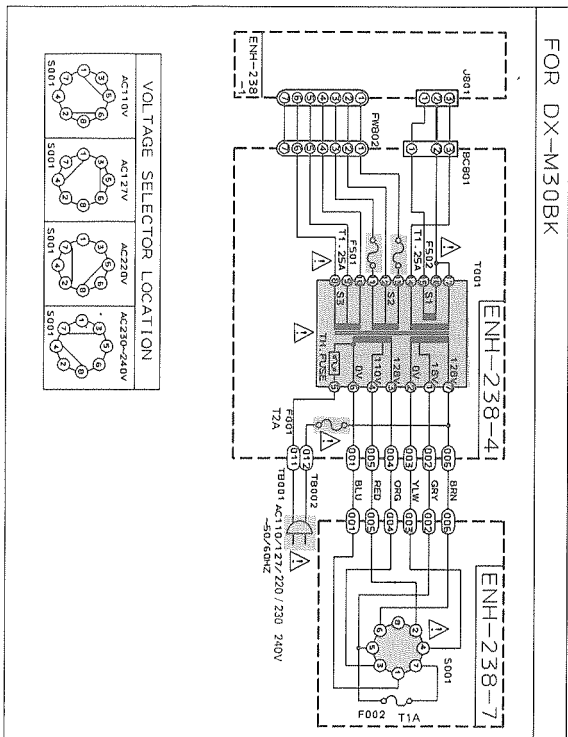
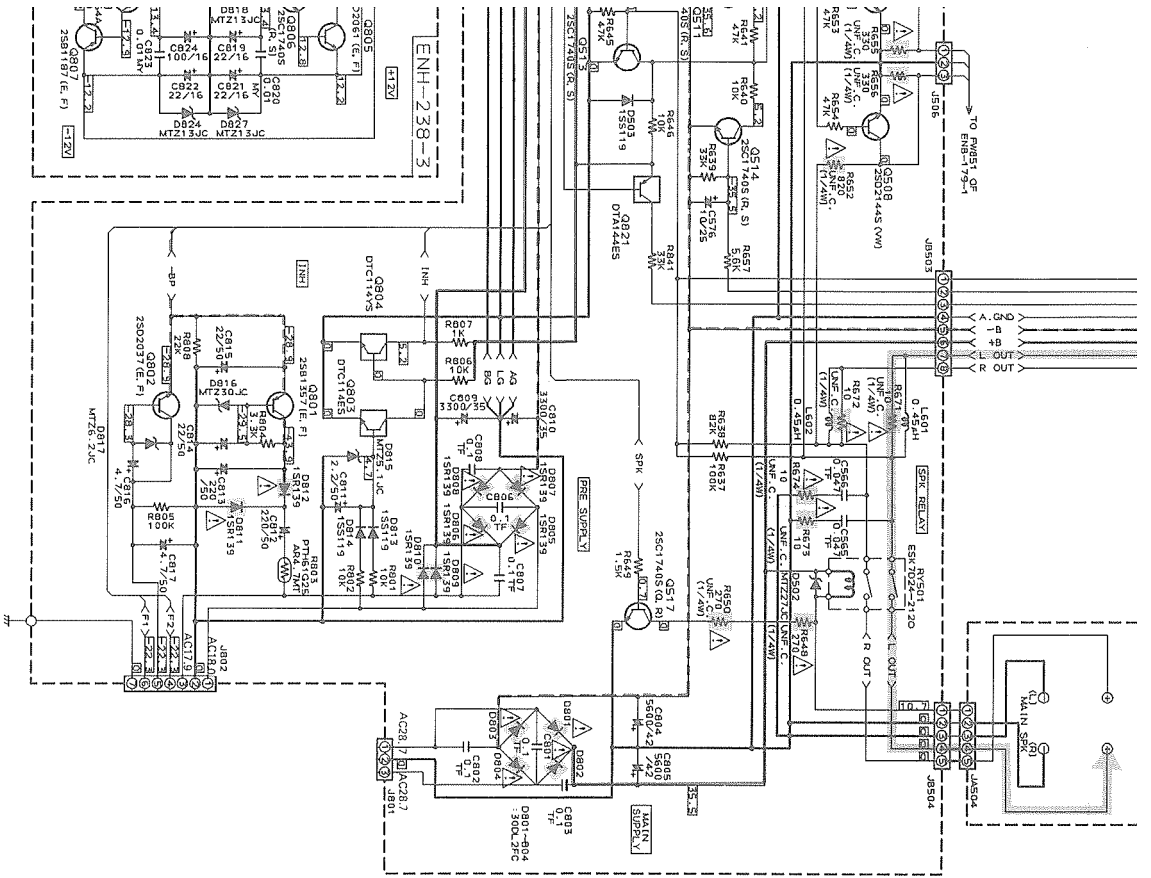

- Notes:
1. — indicates +B power supply
 2. — indicates -B power supply.
 3. — indicates signal path.
 4. — indicates recording signal path.
- (Source Direct mode)
5. When replacing the parts in the darkened are () and those marked with Δ , be sure to use the designated parts to ensure safety. This is the standard circuit diagram.
 6. The design and contents are subject to change without notice.

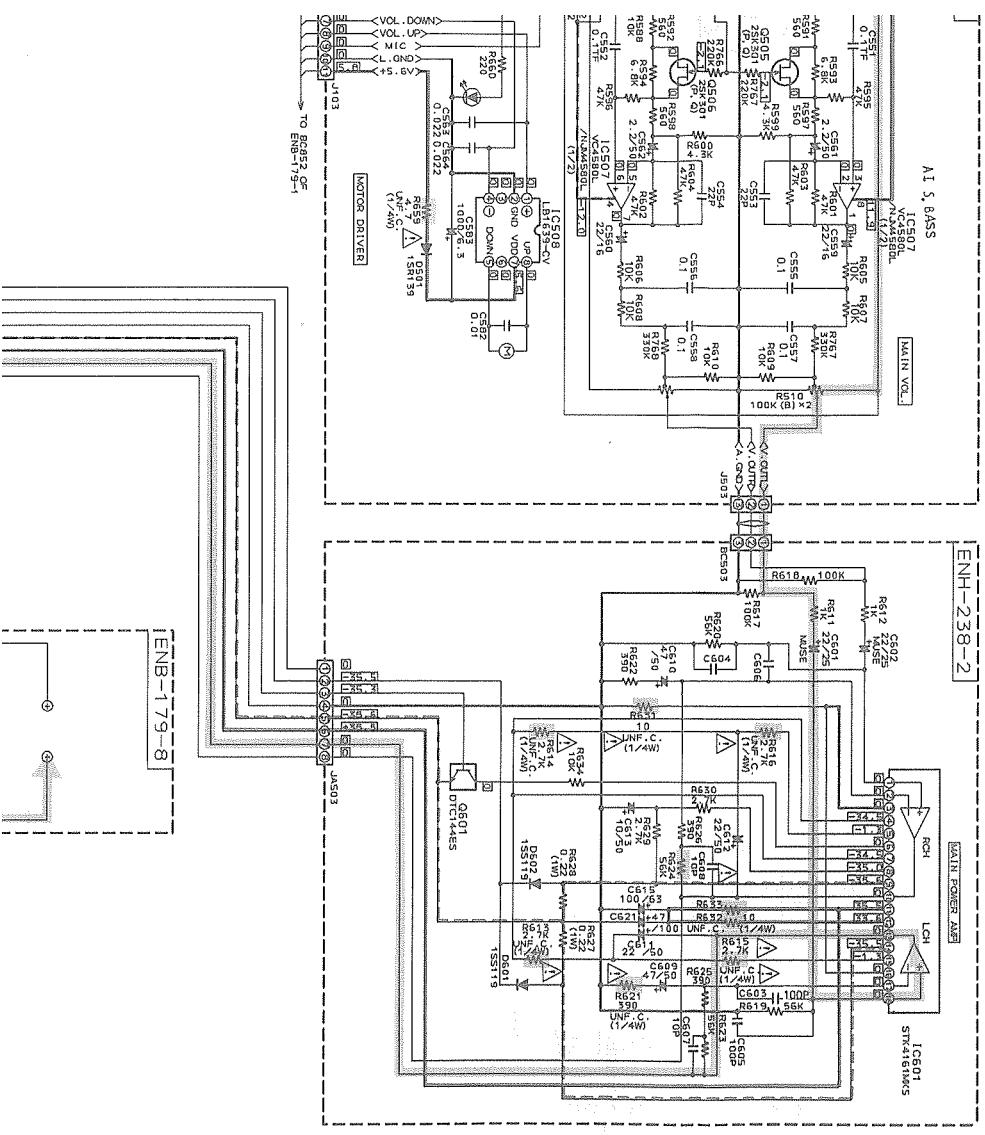

P34-a

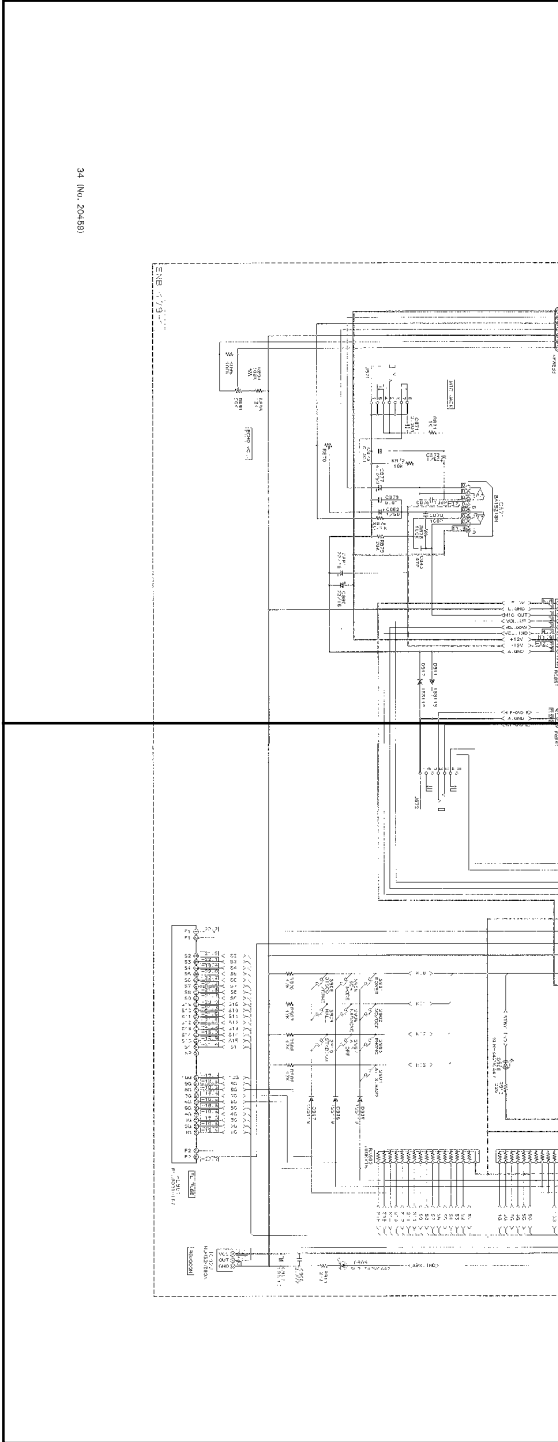

P34-c

P34-b

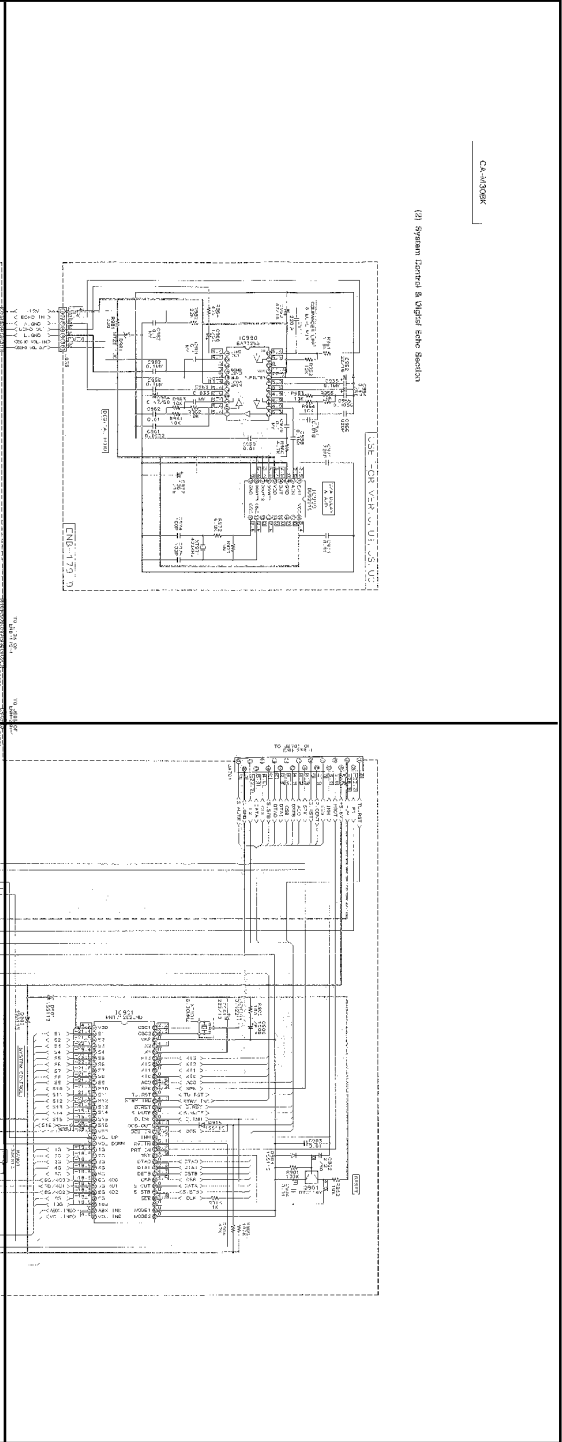

P34-d

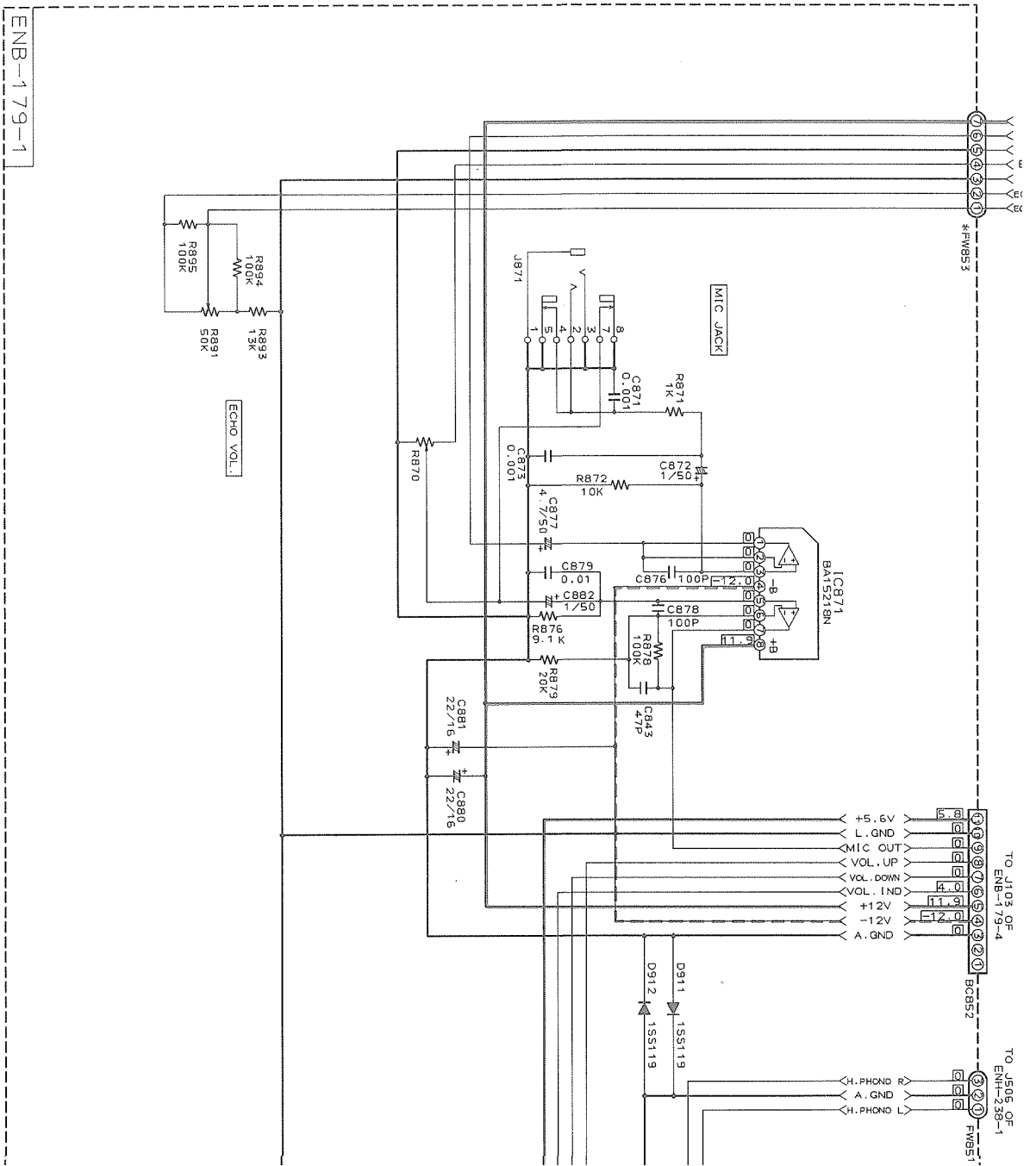

(2) System Control & Digital Echo Section

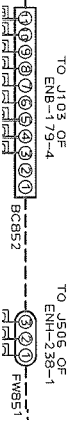
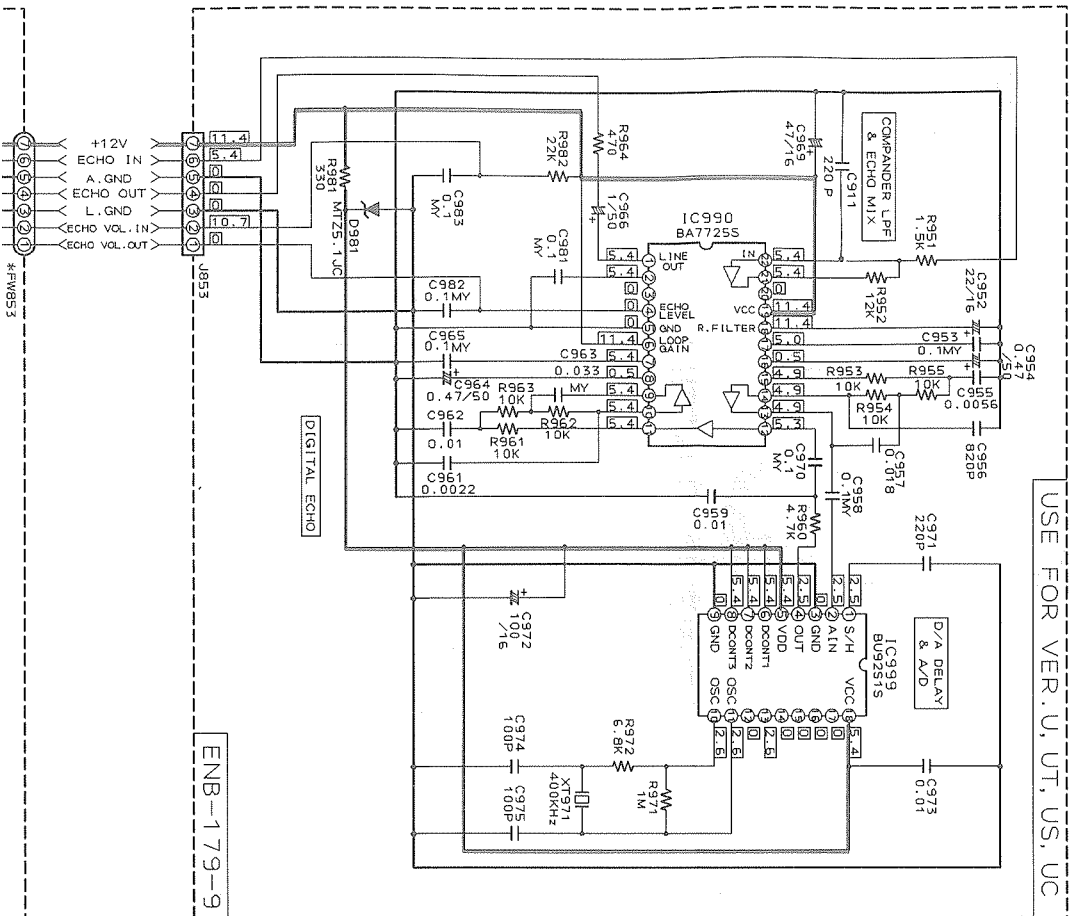

TO JB701 OF

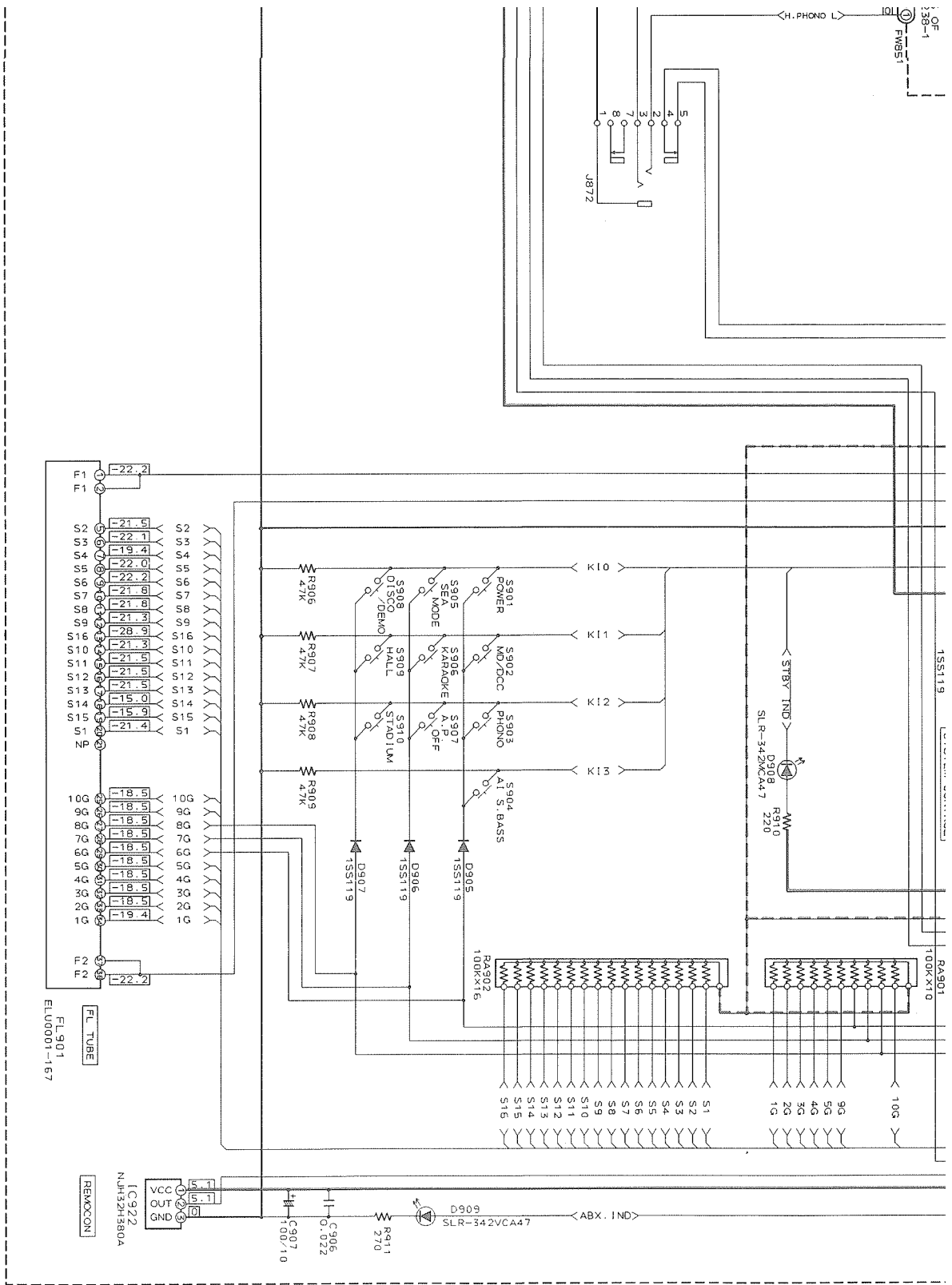

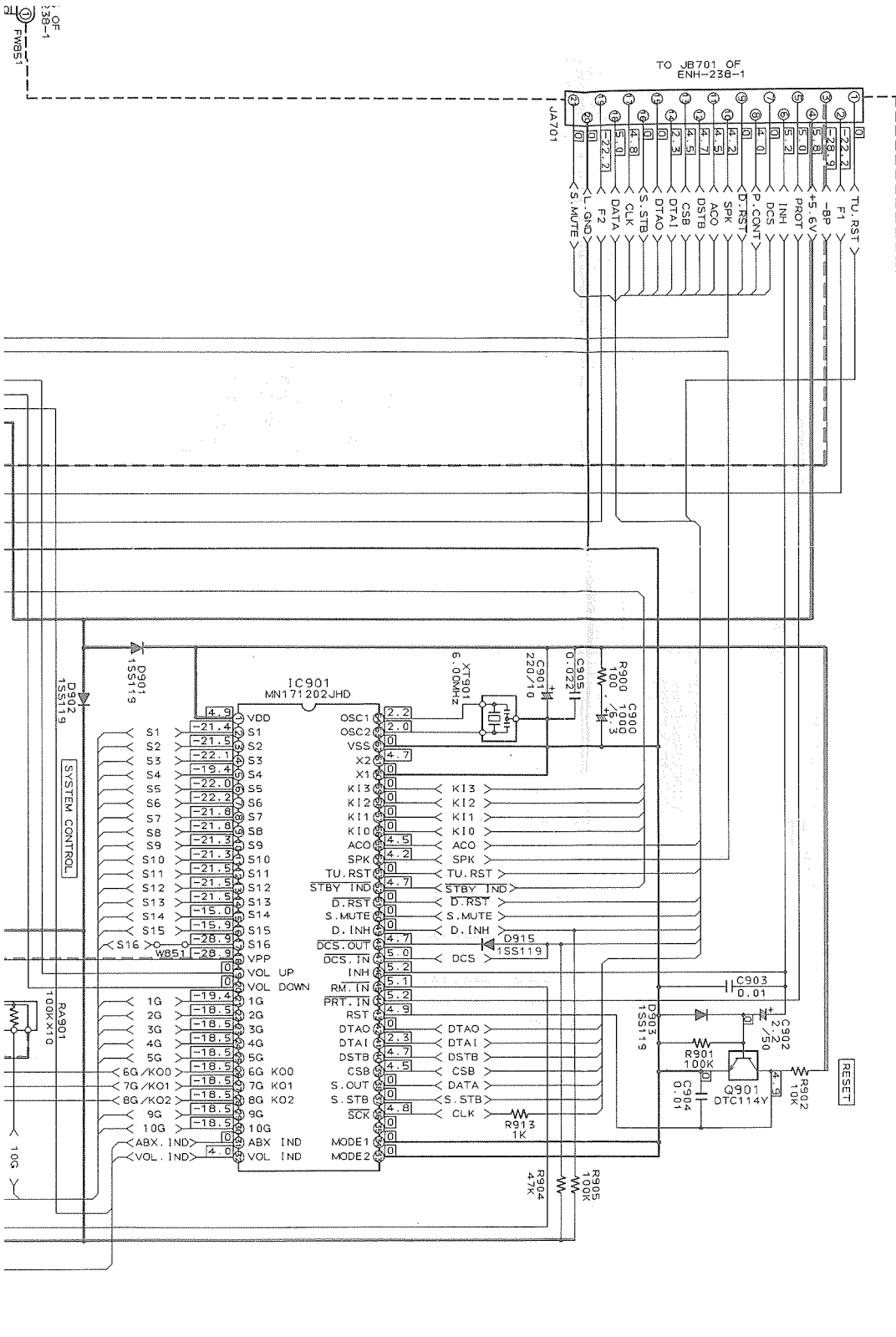

P35-a

P35-b

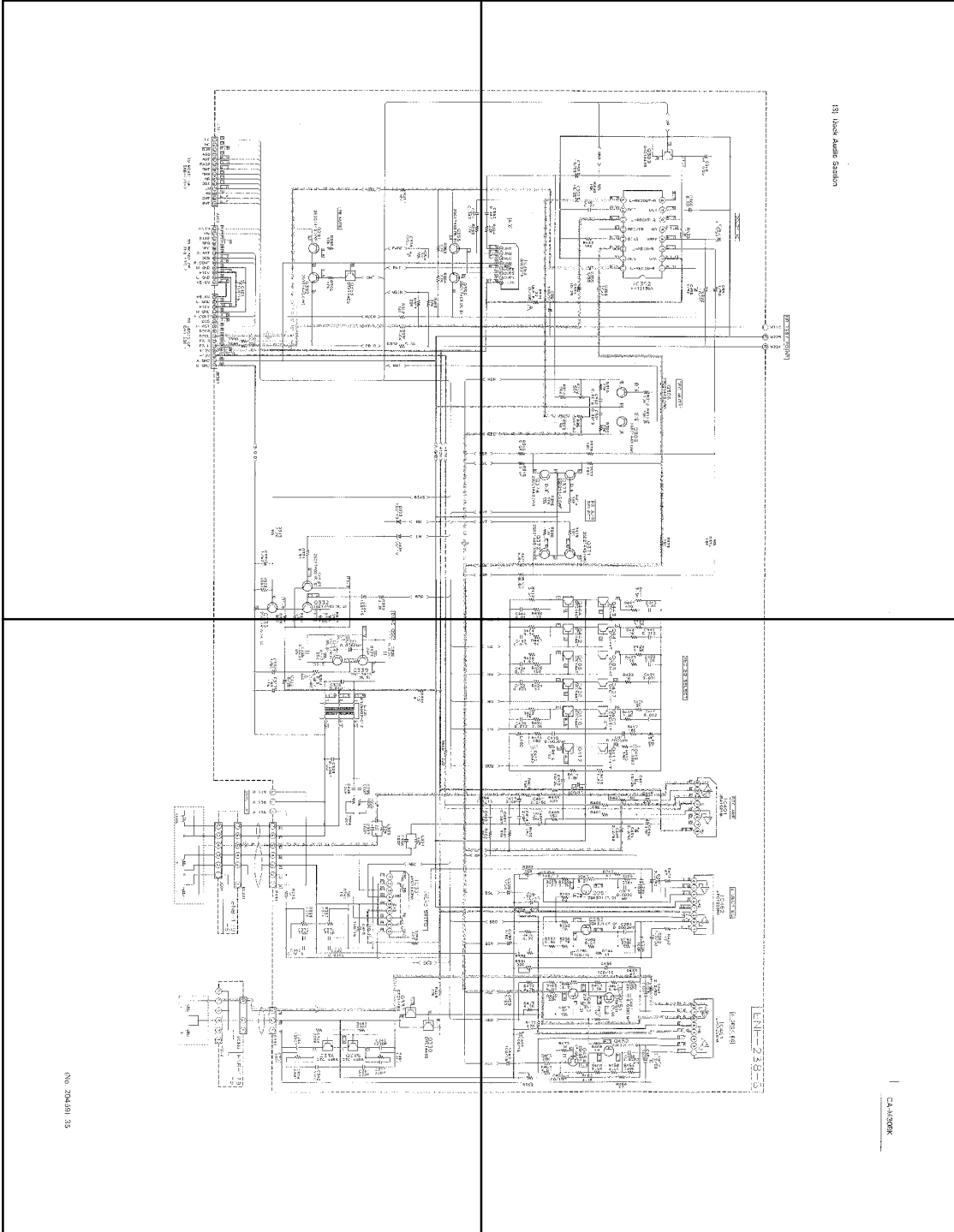

P35-c

P35-d

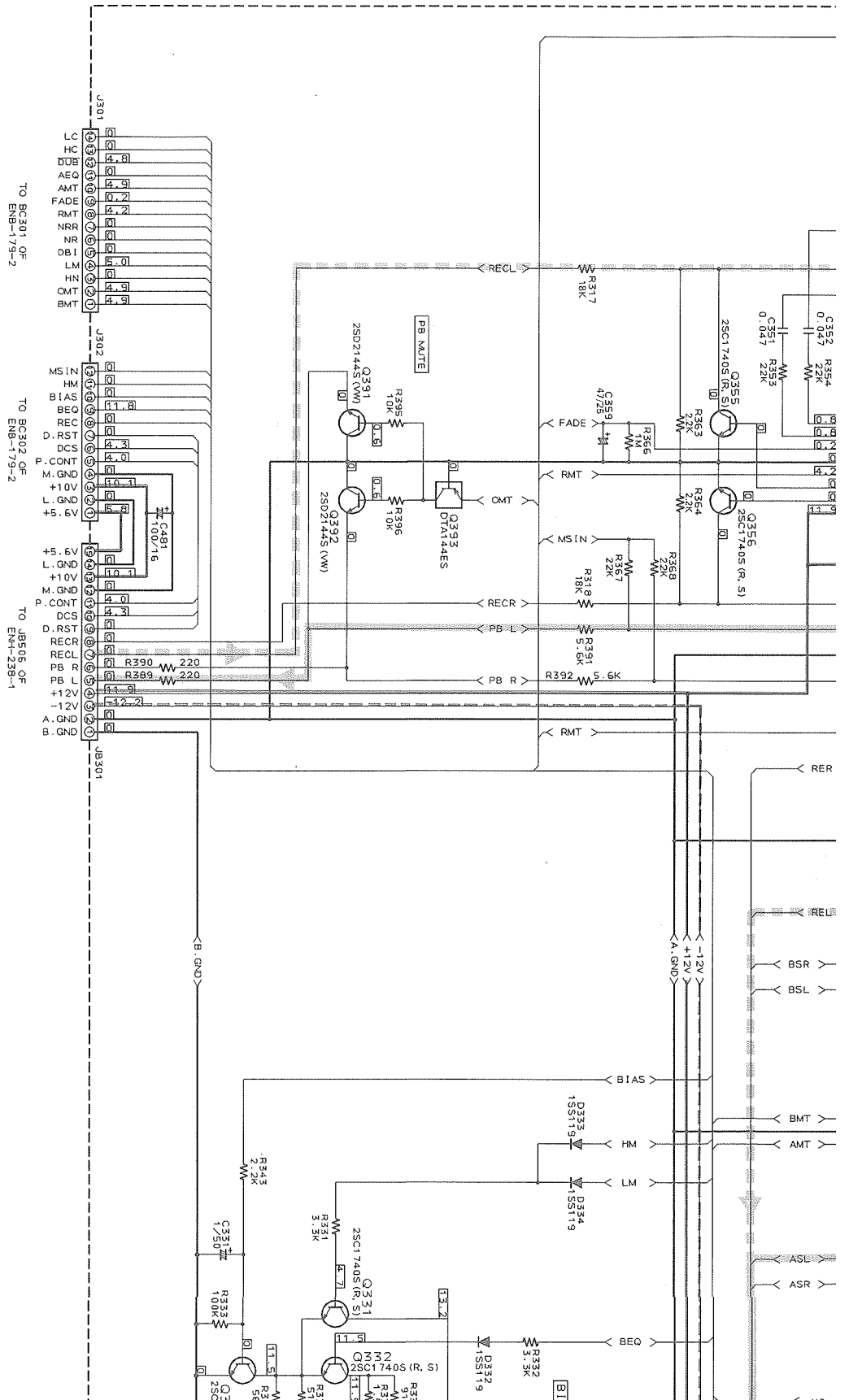

(3) Deck Audio Section

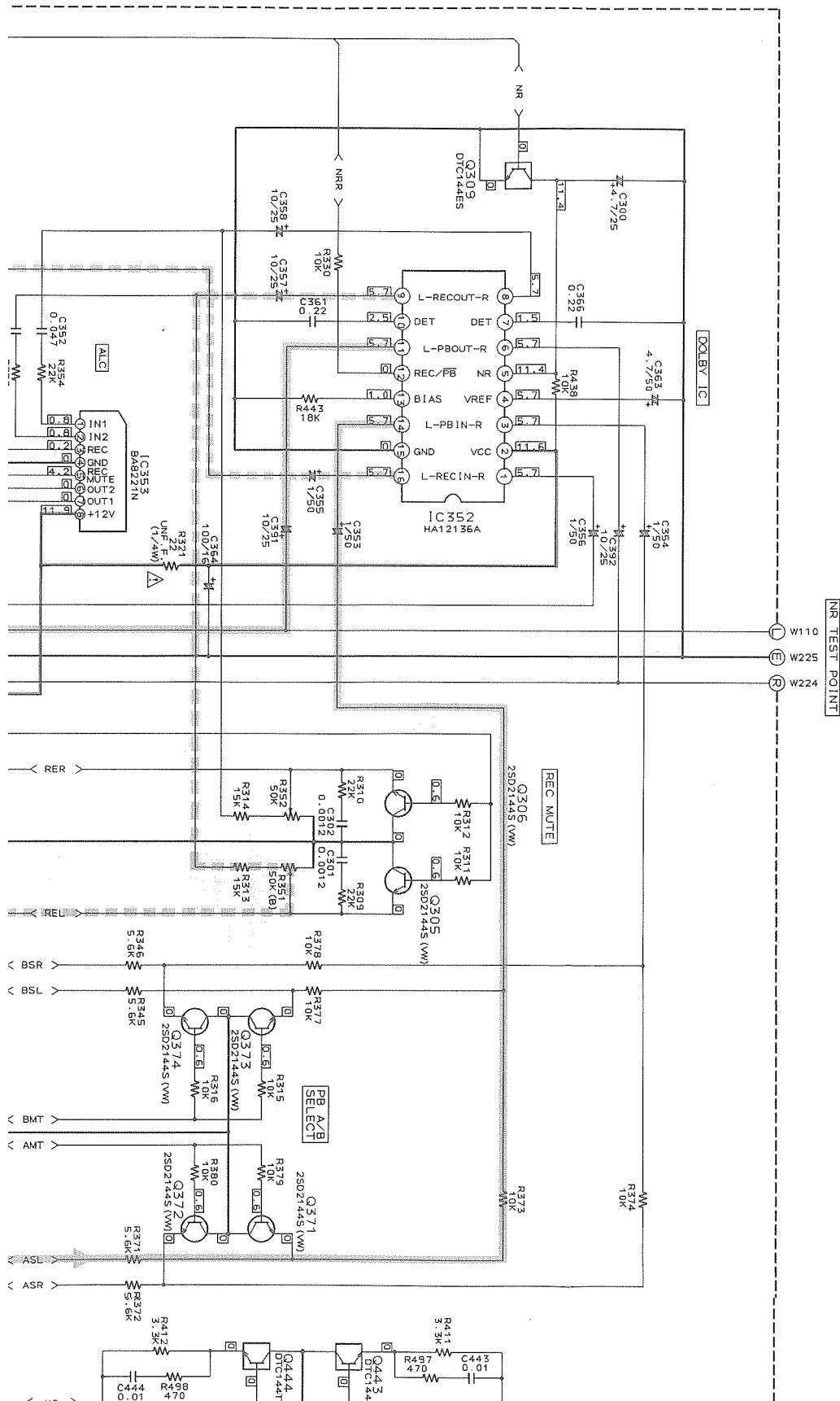

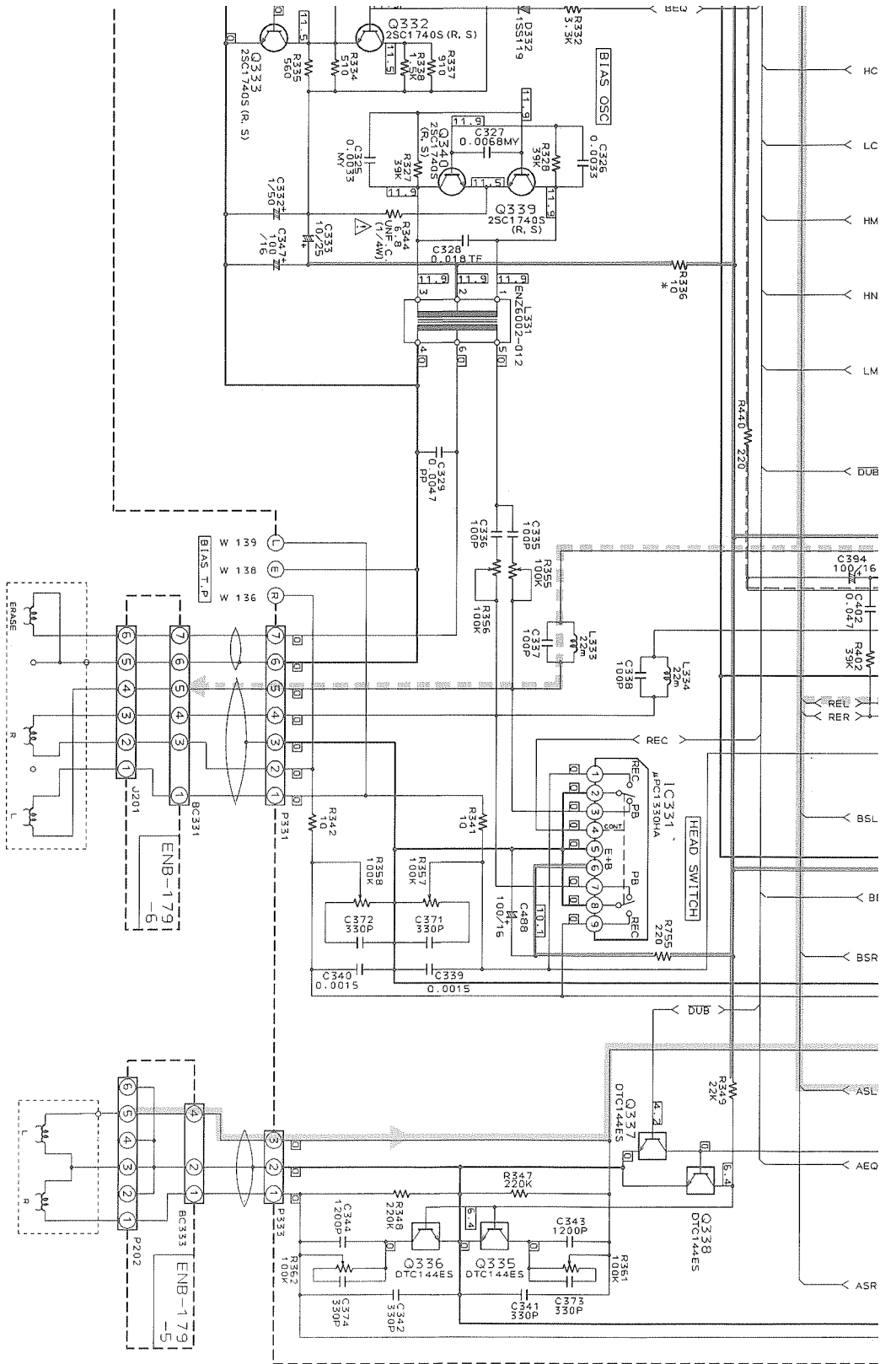

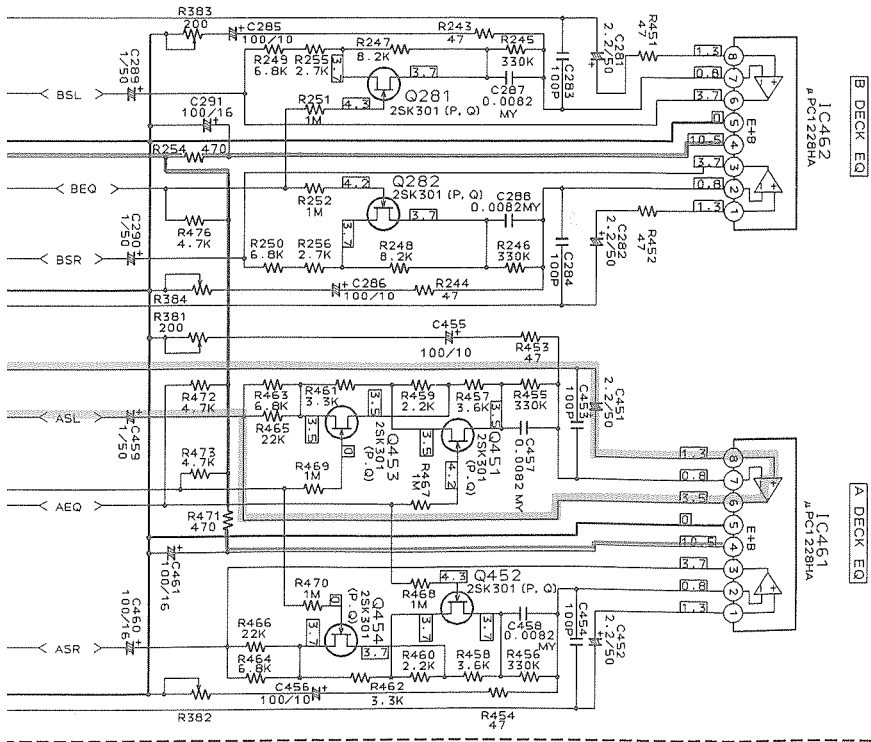
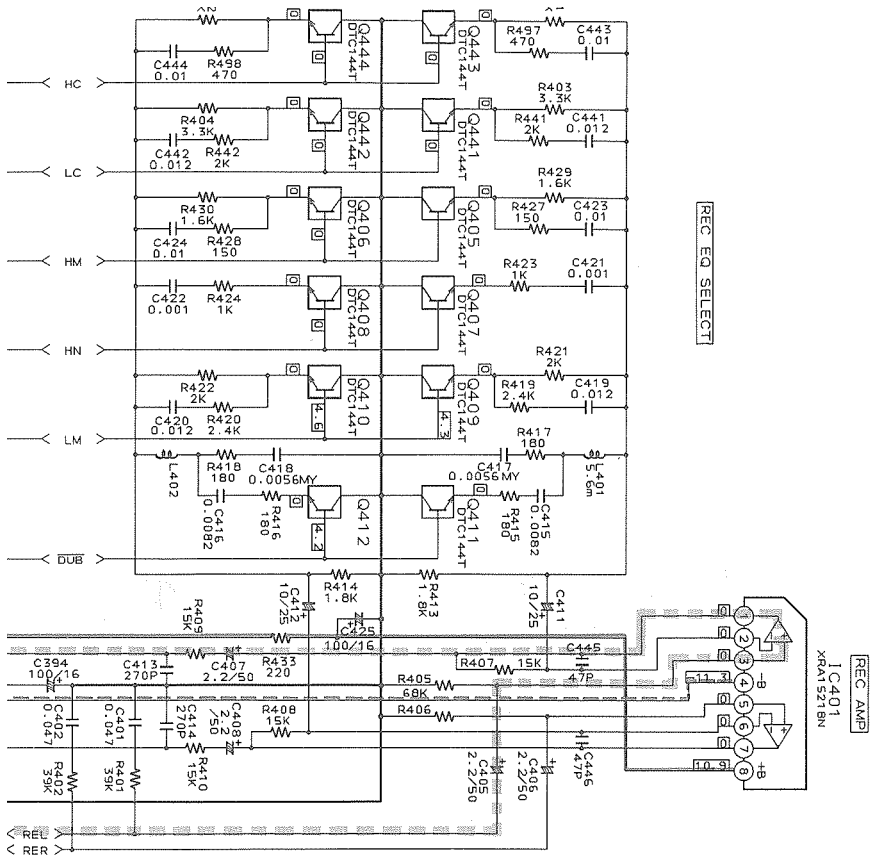

CA-M30BK

P36-a

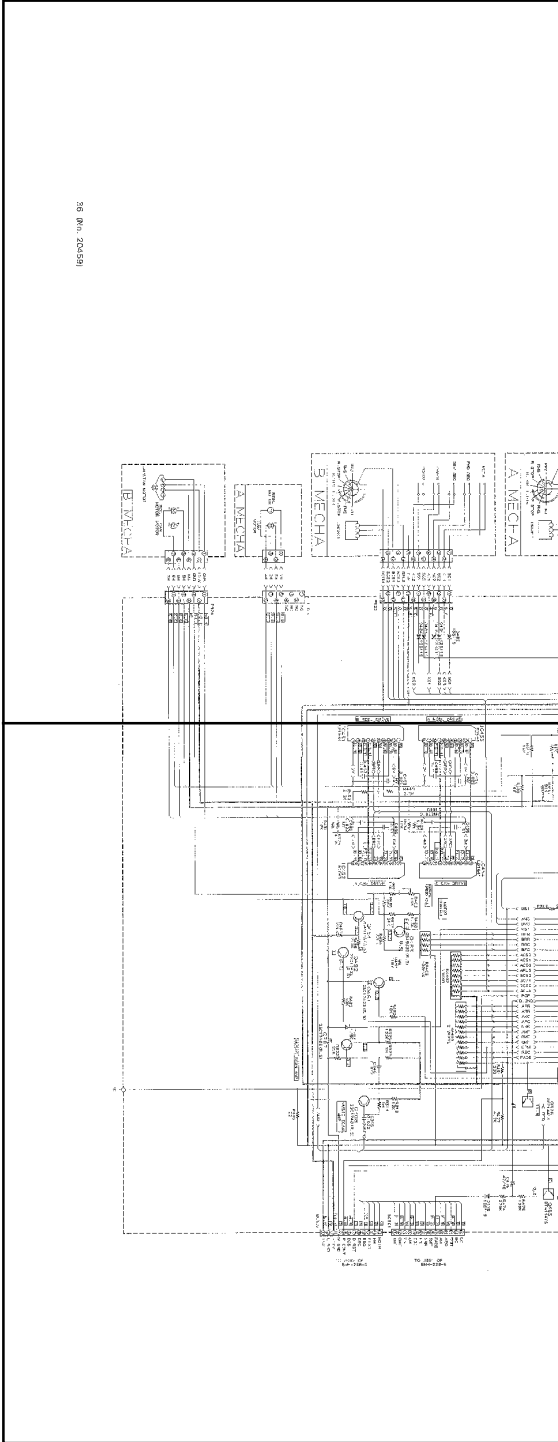

26 (Rev. 2/24/58)

P36-b

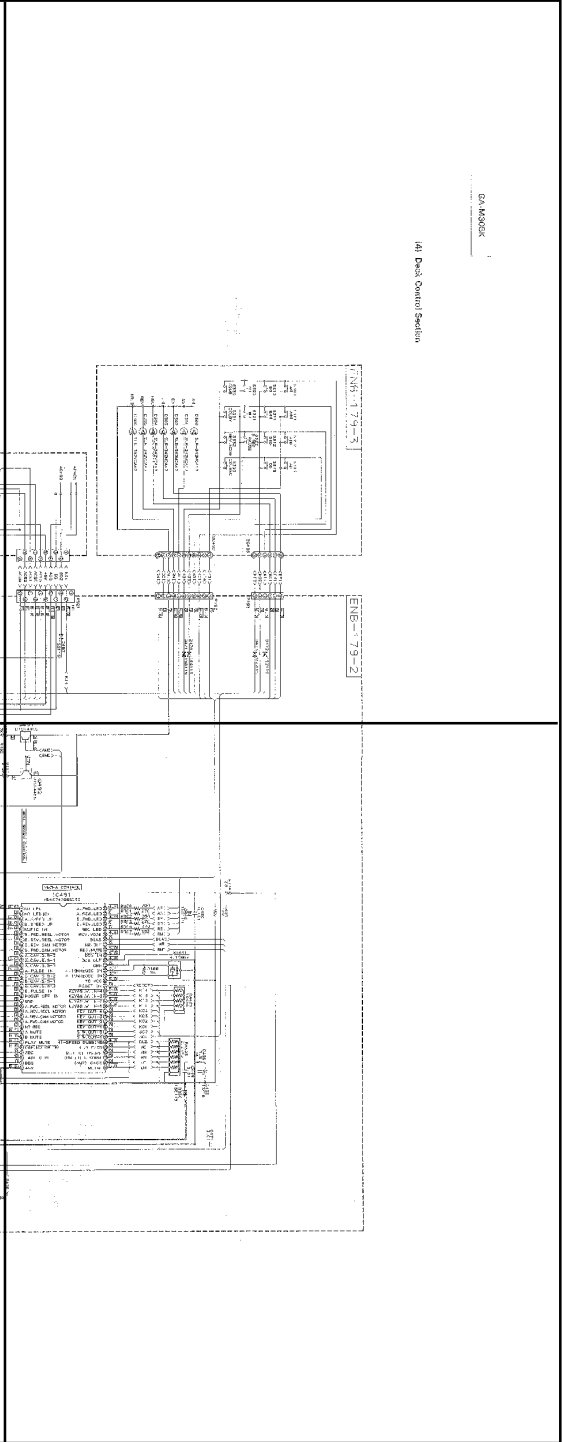

P36-c

P36-d

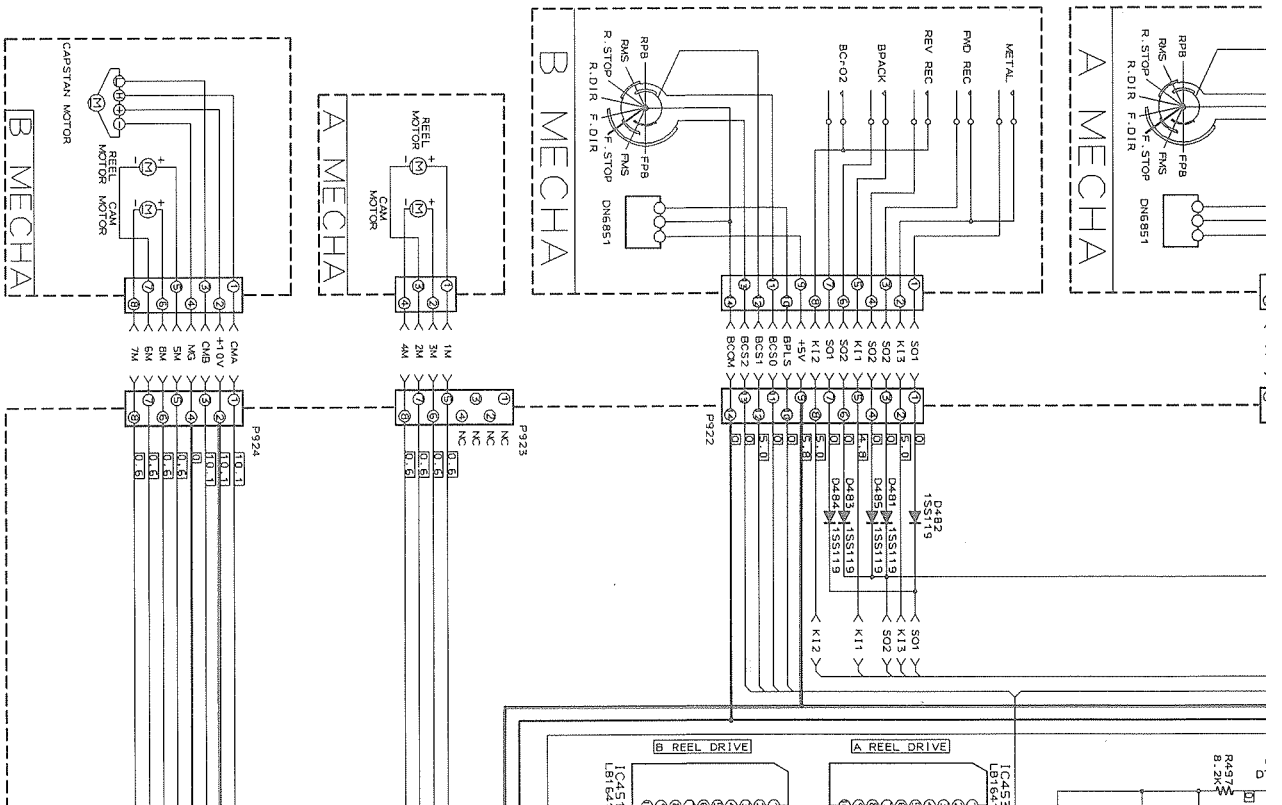

(4) Deck Control Section

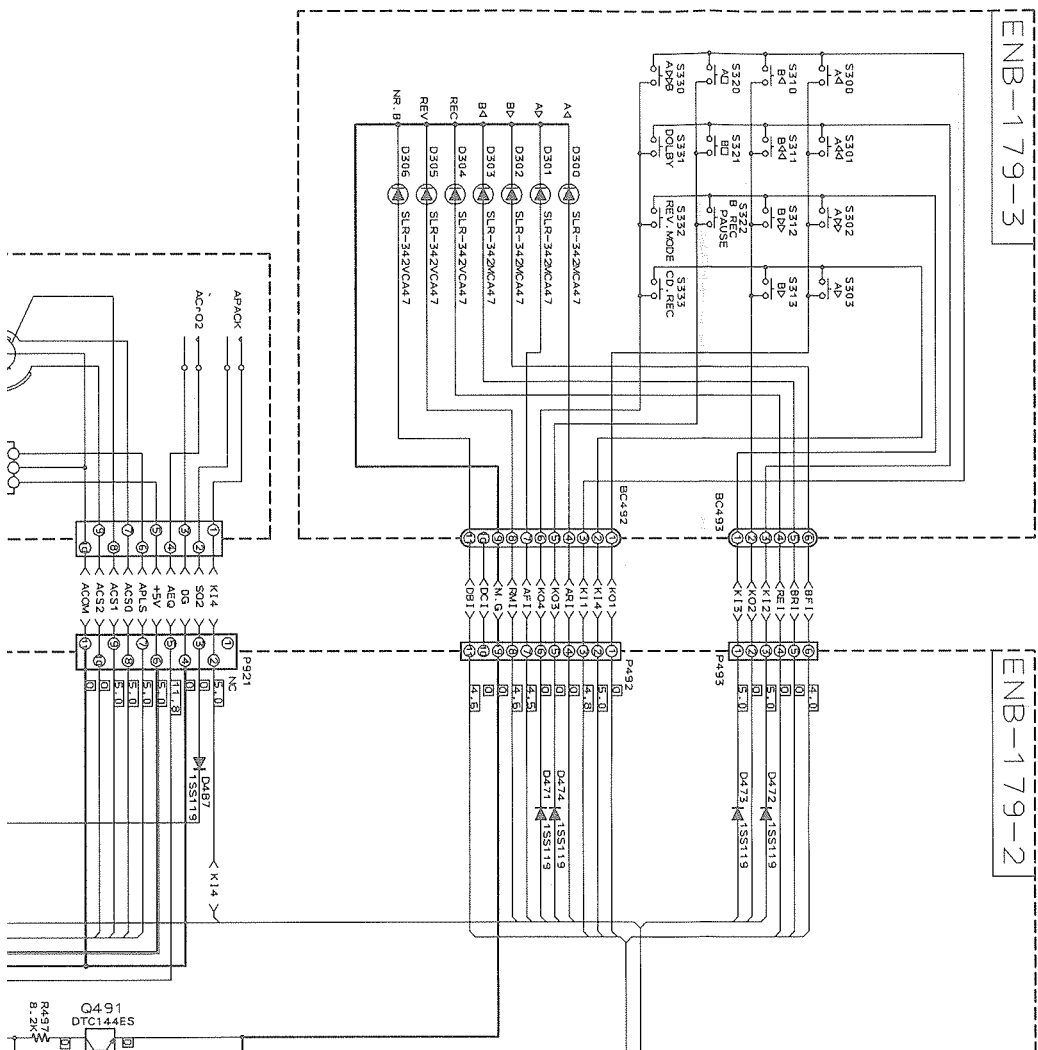

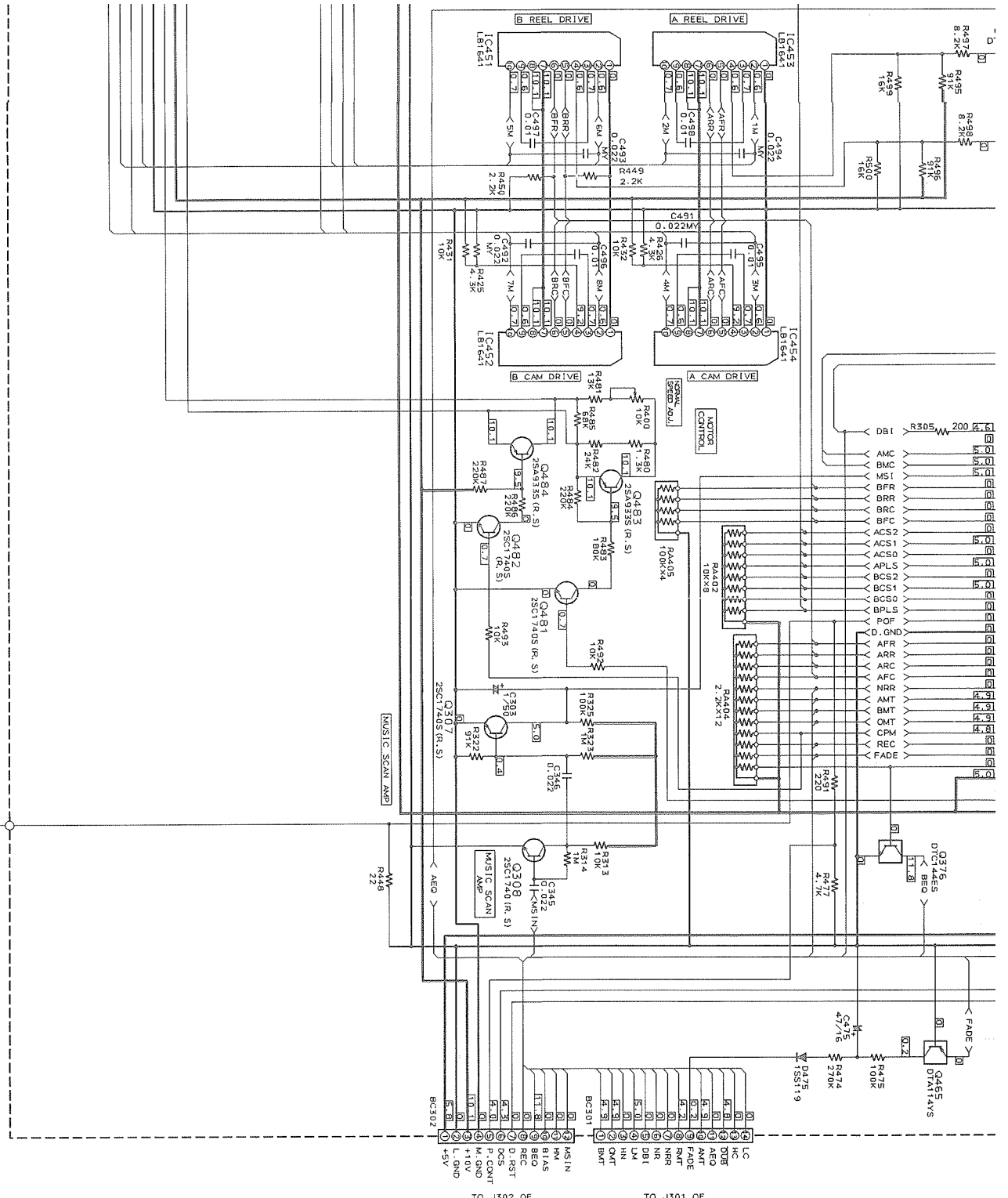

TO J302 OF ENH-238-6
 TO J301 OF ENH-238-6

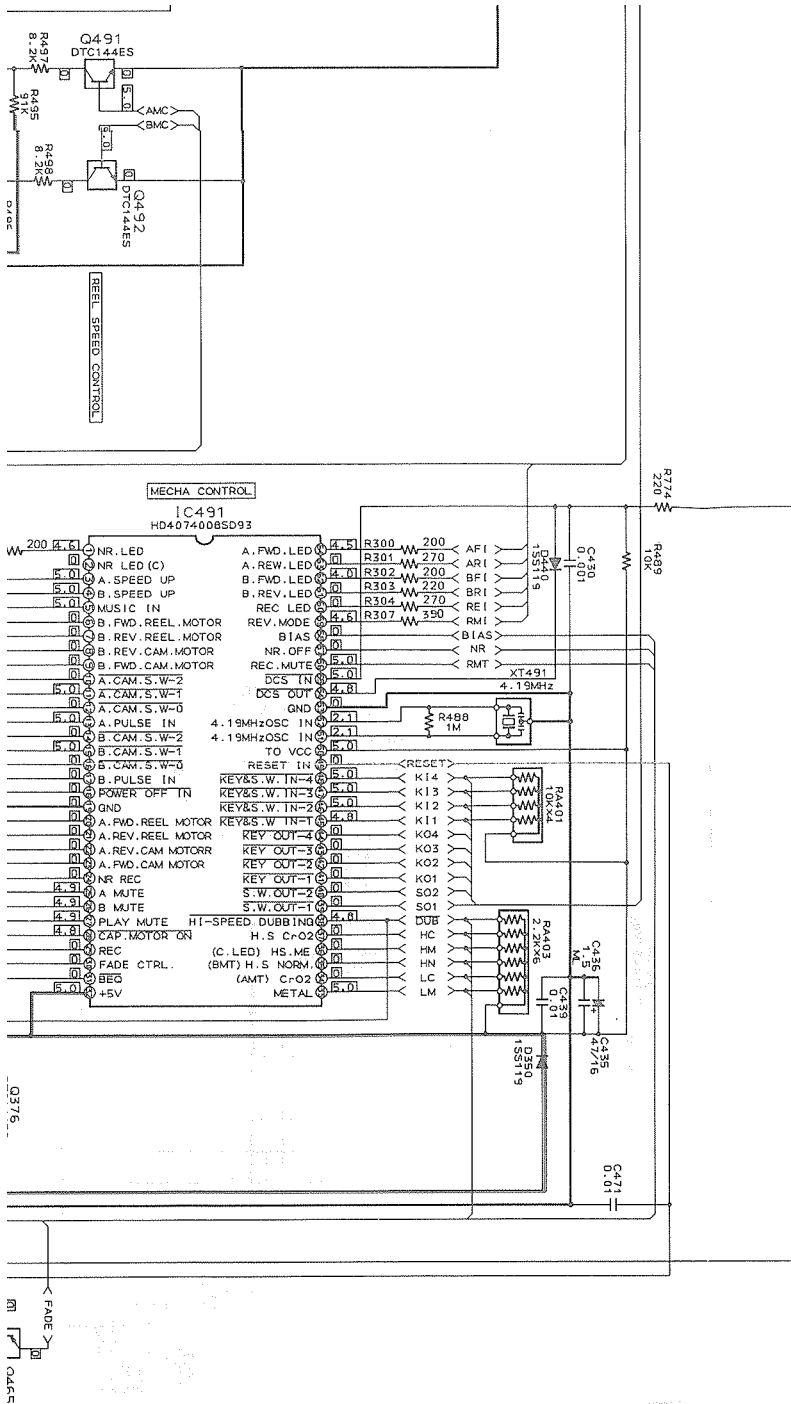

Printed Circuit Boards

(1) Main, Deck & Amplifier CB (ENH-238)

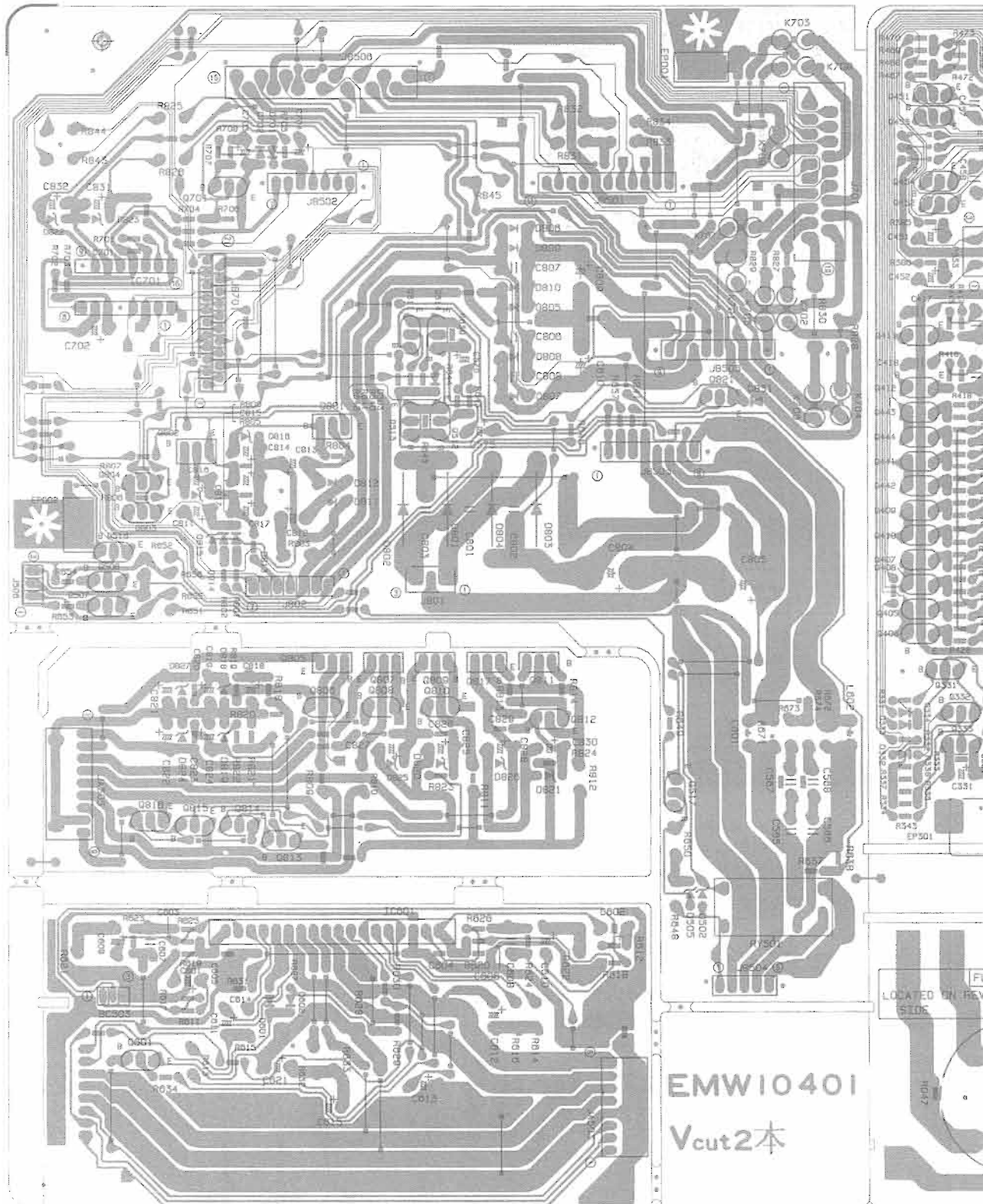

(2) Select, System & Deck Control CB (ENB-179)

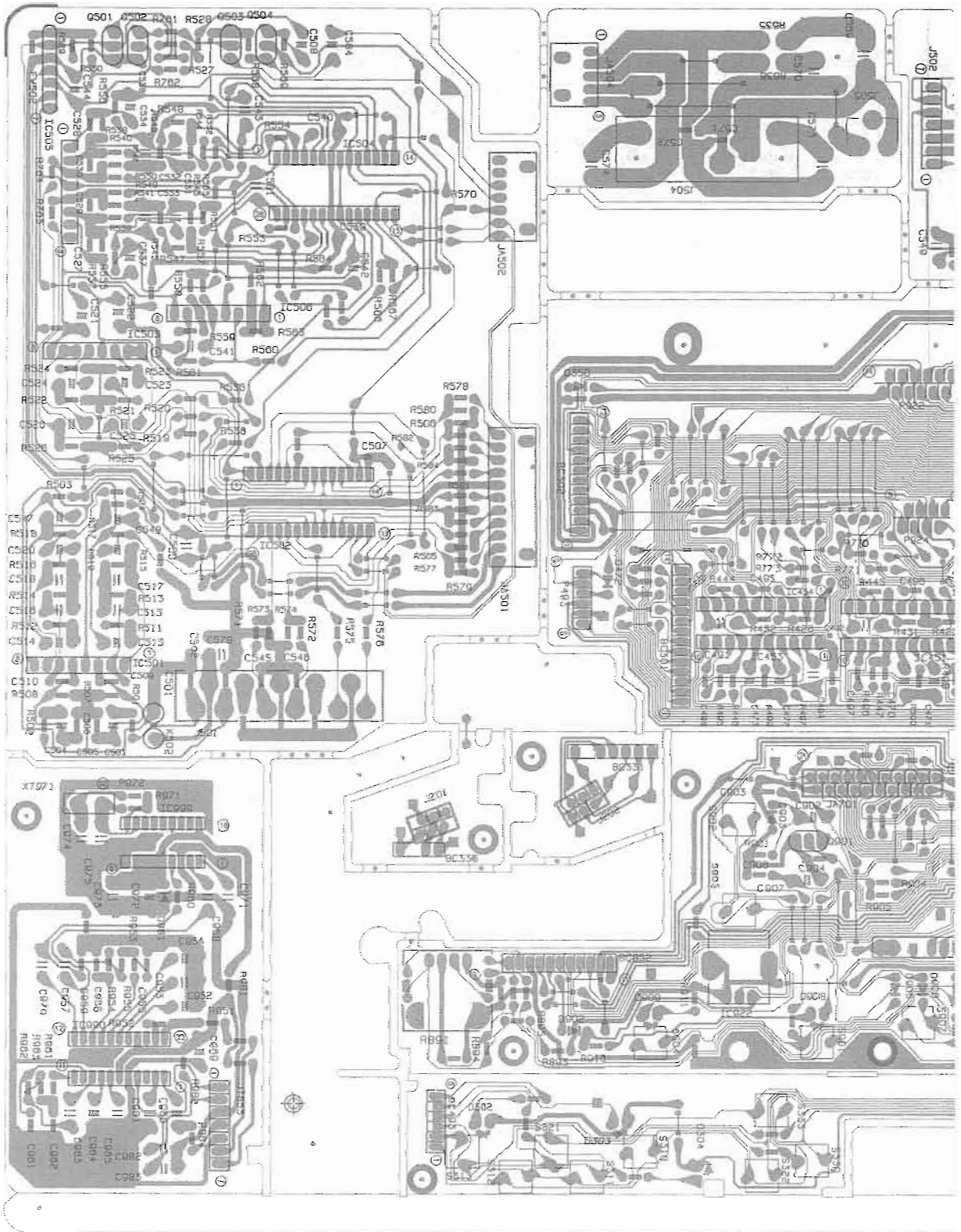

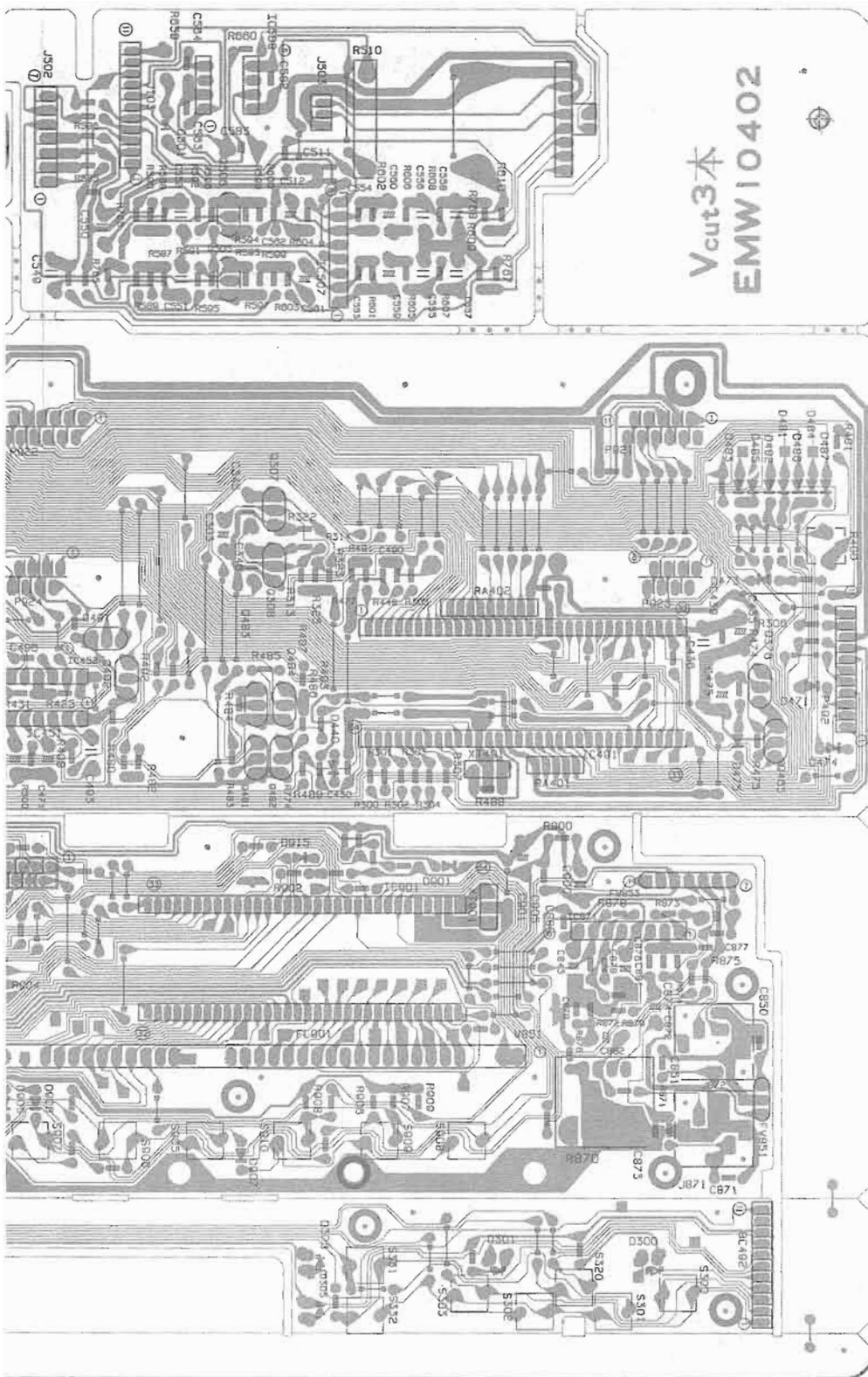

Block Diagrams

(1) System

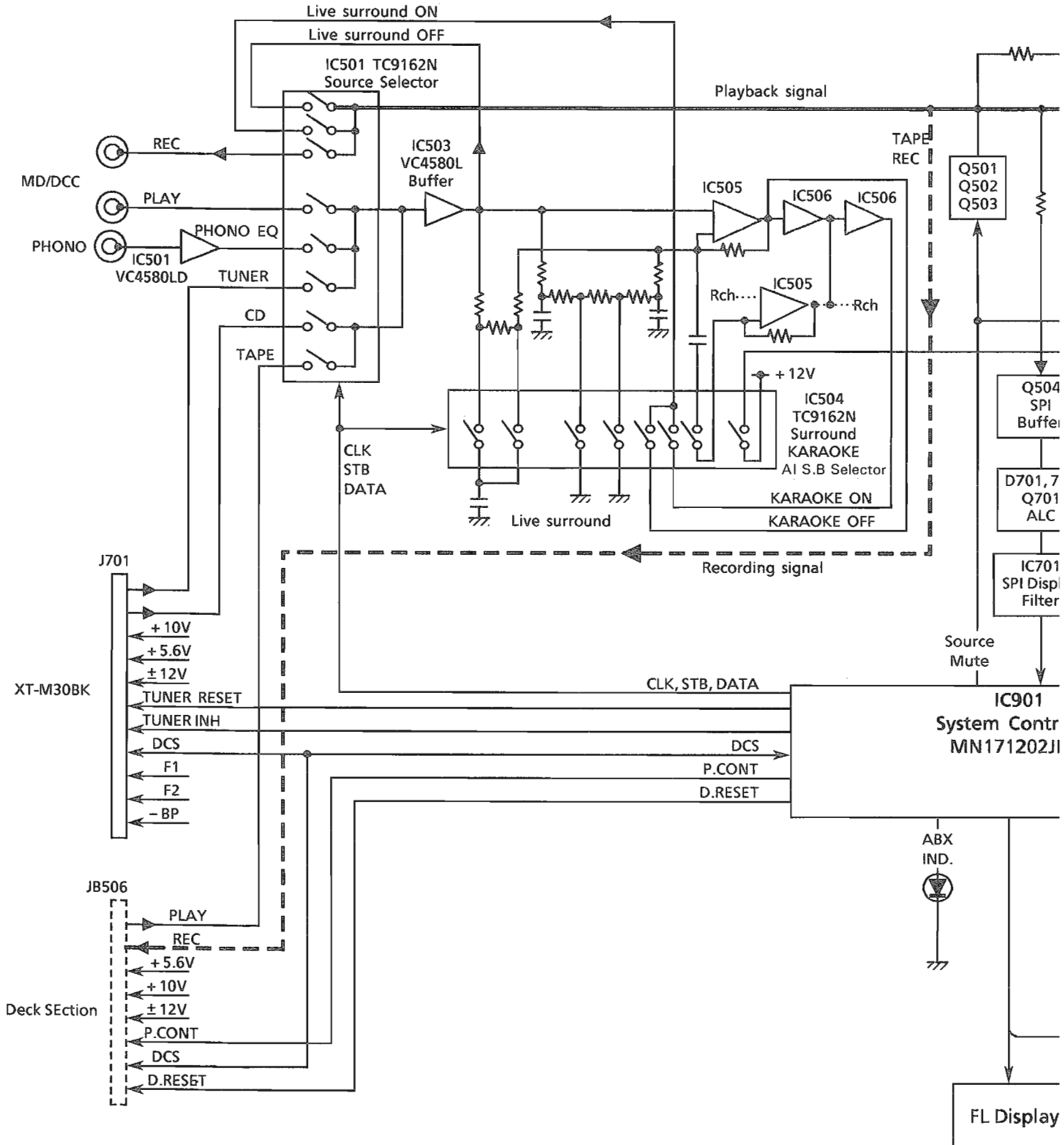

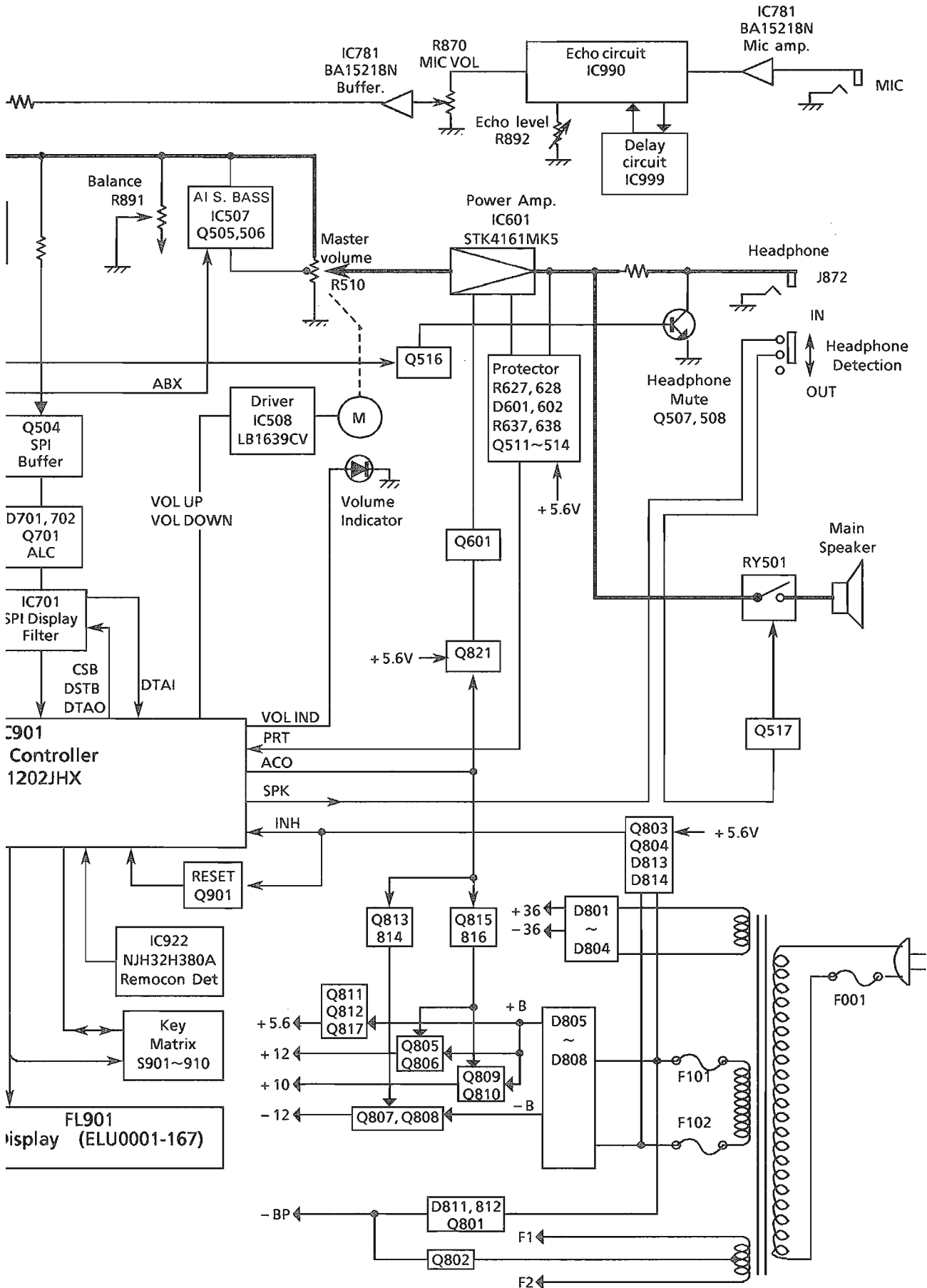

(2) Cassette Deck

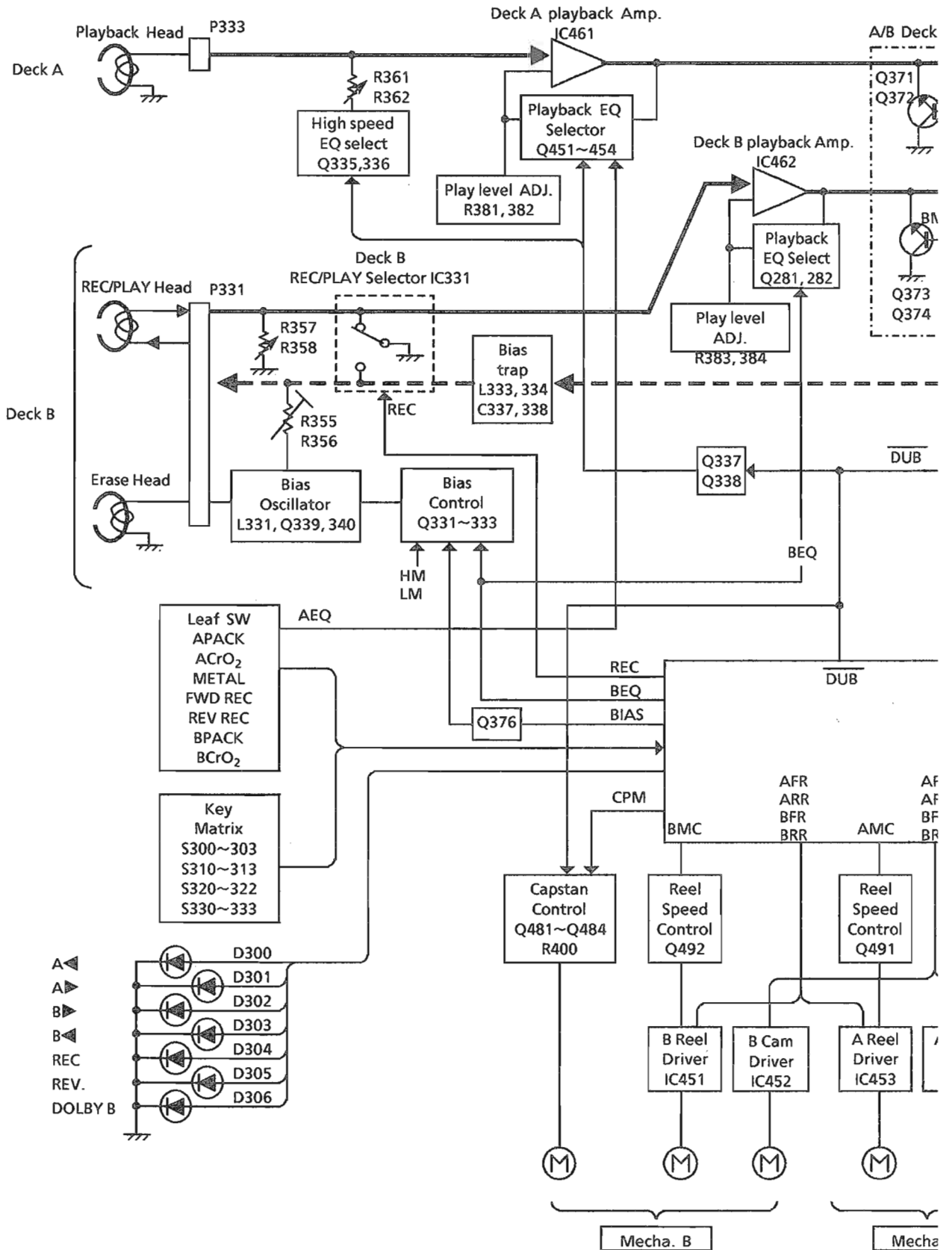

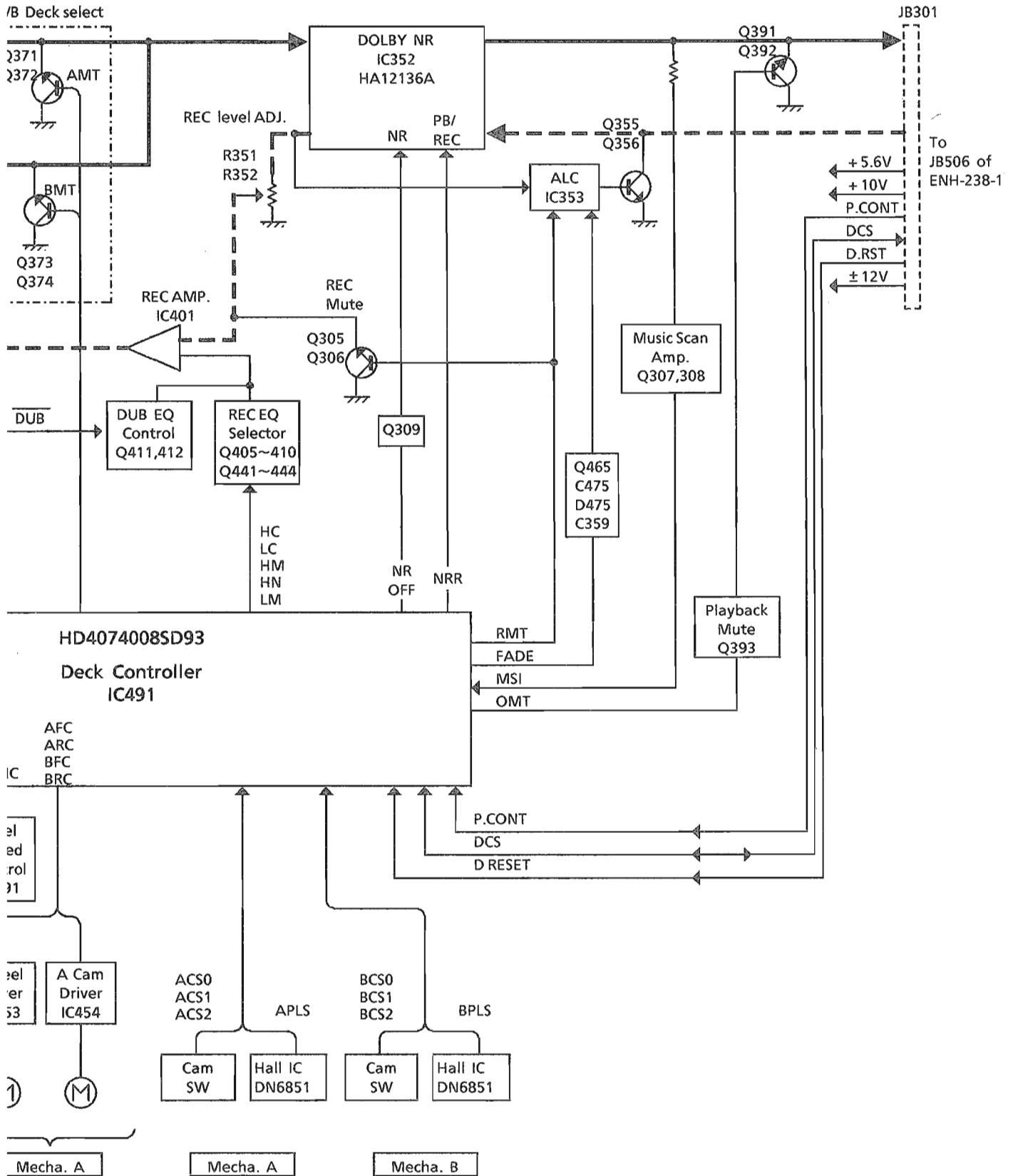

XT-M30BK

— Contents—

Description of Major LSIs	43
Internal Connections of FL Display	55
Disassembly Procedures	57
Adjustment Procedures	60
Maintenance of Laser Pickup	61
Replacement of Laser Pickup	61
Flow of Functional Operation Until TOC is Read	62
Operation check by each switch	63
Initial Operation of Mechanism	64
Troubleshooting	66
Block Diagram	71
Schematic Diagrams	73
Printed Circuit Boards	75

Description of Major LSIs

■ MN173212JHR (IC201) : TUNER SYSTEM CONTROLLER

1. Terminal Layout

63 ~ 43	
64	42
}	}
84	22
1 ~ 21	

2. Key Matrix

	KEY IN 0	KEY IN 1	KEY IN 2	KEY IN 3
KEY OUT 0	—	DALY	REC	MEMORY
KEY OUT 1	SLEEP	CLOCK ADJ	SOURCE/ REC TIME	HOUR
KEY OUT 2	UP	DOWN	PRESET UP	PRESET DOWN
KEY OUT 3	FM	AM	MINUTE	VOLUME POSITION

3. Description

Pin No.	symbol	I/O	Description	Pin No.	symbol	I/O	Description
1	12G	O	FL grid control output	43	DATA OUT	O	Data for PLL synthesizer
2	11G	O	⋄	44	f out	O	Clock frequency
3		—	Not used	45		—	Not used
4	S48	O	FL segment control output	46		—	⋄
5	S47	O	⋄	47		—	⋄
6	S46	O	⋄	48	/INH	I	Inhibit signal for tuner controller
7	S45	O	⋄	49		—	Not used
8	S44	O	⋄	50	/TUNED	I	For the indication "TUNED"
9	S43	O	⋄	51	/STEREO	I	For the indication "STEREO"
10	S42	O	⋄	52	MUTE	O	Muting tuner sound
11	S41	O	⋄	53		—	Not used
12	S40	O	⋄	54	/DCS OUT	O	Compulink signal output
13	S39	O	⋄	55	/DCS IN	I	Compulink signal input
14	S38	O	⋄	56	KIN 0	I	Key matrix input
15	S37	O	⋄	57	KIN 1	I	⋄
16	S36	O	⋄	58	KIN 2	I	⋄
17	S35	O	⋄	59	KIN 3	I	⋄
18	S34	O	⋄	60	KOUT 0	O	Key matrix output
19	S33	O	⋄	61	KOUT 1	O	⋄
20	S32	O	⋄	62	KOUT 2	O	⋄
21	S31	O	⋄	63	KOUT 3	O	⋄
22	S30	O	⋄	64	KOUT 4	O	⋄
23	— 30	—	Power supply for FL display	65	KOUT 5	O	⋄
24	S29	O	FL segment control output	66	KOUT 6	O	⋄
25	S28	O	⋄	67	KOUT 7	O	⋄
26	S27	O	⋄	68	/RST	I	Reset signal input
27	S26	O	⋄	69	X1	—	Connected to GND
28	S25	O	⋄	70	X2	—	Not used
29	S24	O	⋄	71	VSS	—	Connected to GND
30	S23	O	⋄	72	OSC2	I/O	Clock oscillation terminal
31	S22	O	⋄	73	OSC1	I/O	Clock oscillation terminal
32	S21	O	⋄	74	VDD	—	Power supply
33	S20	O	⋄	75	JAPAN/U	I	L:JAPAN, H:U
34	S19	O	⋄	76	TEST	—	Test mode terminal
35	S18	O	⋄	77	20G	O	FL grid control output
36	S17	O	⋄	78	19G	O	⋄
37	S16	O	⋄	79	18G	O	⋄
38	S15	O	⋄	80	17G	O	⋄
39	S14	O	⋄	81	16G	O	⋄
40	CE	O	Chip enable signal for PLL synthesizer	82	15G	O	⋄
41	CLK	O	Clock for PLL synthesizer	83	14G	O	⋄
42	DATA IN	I	Data from PLL synthesizer	84	13G	O	⋄

■ MN172412JHSI (IC970) : CD SYSTEM CONTROLLER

1. Terminal Layout

42	~	22
43		21
}		}
63		1
64	~	84

2. Key Matrix

	KEY IN 0	KEY IN 1	KEY IN 2	KEY IN 3
1G	1	2	3	4
2G	5	6	7	8
3G	9	10	+10	—
4G	FD OPEN/CLOSE	D5	D6	—
5G	EDIT	INTRO	CALL	P.MODE
6G	+1 TIME ►►	+10 TIME ◄◄	SIDE A/B	■/CANCEL
7G	D1	D2	P1	►/
9G	D4	EJECT	P1 OPEN/CLOSE	D3

3. Description

Pin No.	symbol	I/O	Description	Pin No.	symbol	I/O	Description
1	3G	O	FL grid control output	43	MDATA	O	μ-com command data output
2	4G	O	◇	44	P.OFF	O	H : power off, L : power on.
3	5G	O	◇	45	SQCK	O	80-bit Sub Q and 16-bit PCM Peak Level Data
4	6G	O	◇	46	SUBQ	I	Sub-code Q-code input
5	7G	O	◇	47	MLD	O	μ-com command load signal output
6	8G	O	◇	48	STATUS	I	Status signal input
7	9G	O	◇	49	/TLOCK	I	Lock signal for Tracking
8	10G	O	◇	50	/FLOCK	I	Lock signal for Focus
9	DGT12	—	Connected to GND	51	TCIA	—	Connected to GND
10	DGT13	I	/TEST	52	IRQ2	—	◇
11	KEY IN0	I	Key matrix input	53	TUNER INH	O	Inhibitsignal for tuner controller
12	KEY IN1	I	◇	54	TBLO	—	Connected to GND
13	KEY IN2	I	◇	55	DCS IN	I	Compulink signal input
14	KEY IN3	I	◇	56	DCS OUT	O	Compulink signal output
15	PLAY LED	O	PLAY indicator signal output	57	OPEN/LOAD	O	P1 Open or Load
16	P1 LED	O	P1 indicator signal output	58	CLOSE/UNLOAD	O	P1 Close or Unload driving control signal
17	D1 LED	O	DISC1 indicator signal output	59	SD	O	Load drive speed down output
18	D2 LED	O	DISC2 indicator signal output	60	/PU REST	I	Pick up rest switch input
19	D3 LED	O	DISC3 indicator signal output	61	/LOAD SW	I	Disc load detect signal
20	D4 LED	O	DISC4 indicator signal output	62	/JAB SW	I	JAB switch signal
21	D5 LED	O	DISC5 indicator signal output	63	/MAG IN SW	I	Magazine in signal
22	D6 LED	O	DISC6 indicator signal output	64	UP	O	Lifter driving control signal
23	- VDISP	—	Power supply for FL display	65	DOWN	O	Lifter driving control signal
24	S1	O	FL segment control output	66	FD OPEN	O	Front door open driving control signal
25	S2	O	◇	67	FD CLOSE	O	Front door close driving control signal
26	S3	O	◇	68	RESET	I	Reset signal input
27	S4	O	◇	69	X1	—	Connected to GND
28	S5	O	◇	70	X2	—	Not used
29	S6	O	◇	71	VSS	—	GND
30	S7	O	◇	72	OSC2	O	Clock oscillation output
31	S8	O	◇	73	OSC1	I	Clock oscillation input
32	S9	O	◇	74	VDD	—	Power supply
33	S10	O	◇	75	/UP/DOWN SW	I	Height detect signal
34	S11	O	◇	76	/R&M SW	I	Reset & Memory switch input
35	S12	O	◇	77	/CLOSE SW	I	"L" with tray closed
36	S13	O	◇	78	/OPEN SW	I	"L" with tray opened
37	MS0	I	Mode select	79	/FD CLOSE SW	I	"L" with Front Door closed
38	MS1	I	Mode select	80	/FD OPEN SW	I	"L" with Front Door opened
39	SED15	—	Connected to GND	81	DGT25	—	Connected to GND
40	/RST	O	System Reset signal output	82	DGT24	—	◇
41	MCLK	O	μ-com command clock signal output	83	1G	O	FL grid control output
42	SENSE	I	SENSE signal input	84	2G	O	◇

■ MN35502(IC920) : D / A CONVERTER

1. Terminal Layout

DIN	1	28	RSBDN
LRCK	2	27	RSBUP
BCK	3	26	M3
M4	4	25	DVDD1
DVDD2	5	24	XIN
CKO	6	23	XOUT
DVSS2	7	22	DVSS1
M1	8	21	M2
OUT1C	9	20	OUT2C
OUT1B	10	19	OUT2B
AVDD1	11	18	AVDD2
OUT1D	12	17	OUT2D
OUT1A	13	16	OUT2A
AVSS1	14	15	AVSS2

2. Block Diagram

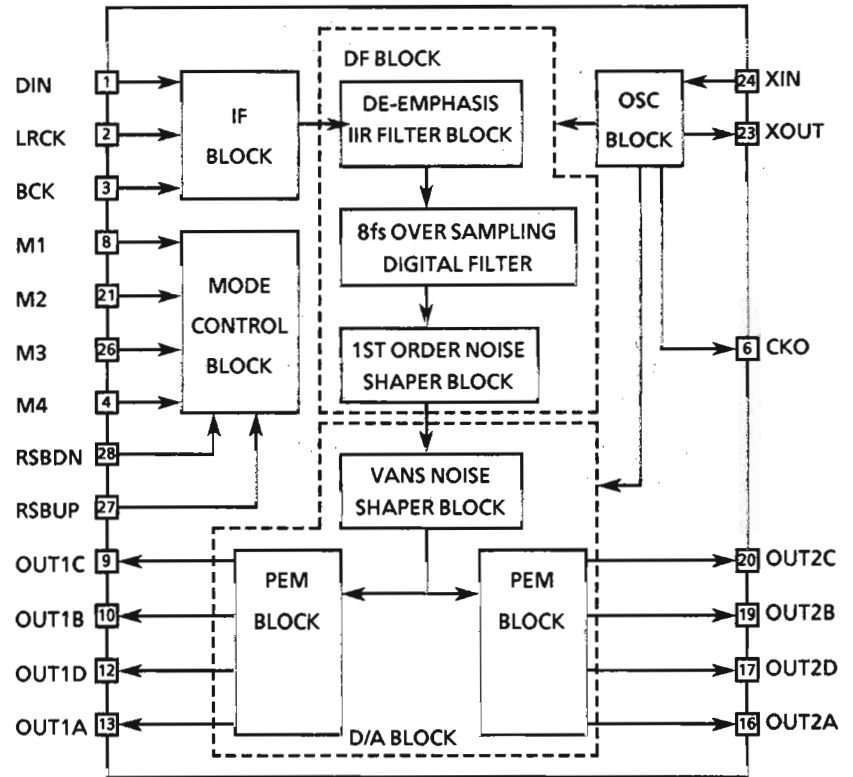

3. Description

Pin No	Symbol	I/O	Description	Pin No	Symbol	I/O	Description
1	DIN	I	Data input	15	AVSS2	--	Analog ground 2
2	LRCK	I	LR clock input	16	OUT2A	O	2A PEM output
3	BCK	I	Bit clock input	17	OUT2D	O	2D PEM output
4	M4	I	Operational mode control 4	18	AVDD2	--	Analog power supply 2
5	DVDD2	--	Digital power supply 2	19	OUT2B	O	2B PEM output
6	CKO	I	Clock output	20	OUT2C	O	2C PEM output
7	DVSS2	--	Digital ground 2	21	M2	--	Connected to ground
8	M1	--	Connected to ground	22	DVSS1	--	Digital ground pin 1
9	OUT1C	O	1C PEM output	23	XOUT	O	Crystal oscillator output
10	OUT1B	O	1B PEM output	24	XIN	I	Crystal oscillator input
11	AVDD1	--	Analog power supply 1	25	DVDD1	--	Digital power supply 1
12	OUT1D	O	1D PEM output	26	M3	--	Connected to ground
13	OUT1A	O	1A PEM output	27	RSBUP	--	Connected to ground
14	AVSS1	--	Analog ground 1	28	RSBDN	I	Reset signal / Digital Att. control signal input

■ AN8803SB (IC830) : RF & SERVO AMP

1. Terminal Layout

PD	1	36 PDAC
LD	2	35 PDBD
LDON	3	34 PDE
LDP	4	33 PDF
VCC	5	32 PDER
RF-	6	31 PDFR
RF OUT	7	30 TBAL
RF IN	8	29 FBAL
C.AGC	9	28 FE-
ARF	10	27 FE OUT
C.ENV	11	26 TE-
C.EA	12	25 TE OUT
CS BDO	13	24 CROSS
BDO	14	23 TE BPF
CS BRT	15	22 VDET
OFTR	16	21 LD OFF
/NRFDET	17	20 VREF
GND	18	19 ENV

2. Block Diagram

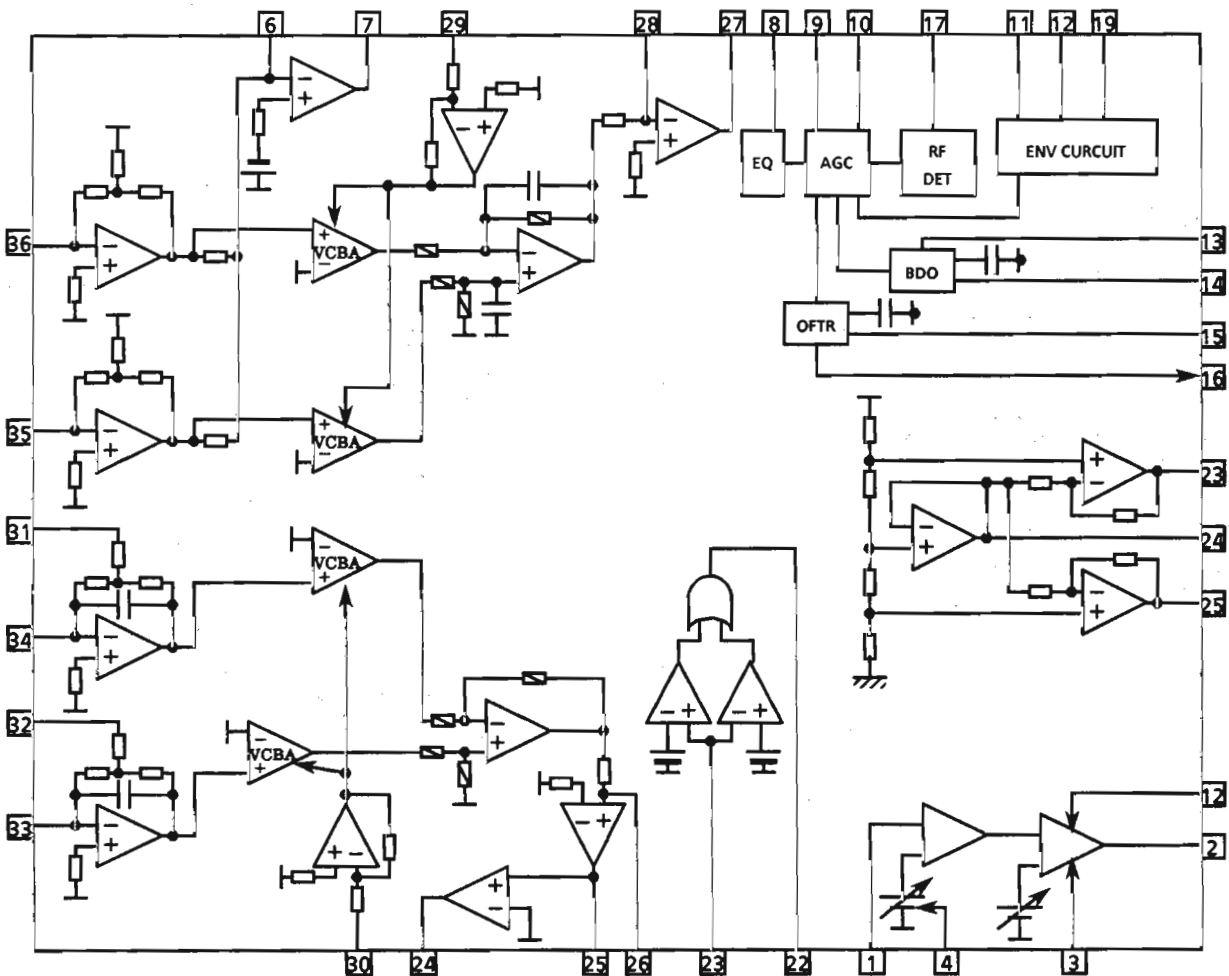

3. Description

Pin No.	Symbol	I/O	Description
1	PD	--	Connected to GND
2	LD	--	Non connection
3	LD ON	--	Connected to GND
4	LDP	--	Connected to GND
5	VCC	--	Power supply
6	RF-	I	Inverse input pin for RF amp
7	RF OUT	O	RF amp output pin
8	RF IN	I	AGC input pin
9	C.AGC	I/O	Connecting pin of AGC loop filter
10	ARF	O	AGC output pin
11	C.ENV	I/O	A capacitor is connected to this terminal to detect the envelope of RF signal
12	C.EA	I/O	A capacitor is connected to this terminal to detect the envelope of RF signal
13	CS BDO	I/O	A capacitor is connected to detect the lower envelope of the RF signal
14	BDO	O	BDO output pin
15	CS BRT	I/O	A capacitor is connected to detect the lower envelope of the RF signal
16	OFTR	O	Of-track status signal output pin
17	/NRFDDET	O	RF detection signal output pin
18	GND	--	GND
19	ENV	O	Envelope output
20	VREF	O	Reference voltage output pin
21	LD OFF	--	Connect to GND
22	VDET	O	Vibration detection signal output pin
23	TE BPF	I	Input pin of tracking error through BPF
24	CROSS	O	Tracking error cross output pin
25	TE OUT	O	Tracking error signal output pin
26	TE-	I	Inverse input pin for tracking error amp
27	FE OUT	O	Output pin of focus error
28	FE-	I	Inverse input pin for focus error amp
29	FBAL	I	Focus balance control pin
30	TBAL	I	Tracking balance control pin
31	PDFR	I/O	E and E I-V amp gain control pin
32	PDER	I/O	F and E I-V amp gain control pin
33	PDF	I	I-V amp input pin
34	PDE	I	I-V amp input pin
35	PD BD	I	I-V amp input pin
36	PD AC	I	I-V amp input pin

■ MN662720RB (IC810) : DIGITAL SERVO & DIGITAL SIGNAL PROCESSER

1. Terminal Layout

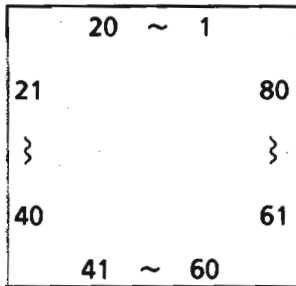

2. Block Diagram

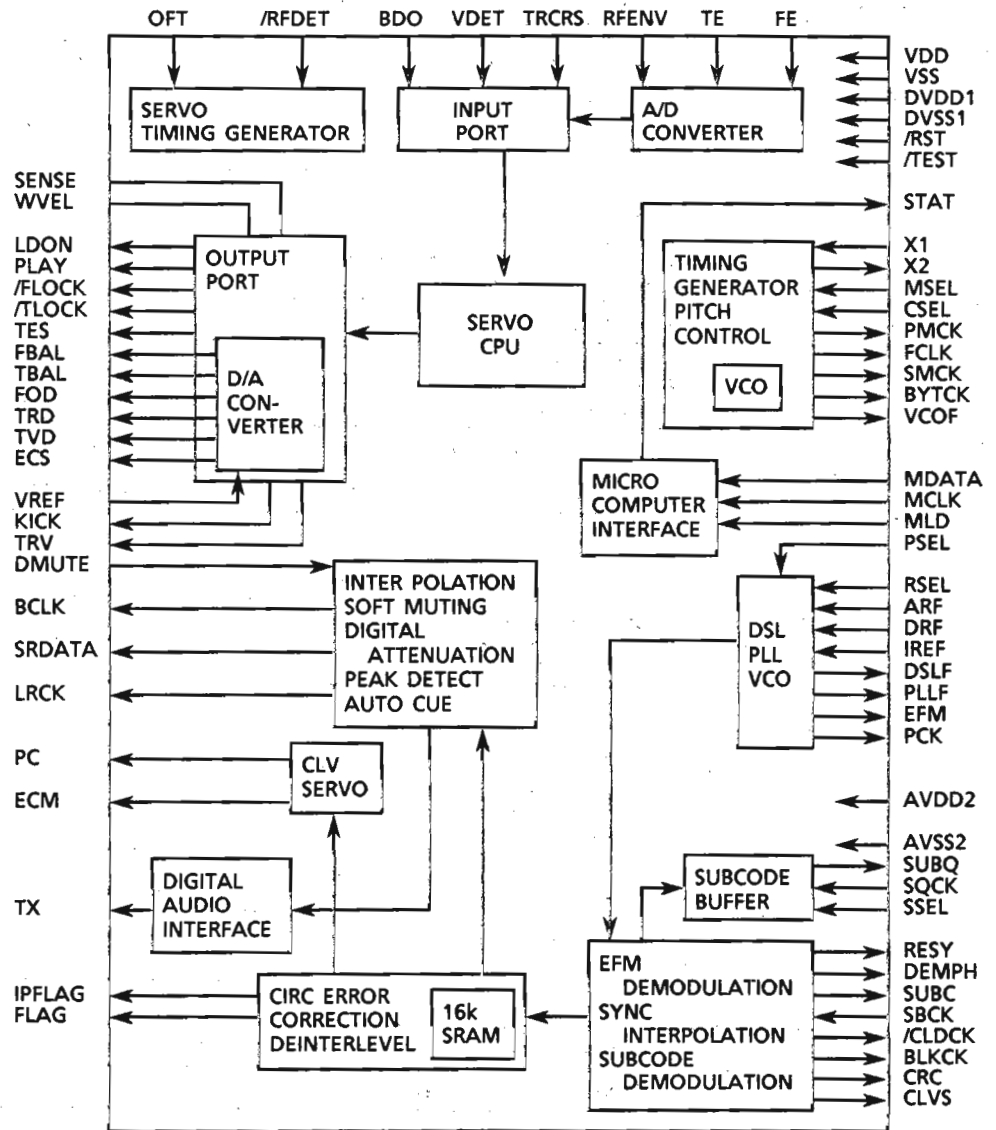

3. Description

Pin No.	symbol	I/O	Description	Pin No.	symbol	I/O	Description
1	BCLK	O	Bit clock output pin for SRDATA	41	TES	—	Not used
2	LRCK	O	L/R distinction signal	42	PLAY	—	⌀
3	SRDATA	O	Serial data output	43	WVEL	—	⌀
4	DVDD1	—	Power supply	44	ARF	I	RF signal input
5	DVSS1	—	Connected to GND	45	IREF	I	Reference current input pin
6	TX	O	Digital audio interface signal	46	DRF	I	Bias adjustment pin for DSL
7	MCLK	I	μ-com command clock signal input	47	DSLIF	I/O	Loop filter pin for DSL
8	MDATA	I	μ-com command data input	48	PLLIF	I/O	Loop filter pin for PLL
9	MLD	I	μ-com command load signal input	49	VCOF	—	Not used
10	SENSE	O	Sense signal output	50	AVDD2	—	Power supply
11	FLOCK	O	Lock signal for Tracking	51	AVSS2	—	Connected to GND
12	TLOCK	O	Lock signal for Focus	52	EFM	—	Not used
13	BLKCK	—	Not used	53	PCK	—	⌀
14	SQCK	I	Clock for sub-code Q resister	54	PDO	—	⌀
15	SUBQ	O	Sub-code Q-code output	55	SUBC	—	⌀
16	DMUTE	I	Muting input (H : MUTE)	56	SBCK	—	Connected to GND
17	STATUS	O	Status signal	57	VSS	—	⌀
18	/RST	I	Reset signal input (L:Reset)	58	X1	I	Input of 16.9344MHz X'tal oscillation circuit
19	SMCK	—	Not used	59	X2	—	Not used
20	PMCK	—	Not used	60	VDD	—	Power supply
21	TRV	O	Traverse enforced output	61	BYTCK	—	Not used
22	TVD	O	Traverse drive output	62	CLDCK	—	⌀
23	PC	—	Not used	63	FCLK	—	⌀
24	ECM	O	Spindle motor drive signal (Enforced output) 3-State	64	IPPLAG	—	⌀
25	ECS	O	Spindle motor drive signal (Servo signal)	65	FLAG	—	⌀
26	KICK	O	Kick pulse output	66	CLVS	—	⌀
27	TRD	O	Tracking drive output	67	CRC	—	⌀
28	FOD	O	Focus drive output	68	DEMPH	O	De-emphasis ON signal (H : ON)
29	VREF	I	Reference voltage input pin	69	RESY	—	Not used
30	FBAL	O	Focus Balance adjust signal output	70	RST 2	—	Connected to GND
31	TBAL	O	Tracking Balance adjust signal output	71	/TEST	—	Pull up (+5V)
32	FE	I	Focus error signal input	72	AVDD1	—	Power supply
33	TE	I	Tracking error signal input	73	OUT L	—	Not used
34	RF ENV	I	RF envelope signal input	74	AVSS1	—	Connected to GND
35	VDET	I	Vibration detect signal input	75	OUT R	—	Not used
36	OFT	I	Off track signal input	76	RSEL	—	Pull up (+5V)
37	TRCRS	I	Track cross signal input	77	CSEL	—	Connected to GND
38	/RFDET	I	RF detect signal input	78	PSEL	—	⌀
39	BDO	I	BDO input pin	79	MSEL	—	⌀
40	LDON	O	Laser ON signal output	80	SSEL	—	Pull up (+5V)

■ LA1266A (IC104) : FM AM IF AMP & detector

1. The main function descriptions

- (1) Amplify and detect of FM intermodulation frequencies.
- (2) It has local oscillator and mixer for AM, and amplify the AM-IF signal.

2. Top View

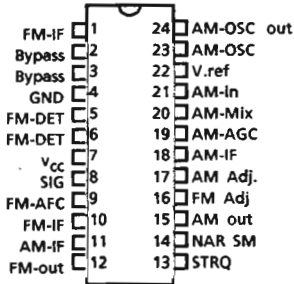

3. Block Diagram

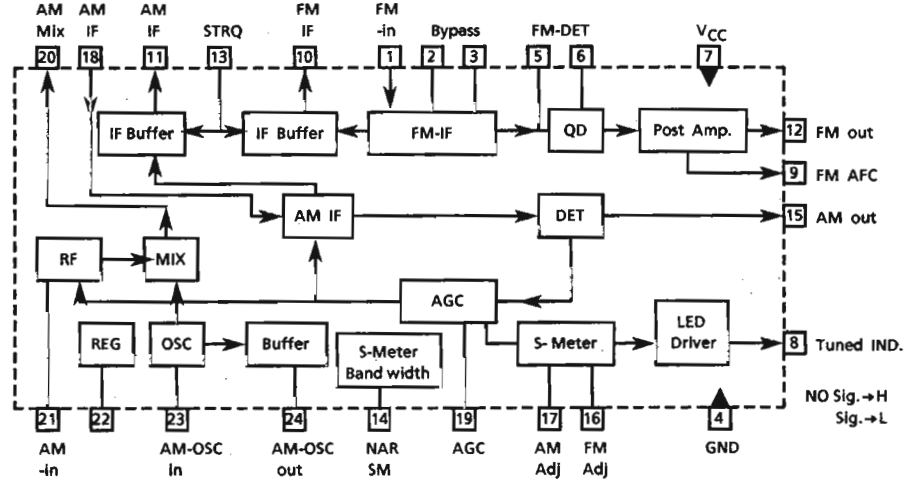

4. Description

Pin No.	Symbol	I/O	Description
1	FM IF	I	This is an input terminal of FM IF Signal.
2, 3	Bypass	---	Bypass of FM IF Amp.
4	GND	---	This is the device ground terminal.
5, 6	FM DET	---	FM detect transformer.
7	V _{CC}	---	This is the power supply terminal.
8	SIGNAL	O	Mute drive and signal stop drive output when tuning. Active Low
9	FM AFC	O	This is an output terminal of voltage for FM-AFC.
10	FM IF	O	When the IF REQ signal of IC251(LC7218) applies to pin13, the signal of FM IF outputs.
11	AM IF	O	When the IF REQ signal of IC251(LC7218) applies to pin13, the signal of AM IF outputs.
12	FM out	O	FM detection output.
13	STRQ	I	The IF-signals come out from pin10 (FM-IF) or pin11 (AM-IF) while this terminal goes to "High".
14	NAR SM	---	Control the Band-width of AM signal meter.
15	AM out	O	AM detection output.
16	FM Adj	---	For adjust the stop level (or mute level) of FM.
17	AM Adj	---	For adjust the stop level (or mute level) of AM.
18	AM-IF	I	Input of AM IF Signal.
19	AM-AGC	I	This is an AGC voltage Input terminal for AM.
20	AM-MIX	O	This is an output terminal for AM mixer.
21	AM-IN	I	This is an input terminal for AM RF Signal.
22	V.REF	---	Control the Band-width of FM signal meter.
23	AM-OSC	---	This is a terminal of AM Local oscillation circuit.
24	AM-OSC out	O	AM Local Oscillation Signal output.

■ LA3401 (IC105) : FM MPX Detector

1. The main function descriptions

- (1) Detect the FM Multiplex Signal (Stereo signal).
- (2) When receiving FM Stereo Signal, it outputs the signal for indicator.
- (3) AM/FM Audio Amplifier.

(1) Terminal Layout

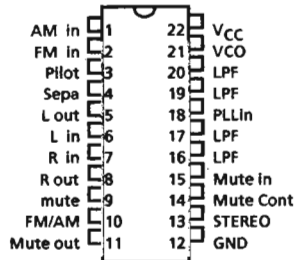

2. Block Diagram

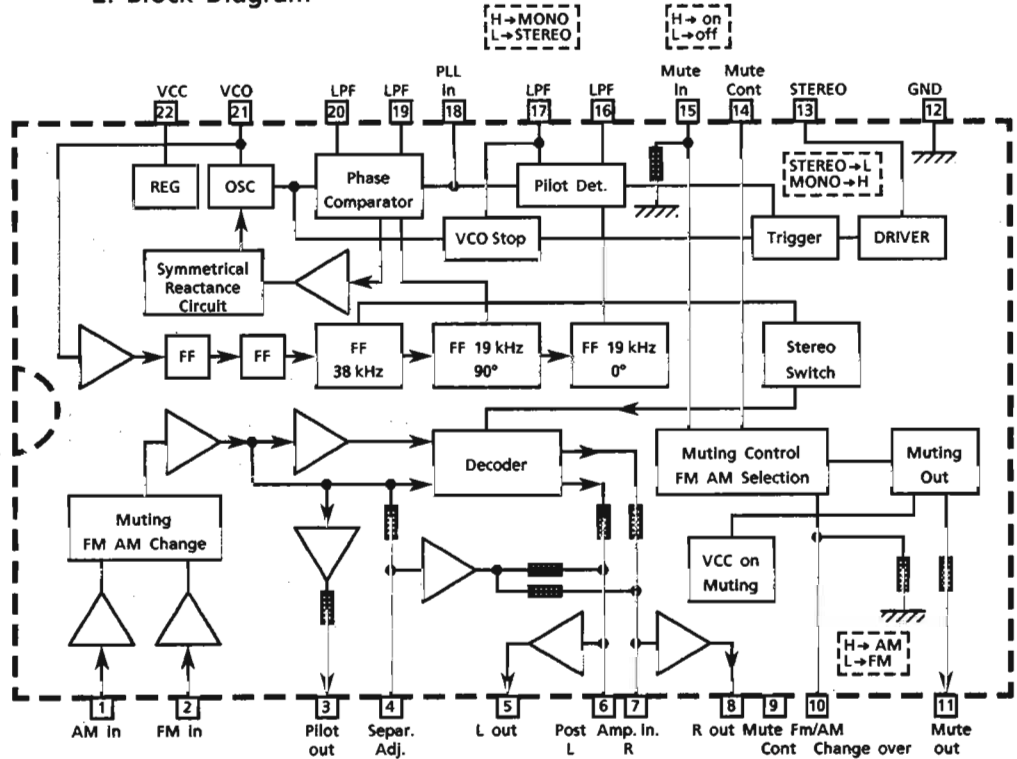

3. Description

Pin No.	Symbol	I/O	Description
1	AM in	I	This is an input terminal for AM detection signal.
2	FM in	I	This is an input terminal for FM detection signal.
3	Pilot out	O	Output of MPX pilot signal (Connect to Pin18).
4	Sepa. Adj.	---	Separation adjustment.
5	L. out	O	Left channel signal output.
6	L	O	Reversal output of Pin5.
7	R	O	Reversal output of Pin8.
8	R out	O	Right channel signal output
9	Mute Cont	---	The mute time is controlled by the connected capacitor when turning the power switch on.
10	FM / AM	I	Change over the FM / AM input. "H" : AM, "L" : FM
11	Mute out	---	Not use
12	GND	---	Ground terminal.
13	Stereo	O	Stereo indicator output. Stereo : "L", Mono : "H"
14	Mute Cont	---	The mute time is controlled by the connected capacitor when changing over the FM / AM .
15	Mute in	I	Mute signal input. "H" : Mute on, "L" : Mute off.
16	LPF	---	Low pass filter of pilot detector.
17	LPF	---	While this terminal goes to "H", the VCO stop.
18	Pilot in	I	PLL input.
19	LPF	---	Low-pass filter of PLL.
20	LPF	---	Low-pass filter of PLL.
21	VCO	I	Voltage controlled oscillator terminal.
22	Vcc	---	Power supply.

■ LC7218 (IC102) : PLL Synthesizer

1. The main function descriptions

- (1) It makes the local oscillation frequency by the control data from IC901.
- (2) Decode the control signal and transmit the signal for receiving conditions.
- (3) For the best tuning, count the internal-frequency and transmit the data to IC901.

2. Terminal Layout

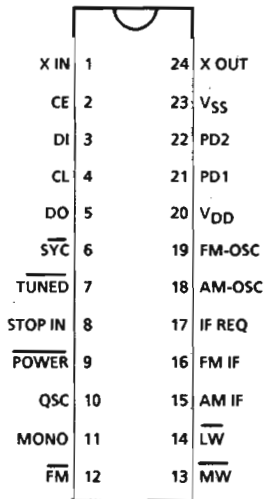

3. Block Diagram

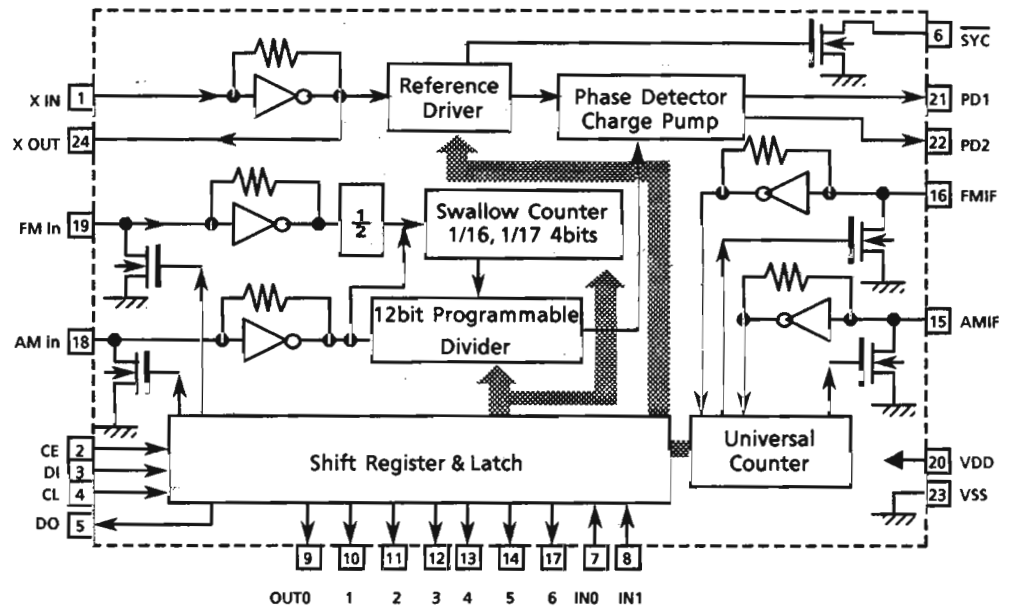

4. Description

Pin No.	Symbol	I/O	Description
1,24	X in , X out	I/O	Crystal oscillator (7.2MHz).
2	CE	I	Fix the chip enable to "H" when inputting (DI) and outputting (DO) the serial data.
3	DI	I	Receive the control data from the controller (IC801).
4	CL	I	This clock is used to synchronize data when transmitting the data of DI and DO.
5	DO	O	Transmit the data from LC7218 to the controller which is synchronized with CL.
6	SYC	-	Not used.
7	TUNED	I	Receive the tuned signal from IC104 (LA1266A).
8	STOP IN	-	Connected to GND
9	POWER	-	Not used.
10	QSC	-	Not used.
11	MONO	O	It is "H" on FM-monaural, "L" on FM-Stereo.
12	FM	O	It is "L" on FM mode.
13	MW	O	It is "L" on MW mode.
14	LW	O	It is "L" on LW mode.
15	AM-IF	I	Universal counter input for AM-IF from IC104 (LA1266A).
16	FM-IF	I	Universal counter input for FM-IF from IC104(LA1266A).
17	IF REQ	O	Output the "IF-signal request" to IC104 when the pin-7 (tuned in) goes to "H".
18	AM OSC	I	Input the local oscillator signal of AM.
19	FM OSC	I	Input the local oscillator signal of FM.
20	V _{DD}	-	This is a terminal of power supply.
21	PD1	O	PLL charge pump output : When the local oscillator signal frequency is higher than the reference frequency high level signals will output. When it is lower than the reference frequency, low level signals will output. When it is same as reference frequency signals, it will be floating.
22	PD2	-	Not used.
23	V _{SS}	-	Connected to GND

■ TA8124P (IC101) : Stereo Decoder

1. Block Diagram

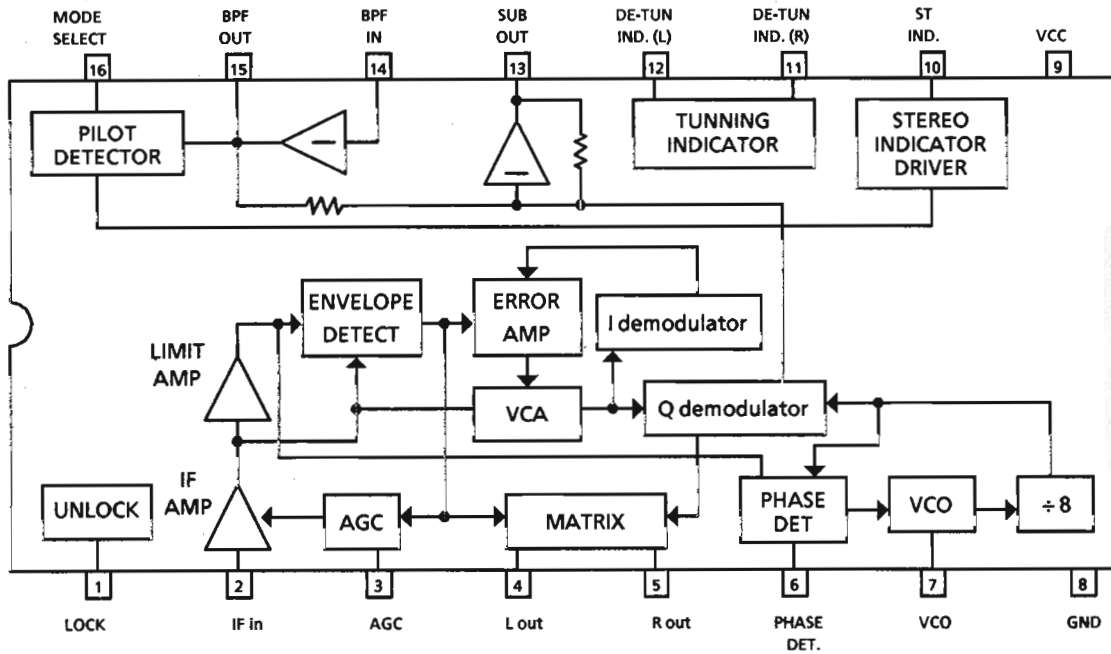

2. Description

Pin No.	Symbol	I/O	Description
1	LOCK	-	Terminal for lock detect
2	IF in	I	Input terminal of AM IF signal
3	AGC	-	Terminal to the automatic gain controller
4	L out	O	Audio signal output
5	R out	O	Audio signal output
6	PHASE DET.	O	Phase detector
7	VCO	-	Voltage controlled oscillator terminal
8	GND	-	GND
9	VCC	-	VCC
10	ST IND.	-	Insication control signal for "STEREO"
11	DE-TUN IND. (H)	-	Not used
12	DE-TUN IND. (L)	-	Not used
13	SUB out	O	SUB signal output
14	BPF in	I	Input terminal to the low pass filter
15	BPF out	O	Low pass filter output
16	MODE SELECT	I	Monanral contro signal input

■ BA6393FP(IC860) : BTL DRIVER

1. Terminal Layout

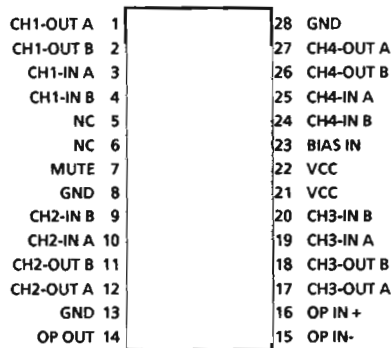

2. Block Diagram

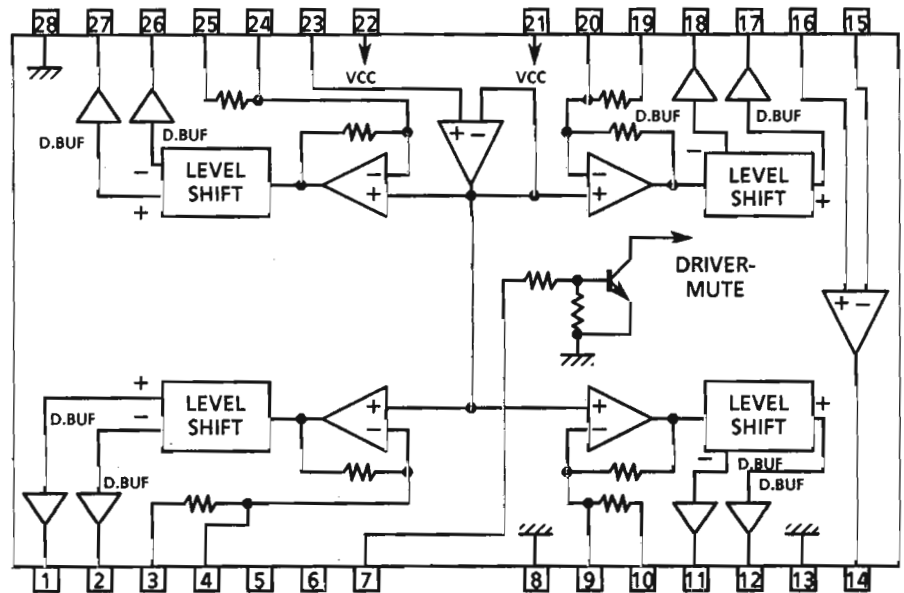

3. Description

Pin No.	Symbol	I/O	Description
1	CH1-OUT A	O	Focus drive output
2	CH1-OUT B	O	
3	CH1-IN A	I	Focus drive input
4	CH1-IN B	-	Non connection
5,6	NC		
10	CH2-IN A		
19	CH3-IN A		
24	CH4-IN B	I	Tracking drive input
7	MUTE	I	Mute signal input pin
9	CH2-IN B	I	Spindle motor drive input
20	CH3-IN B	I	Feed motor drive input

Pin No.	Symbol	I/O	Description
8,13,28	GND	-	GND
11	CH2-OUT B	O	Spindle motor drive output
12	CH2-OUT A	O	OP amp output
14	OP OUT	O	
15,16	OP IN	I	OP amp input
17	CH3-OUT A	O	Feed motor drive output
18	CH3-OUT B		
21,22	Vcc	-	Power supply
23	BIAS IN	I	Input pin of Bias
26	CH4-OUT B	O	Tracking drive output
27	CH4-OUT A		

■ MN1281(P,Q) (IC971) : Reset IC

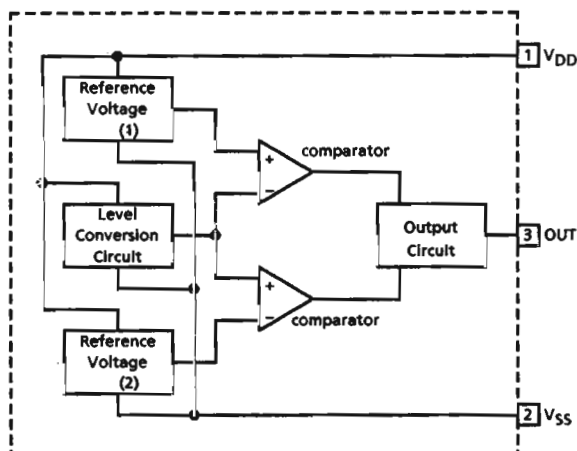

■ M5218AL (IC880/890)
XRA/BA15218 (IC940) : Dual OP Amp.

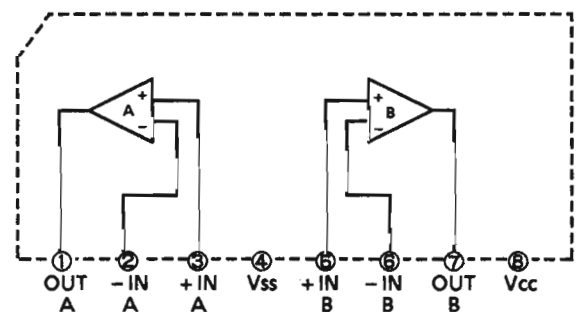

CD Section

	10G	9G	8G	7G	6G	5G	4G	3G	2G	1G
S1	(6)	DISC	CONTINUE	REPEAT		A.EDIT	A	1	2	3
S2	▷(6)	INTRO	PROGRAM	1		P.EDIT	B	6	7	4
S3	(5)	TRACK	RANDOM	STEP		EACH	REMAIN	11	12	5
S4	▷(5)	a	a	a	a	a	a	a	a	8
S5	(4)	b	b	b	b	b	b	b	b	9
S6	▷(4)	c	c	c	c	c	c	c	c	10
S7	(3)	d	d	d	d	d	d	d	d	13
S8	▷(3)	e	e	e	e	e	e	e	e	14
S9	(2)	f	f	f	f	f	f	f	f	15
S10	▷(2)	g	g	g	g	g	g	g	g	18
S11	(1)	(P)	▶	—		PITCH		16	17	19
S12	▷(1)	▷(P)	⏏			h		○ ○		20
S13	123456	P								

TUNER Section

	19G	18G	17G	16G	15G	14G	13G	12G	11G		19G	18G	17G	16G	15G	14G	13G	12G	11G	
S14	1	1	1	1	1	1	1	1	☺ DAILY	S32	19	19	19	19	19	19	19	19	19	S32
S15	2	2	2	2	2	2	2	2	ON TIME	S33	20	20	20	20	20	20	20	20	20	S33
S16	3	3	3	3	3	3	3	3	☹ REC	S34	21	21	21	21	21	21	21	21	21	S34
S17	4	4	4	4	4	4	4	4	CLOCK	S35	22	22	22	22	22	22	22	22	22	S35
S18	5	5	5	5	5	5	5	5	(SLEEP)	S36	23	23	23	23	23	23	23	23	23	S36
S19	6	6	6	6	6	6	6	6	MEMORY	S37	24	24	24	24	24	24	24	24	24	S37
S20	7	7	7	7	7	7	7	7	(CD)	S38	25	25	25	25	25	25	25	25	25	S38
S21	8	8	8	8	8	8	8	8	(FM)	S39	26	26	26	26	26	26	26	26	26	S39
S22	9	9	9	9	9	9	9	9	(TAPE)	S40	27	27	27	27	27	27	27	27	27	S40
S23	10	10	10	10	10	10	10	10	(AM)	S41	28	28	28	28	28	28	28	28	28	S41
S24	11	11	11	11	11	11	11	11	AUTO	S42	29	29	29	29	29	29	29	29	29	S42
S25	12	12	12	12	12	12	12	12	TUNED	S43	30	30	30	30	30	30	30	30	30	S43
S26	13	13	13	13	13	13	13	13	STEREO	S44	31	31	31	31	31	31	31	31	31	S44
S27	14	14	14	14	14	14	14	14	MONO	S45	32	32	32	32	32	32	32	32	32	S45
S28	15	15	15	15	15	15	15	15	REC TIME	S46	33	33	33	33	33	33	33	33	33	
S29	16	16	16	16	16	16	16	16	VOLUME	S47	34	34	34	34	34	34	34	34	34	kHz
S30	17	17	17	17	17	17	17	17	CH	S48	35	35	35	35	35	35	35	35	35	MHz
S31	18	18	18	18	18	18	18	18	S31											

Disassembly Procedures

(1) Removing the Top cover

1. Remove the 2 screws fixing both sides of the Top Cover, and the 4 screws fixing the rear sides.
2. Remove the Top Cover.

(2) Removing the CD-Tuner PCB (ENA-150)

1. Remove the Top Cover.
2. Remove the 4 screws ㉔.
3. Remove the 2 screws fixing the CD-Tuner PCB.
4. Disconnect the connectors.
(P201,P903,P904,J711,J721,J901,FW801,FW803,FW831,JB201,JB202)
5. Remove the CD-Tuner PCB.

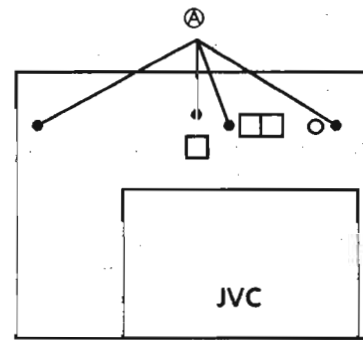

Fig.1

(3) Removing the Front door open/close mecha ass'y

1. Remove the CD-Tuner PCB.
2. Rotate the cam gear ㉓ backward to open the Front door for 45°.
3. Remove the 2 screws ㉕ fixing the Front door open/close mecha ass'y.
4. Remove the Front door open/close mecha ass'y.

(4) Removing the Front panel ass'y

1. Remove the Front door open/close mecha ass'y.
2. By inserting a thin driver from upside of the mecha ㉗, rotate the gear ㉚ (see fig.-11) counterclockwise to eject the tray. And, shift the tray to remove the fitting after unlocking the bottom of the rail base ass'y.
3. Remove the 3 screws ㉖ fixing bottom of the Front panel ass'y.
4. Remove the Front panel ass'y.

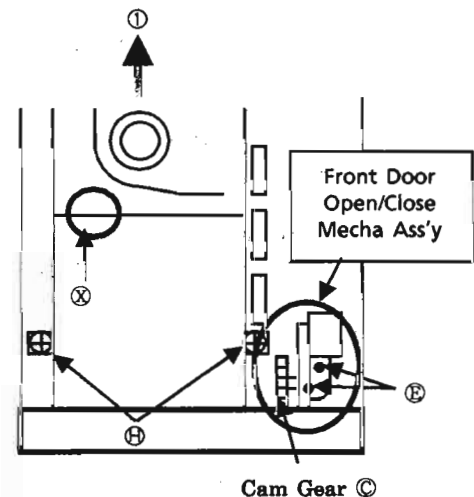

Fig.2

(5) Removing the Front door indicator PCB (ENB-181-2)

1. Remove the 2 screws ㉕.
2. Rotate the cam gear ㉓ backward to open the Front door.
3. Remove the hook by inserting a thin driver from ㉗ hole to remove the Front door indicator ass'y.
4. Remove the 3 screws fixing the Front door indicator PCB.
5. Remove the Front door indicator PCB.

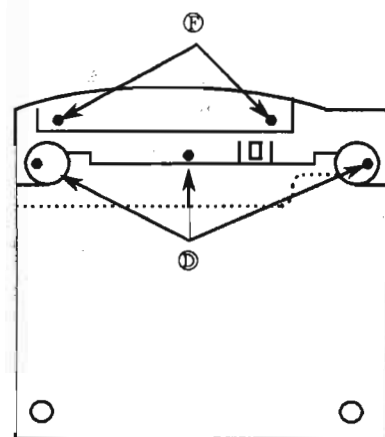

Fig.3

(6) Removing the Changer mecha ass'y

1. Remove the CD-Tuner PCB.
2. Rotate the cam gear ㉓ backward to open the Front door.
3. By inserting a thin driver from upside of the mecha ㉗, rotate the gear ㉚ (see fig.-11) counterclockwise to eject the tray. And, shift the tray to remove the fitting after unlocking the bottom of the rail base ass'y.
4. Remove the 2 screws ㉖ fixing the Changer mecha ass'y.
5. Slide the Changer mecha ass'y to arrow direction ㉑.
6. Remove the Changer mecha ass'y.

* NOTICE (for reinstalling)

Wire ㉑ should be set as Fig.6.

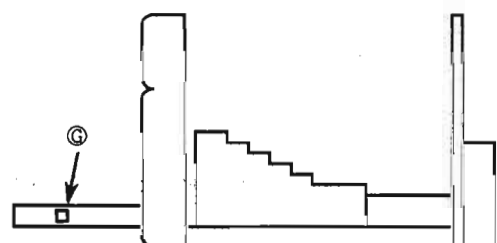

Fig.4

(7) Removing the magazine

1. Rotate the lock-lever to arrow direction ②.
2. Pull the magazine.

(8) Removing the turntable base

1. Remove the changer mecha ass'y.
2. Turn over the changer mecha ass'y.
3. Remove the 3 screws ①.

* NOTICE : The left side spring differs from the right side ones.

4. Take out the turntable base.

(9) Exchanging the pickup

1. Take out the turntable base.
2. Cut the tie-band
3. Remove the screw ④, and remove the feed nut support.
4. Remove the feed screw ass'y.
5. Remove the Screw ①, and remove the Pickup with the pickup shaft.
6. Exchange the pickup.

(10) Removing the magazine holder

1. Remove the 2 screws fixing the magazine holder.
2. Slide the lift cam backward.
3. Slide the magazine holder backward, and remove the magazine holder to upside.

(11) Removing the LIFTER UNIT Ass'y

1. Remove the magazine holder.
2. Lift the LIFTER UNIT Ass'y to the top position.
3. Remove the ELEVATOR ARMS from the CHASSIS BASE and the LIFTER UNIT Ass'y.
4. Remove the LIFTER UNIT Ass'y.

※ **The LIFT CAM can be released, After removing the LIFTER UNIT Ass'y**

1. When installing the lift cam, Put the cam slider to the position shown in fig 5.
 2. Install the changer assembly.
 3. Set the power ON to operate the mechanism.
 4. Set the power OFF while the disc is playing.
 5. Set the power ON again.
- In this case the unit will be reseted.

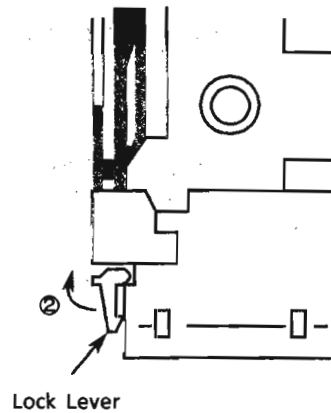

Fig..5

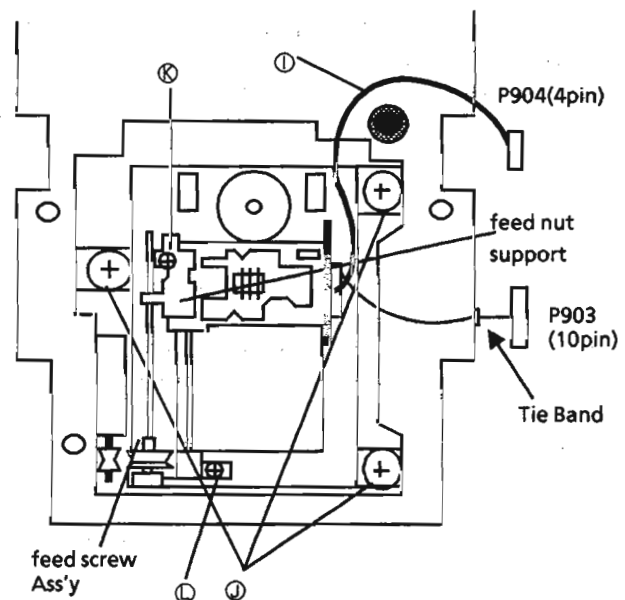

Fig.6

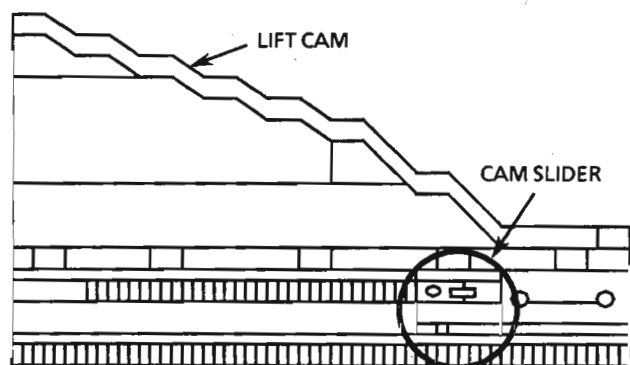

Fig.7

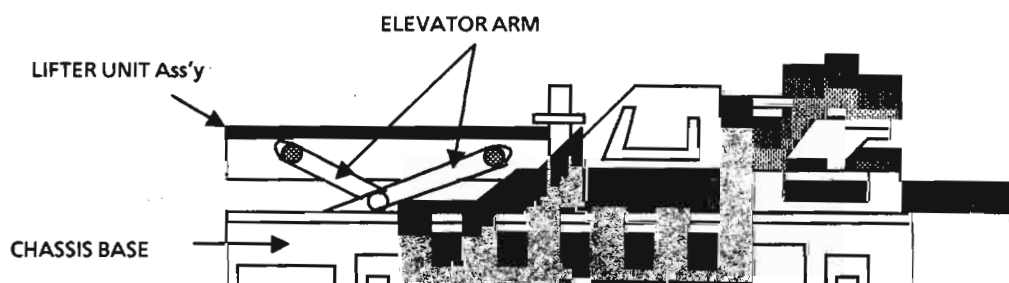

Fig.8

(12) Removing the P1 RAIL BASE

1. Remove the magazine holder.
 2. Rotate the gear ㉞ clockwise a little.
 3. Pull out the P1 RAIL BASE.
 4. Pull the P1 TRAY backward.
 5. Remove the screw fixing the open/close sw by inserting a thin driver from ㉟ hole to remove the Front door indicator ass'y.
 6. Pull the P1 RAIL BASE by pulling up the hook ㉟ slightly.
 7. Remove the P1 RAIL BASE.
- ※ Install gear ㉟ so that part ㉟ shown in fig.10 is perpendicular to the P1 rail base.

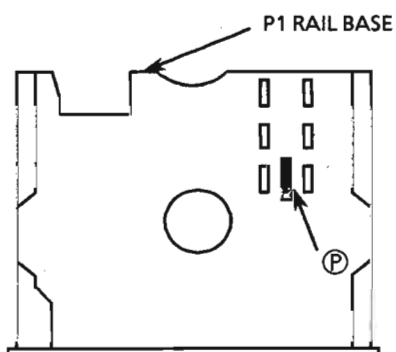

Fig.9

The Gear Position when the P1 Rail Base is pulled out forward.

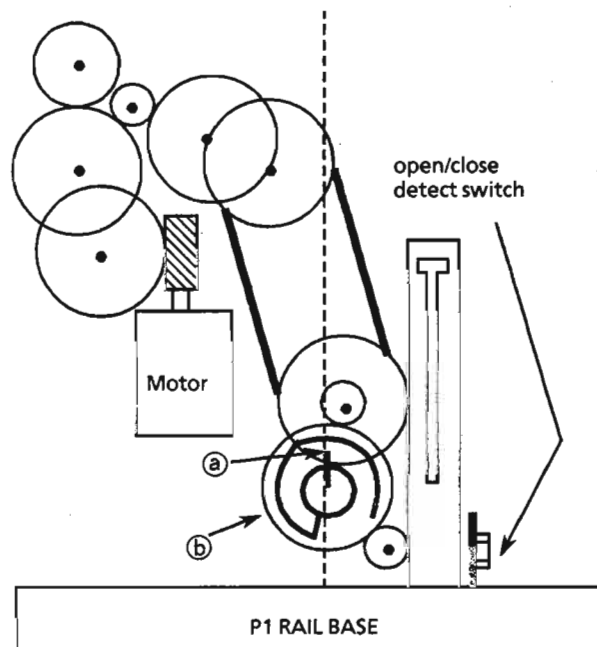

Fig.10

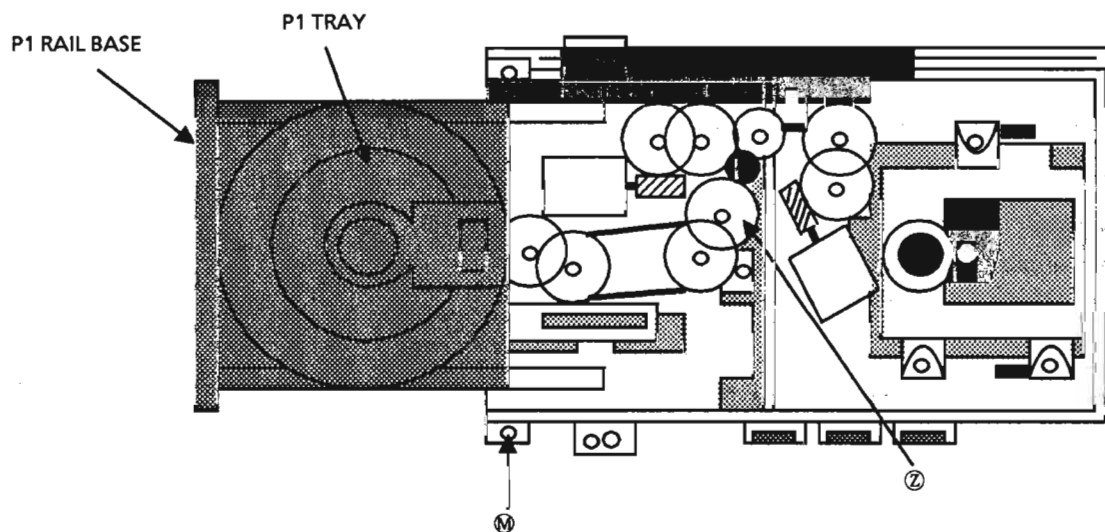

Fig.11

(13) Removing the spindle motor

1. Remove the TURN TABLE BASE.
2. Turn over TURN TABLE BASE.
3. Remove the pressed-in turntable.
4. Remove the 2 screws fixing the motor.
5. Remove the spindle motor.

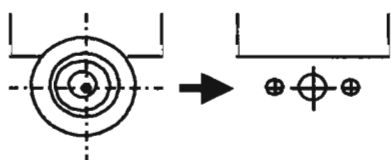

Fig.12

(14) Mounting the spindle motor

1. Alternately tighten the 2 screws.
2. Fit the turntable by pressing gently at the centre to obtain a distance of 10.3mm ± 0.1mm from the mechanism base to the top of the turntable.

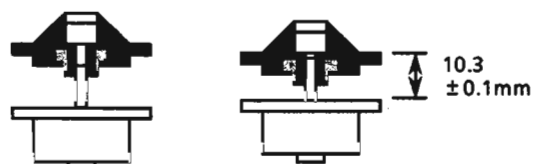
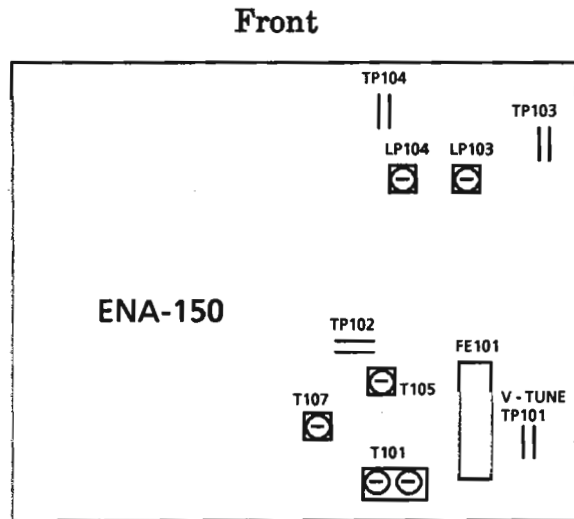
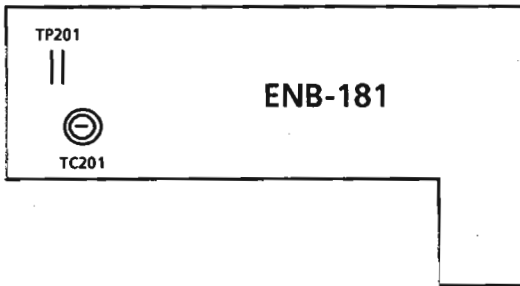

Fig.13

Adjustment Procedures

■ Tuner section



Rear

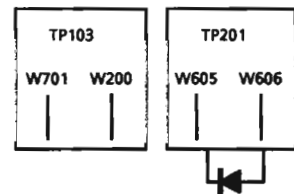

例 1S5133 1S2076
1S5119 1S2473

(1) Clock Adjustment

1. After connecting W605 and W606 with some wire, connect ac power cord into ac outlet.
2. Confirm that the display is off and remove the wire.
3. Connect a frequency counter to TP103 (W701).
4. Adjust TC201 so that the frequency becomes $50000 \pm 0.29\text{Hz}$.

(2) Tuning voltage

Confirm the voltages in the table below at TP101. If the voltages are not satisfied, replace T101 for AM or FE101 for FM.

FM Tuning voltage (Unit : V)

Frequency	FM		AM	
	76MHz	108MHz	522kHz	1629KHz
Tuning voltage	> 1.0	< 10.0	> 0.5	< 8.5

(3) FM center meter

Receive a broadcast by using the function of 'AUTO STOP'.
Adjust T105 (detector coil) so that the voltage at TP102 becomes $0 \pm 1.5\text{mV}$.

(NOTE) Adjustment is not necessary for CD section.

Maintenance of Laser Pickup

(1) Life of the laser diode

When the life of the laser diode has expired, the following symptoms will appear.

1. The level of RF output (EFM output: amplitude of eye pattern) will be low.
2. The drive current required by the laser diode will be increased. In such a case, check the life of the laser diode following the flowchart below.

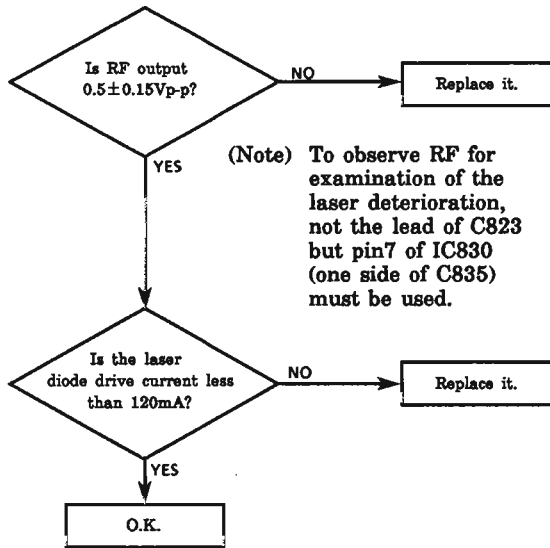

(2) Measurement of laser diode drive current

Replace the jump wire (W212) shown below with the resistor (1Ω). Disconnect right lead of R830 and R843 to connect W212, R830 and R843 as followings.

Measure the voltage across the resistor (1Ω) with a milli-voltmeter. When the voltage is more than 120mV, it shows that the life of the laser diode has expired.

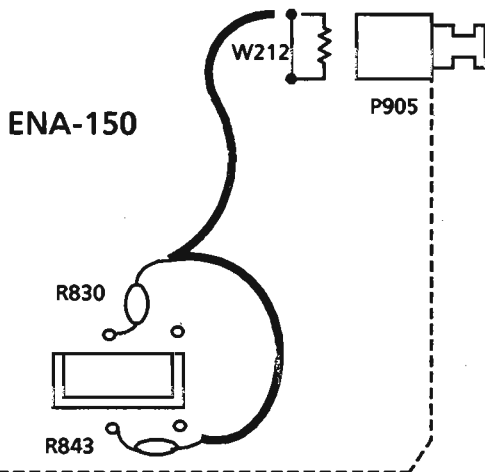

(3) Semi-fixed resistor on the APC PC board

The semi-fixed resistor on the APC printed circuit board which is attached to the pickup is used to adjust the laser power. Since this adjustment should be performed to match the characteristics of the whole optical block, do not touch the semi-fixed resistor.

If the laser power is lower than the specified value, the laser diode is almost worn out, and the laser pickup should be replaced.

If the semi-fixed resistor is adjusted while the pickup is functioning normally, the laser pickup may be damaged due to excessive current.

Replacement of Laser Pickup

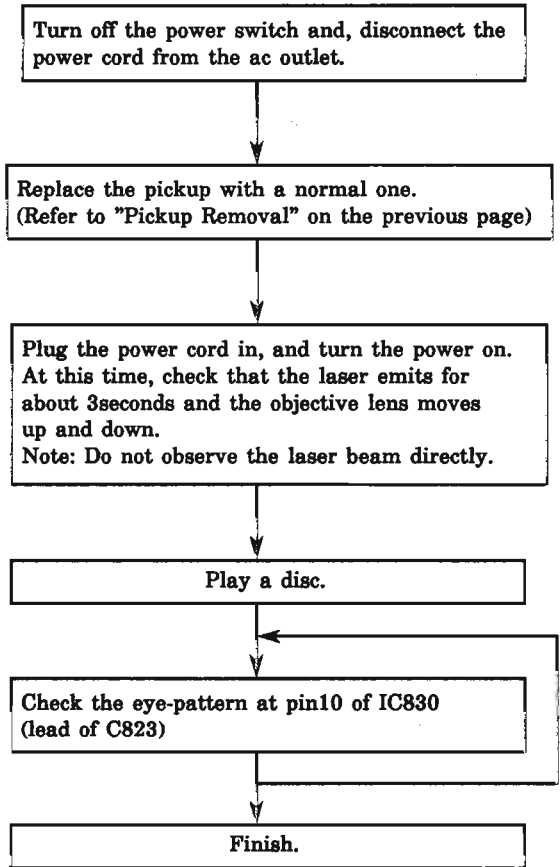

Flow of Functional Operation Until TOC is Read

Check Points

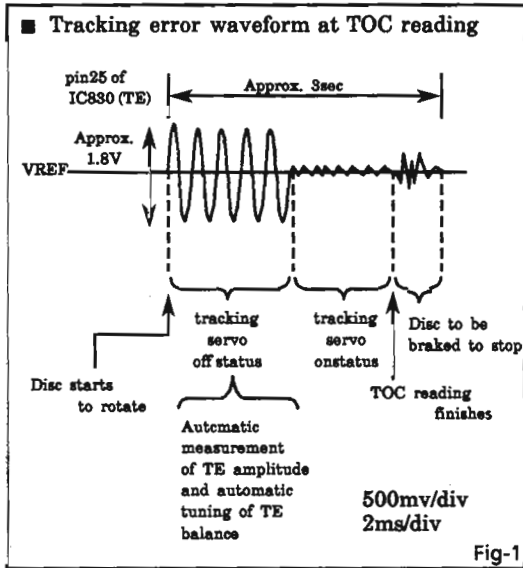
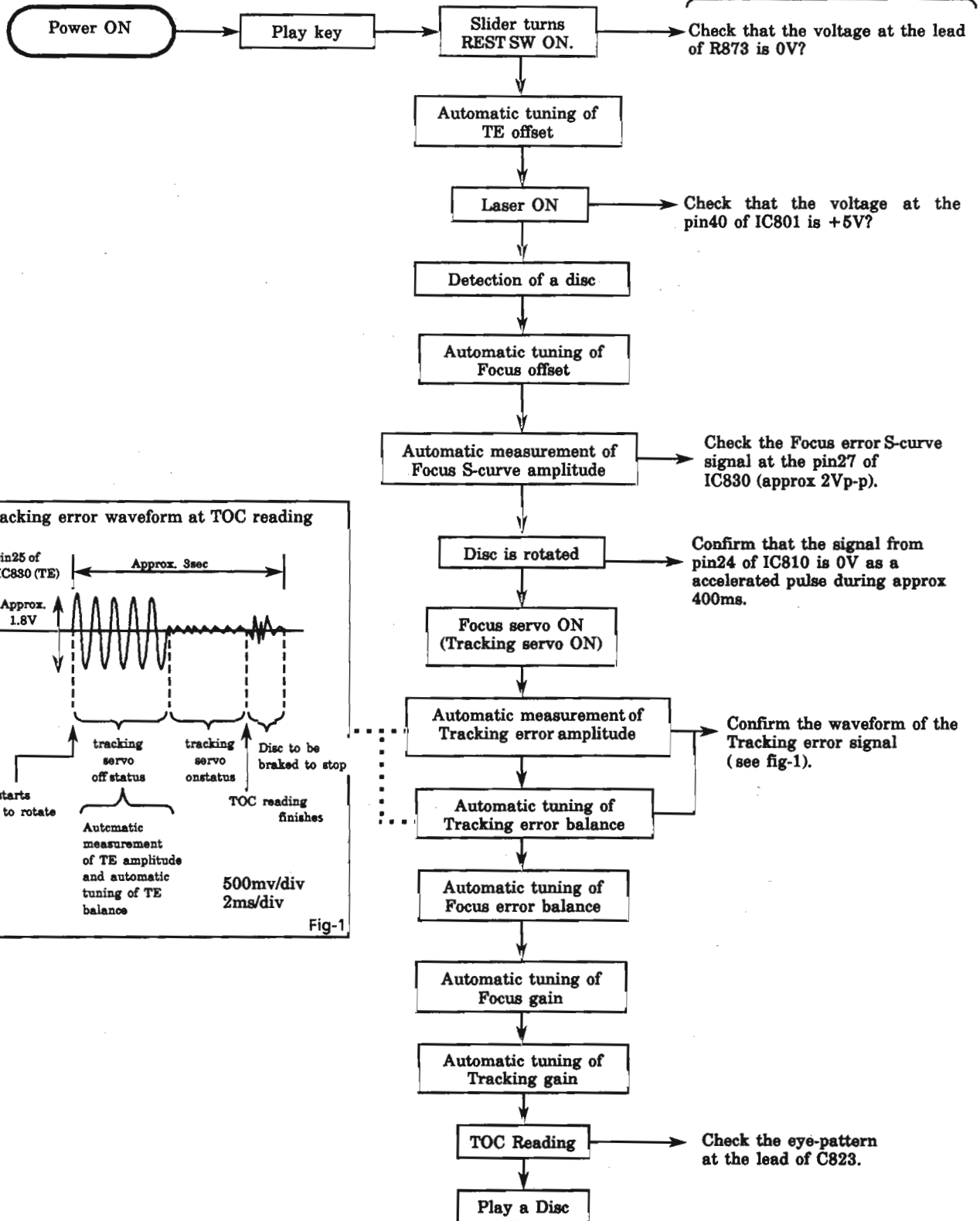

Operation check by each switch.

- SW801 : Single tray open / close detect switch.
When a single tray is ejected, the open signal is "L" and when it is closed, the close signal is "L".
- SW802 : Magazine in switch.
When a magazine is inserted, the switch is turned on.
- SW803 : JAB switch.
When drive plate comes toward, the switch is turned on. (The switch is turned on momentarily.)
- SW803 : Tray load switch.
When the tray of a disc is loaded, the switch is turned on.
- SW804 : UP/DOWN switch.
When the mechanism goes up or down, this sw turns on and off alternately.
- SW805 : Reset switch.
When the mechanism comes to the point under the initial position, the switch is turned on.
- SW805 : Memory switch.
When the power is off in playing a disc, and on again, the switch detect which height the tray should be returned.
- SW807 : Pickup rest switch.
When pickup comes to the initial position, the switch is turned on.
- SW251 : FD Close switch.
This switch turns on when the front door is closed.
- SW252 : FD Open switch.
This switch turns on when the front door is opened.

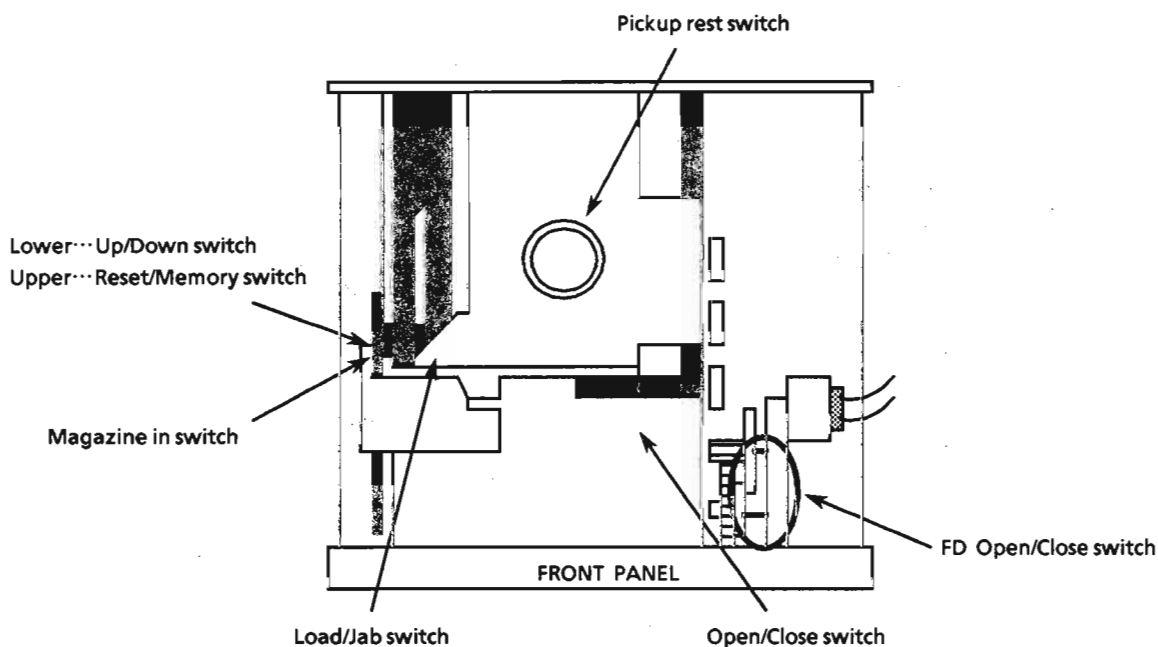

Initial Operation of Mechanism

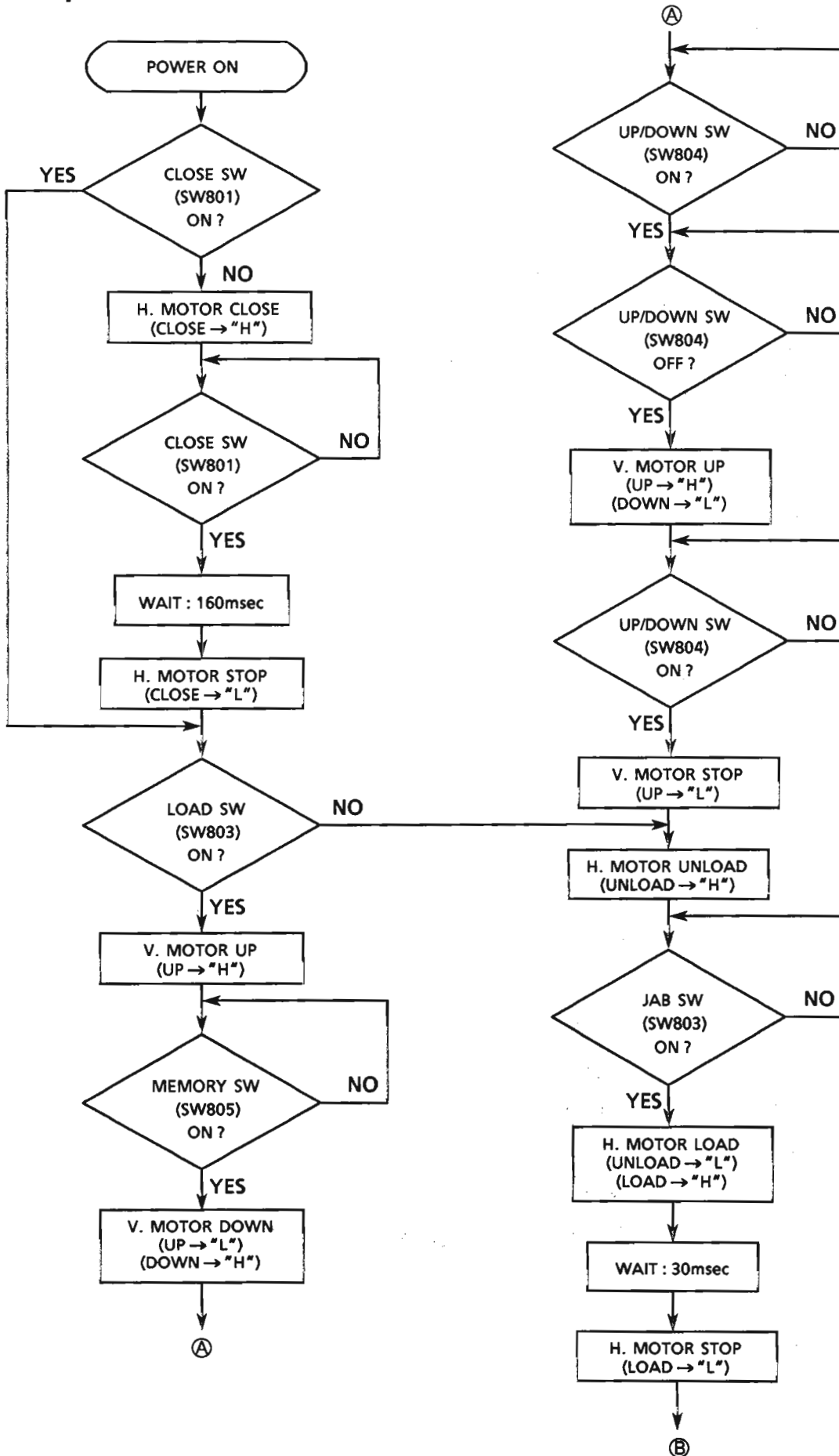

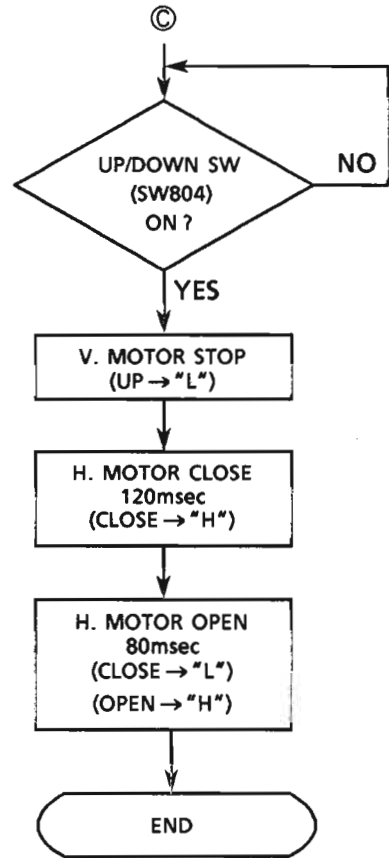
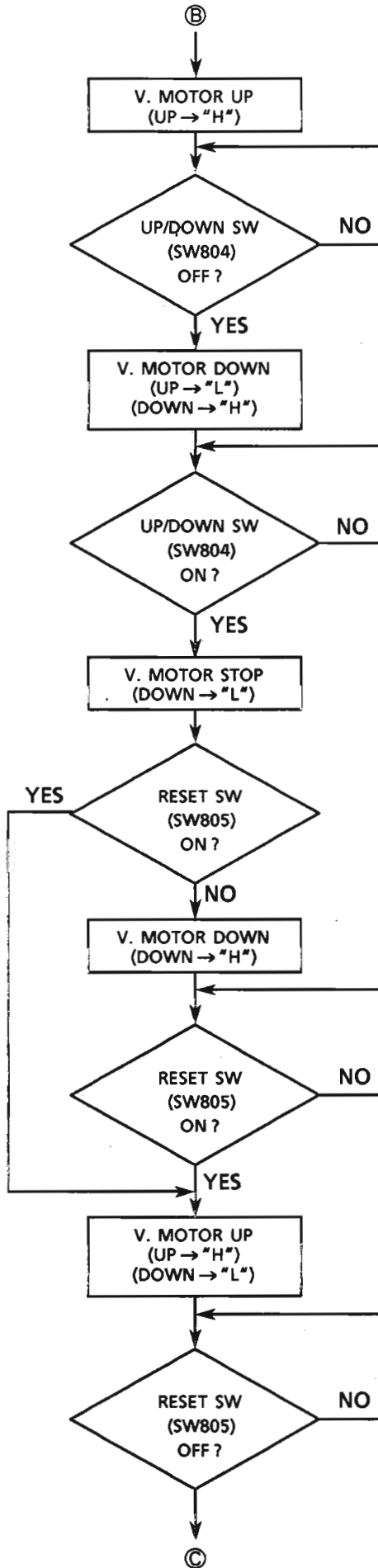

Troubleshooting

The following shows the status of the various circuits from turning on the power to the start of disc play.

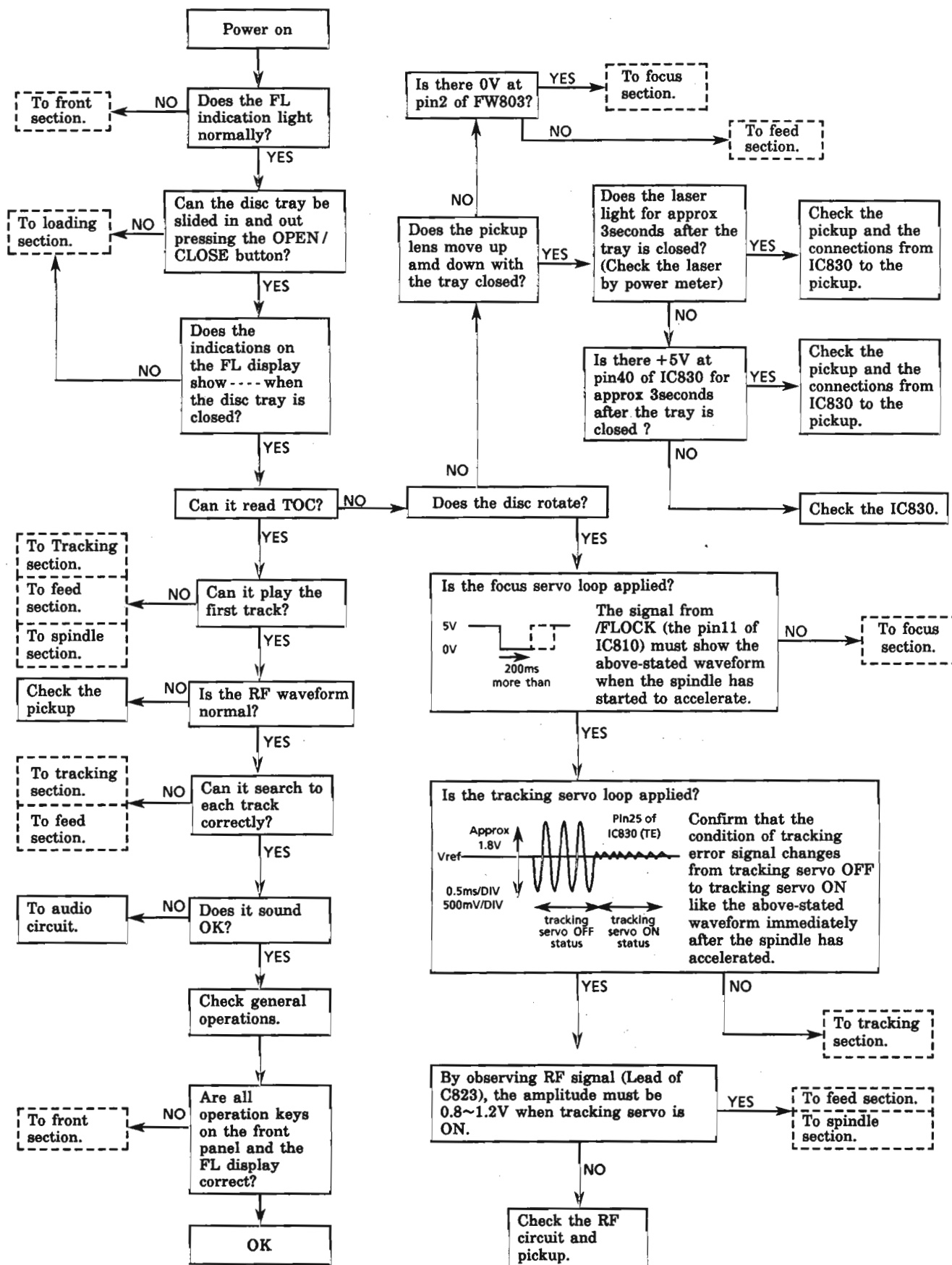

Front Section

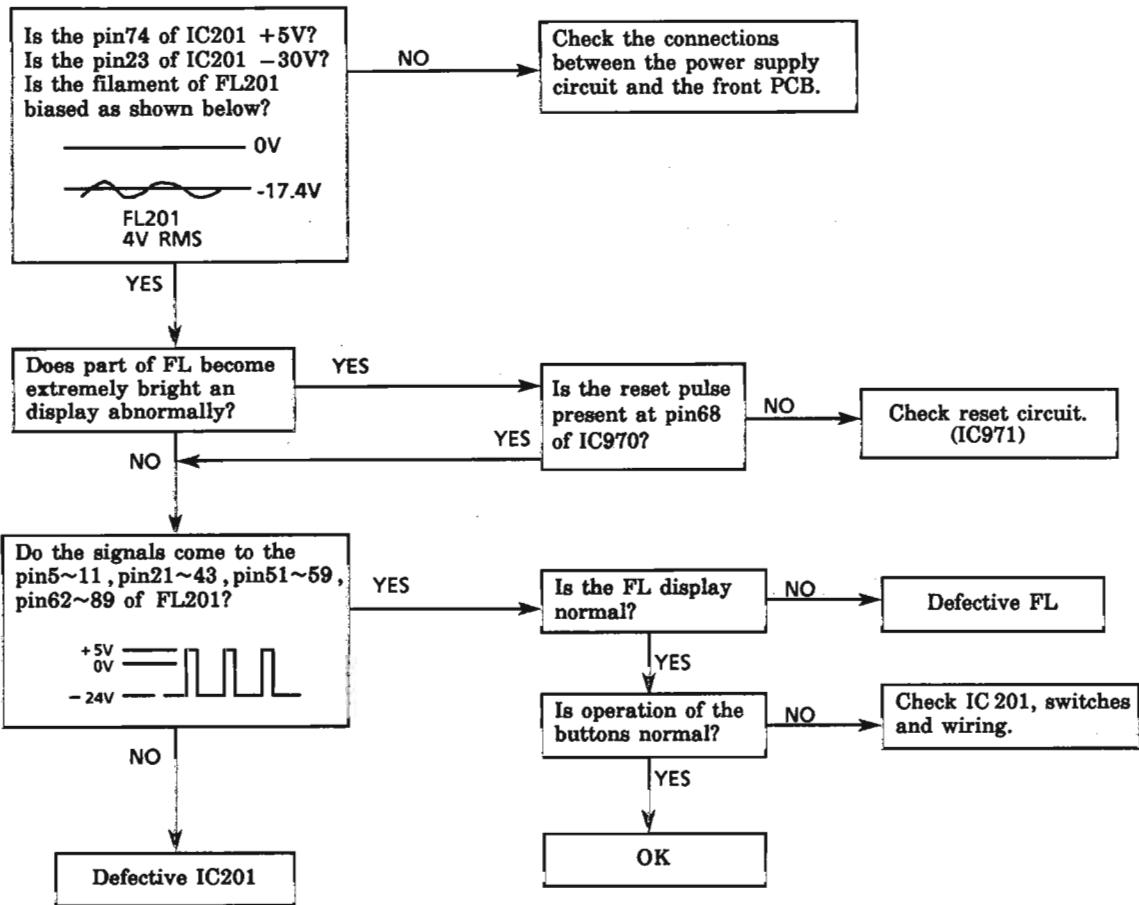

Focus section

Note) When checking the voltages between pin1 and pin2 of IC860 with an oscilloscope, do not connect the other probes.

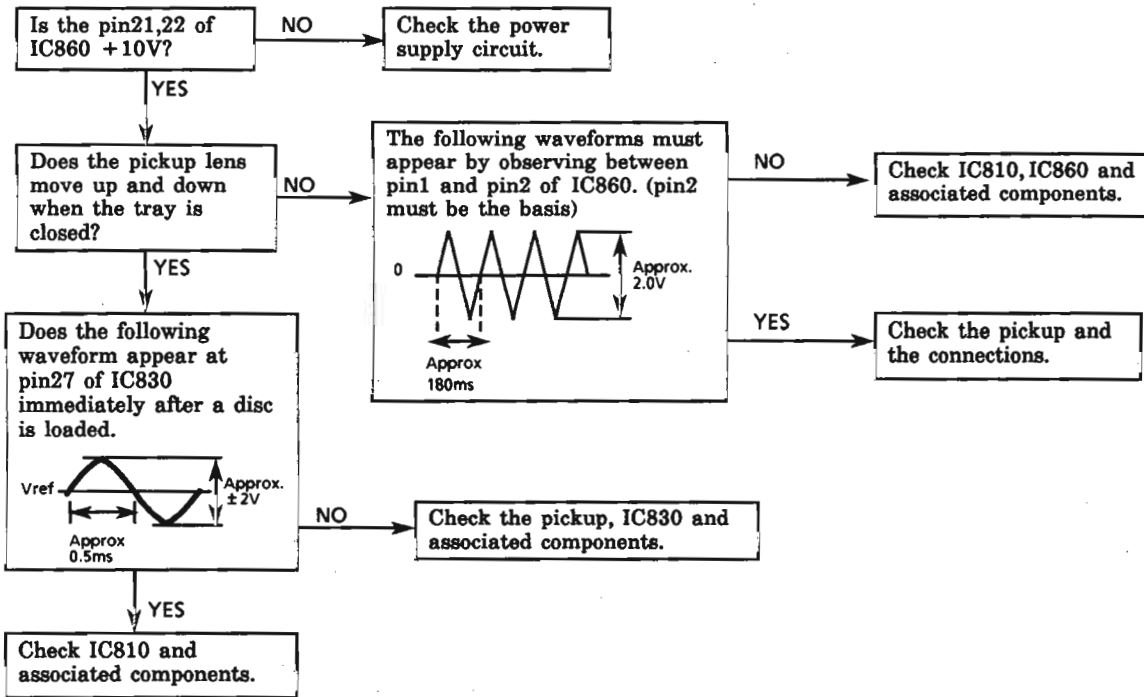

Tracking section

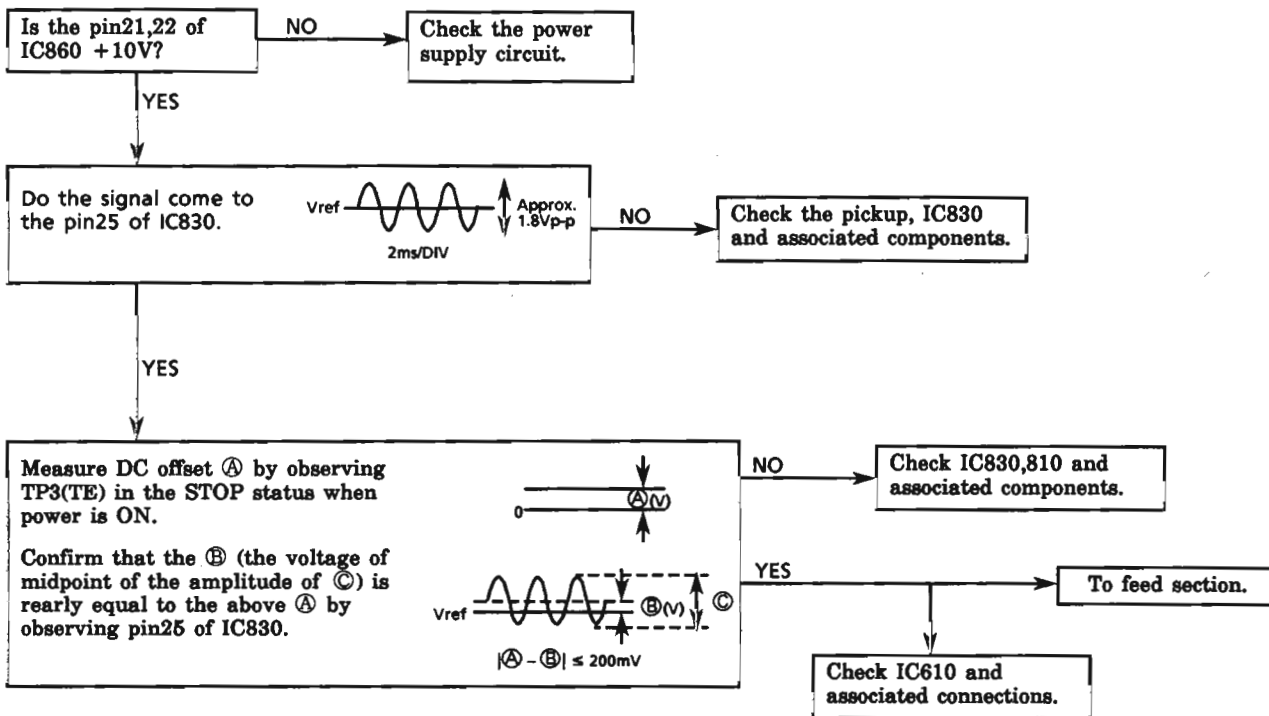

Feed section

Note) When checking the voltages between pin18 and pin17 of IC860 with an oscilloscope, do not connect the other probes.

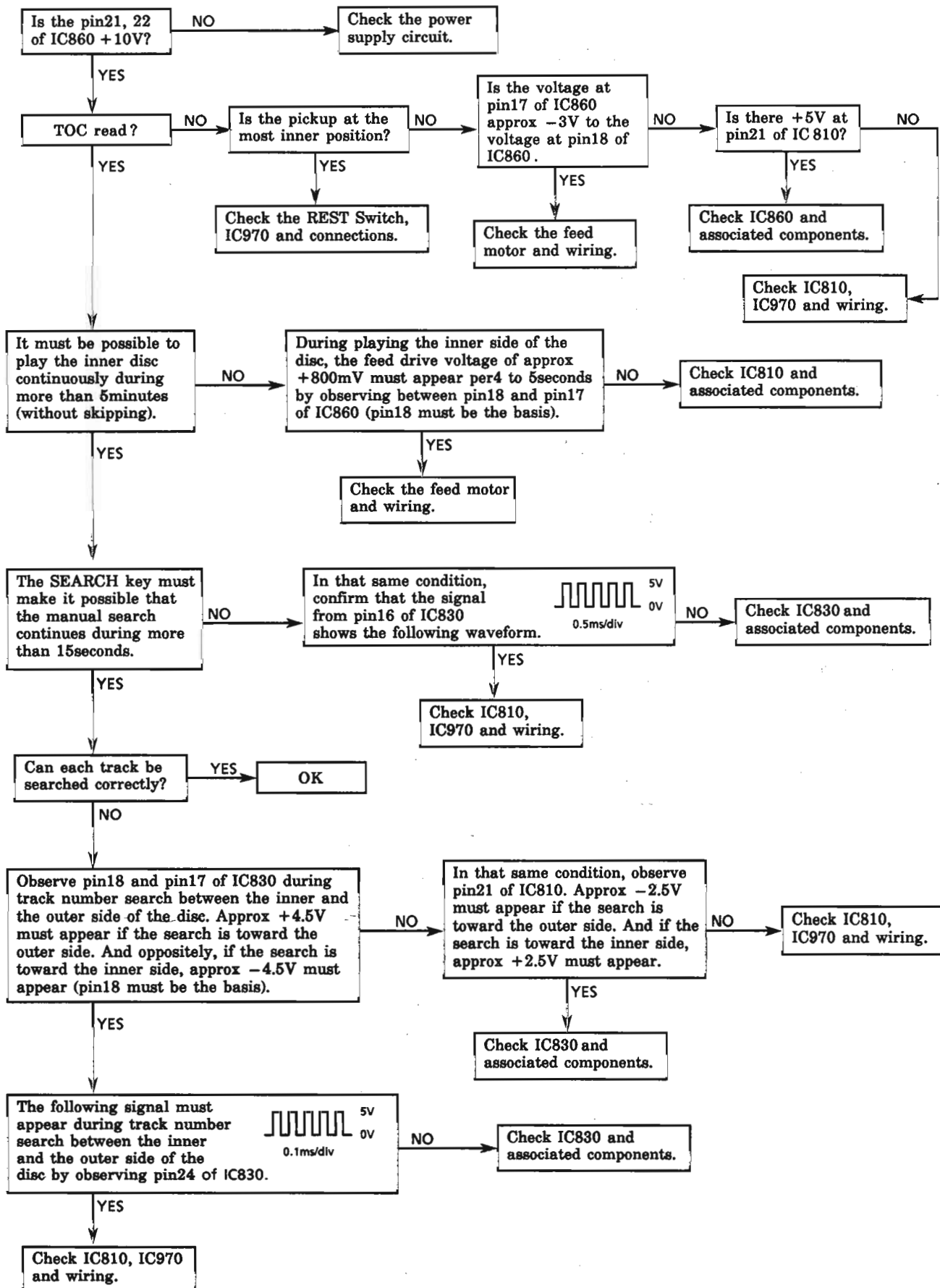

Spindle section

Note) When checking the voltages between pin11 and pin12 of IC860 with an oscilloscope, do not connect the other probes.

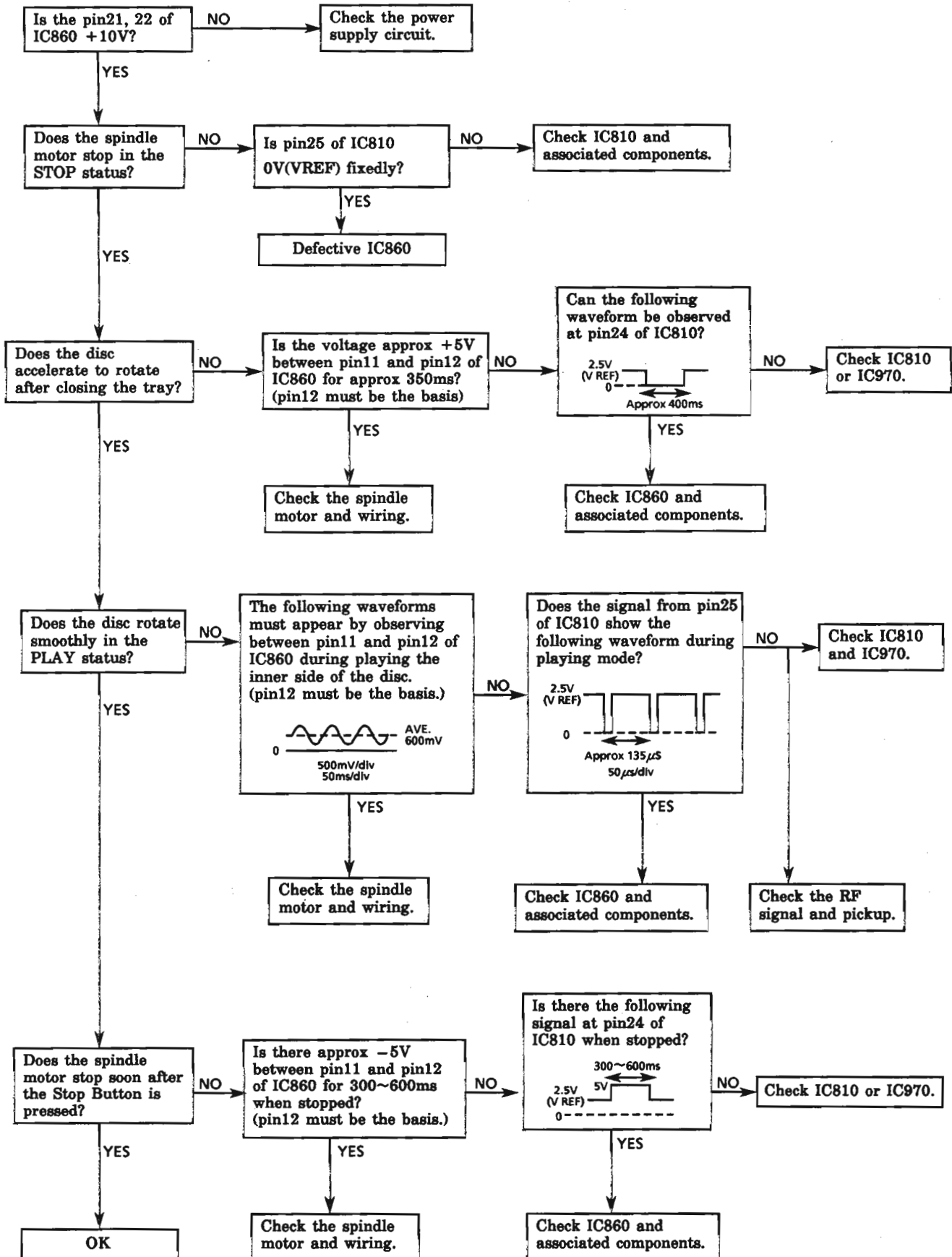

Block Diagram

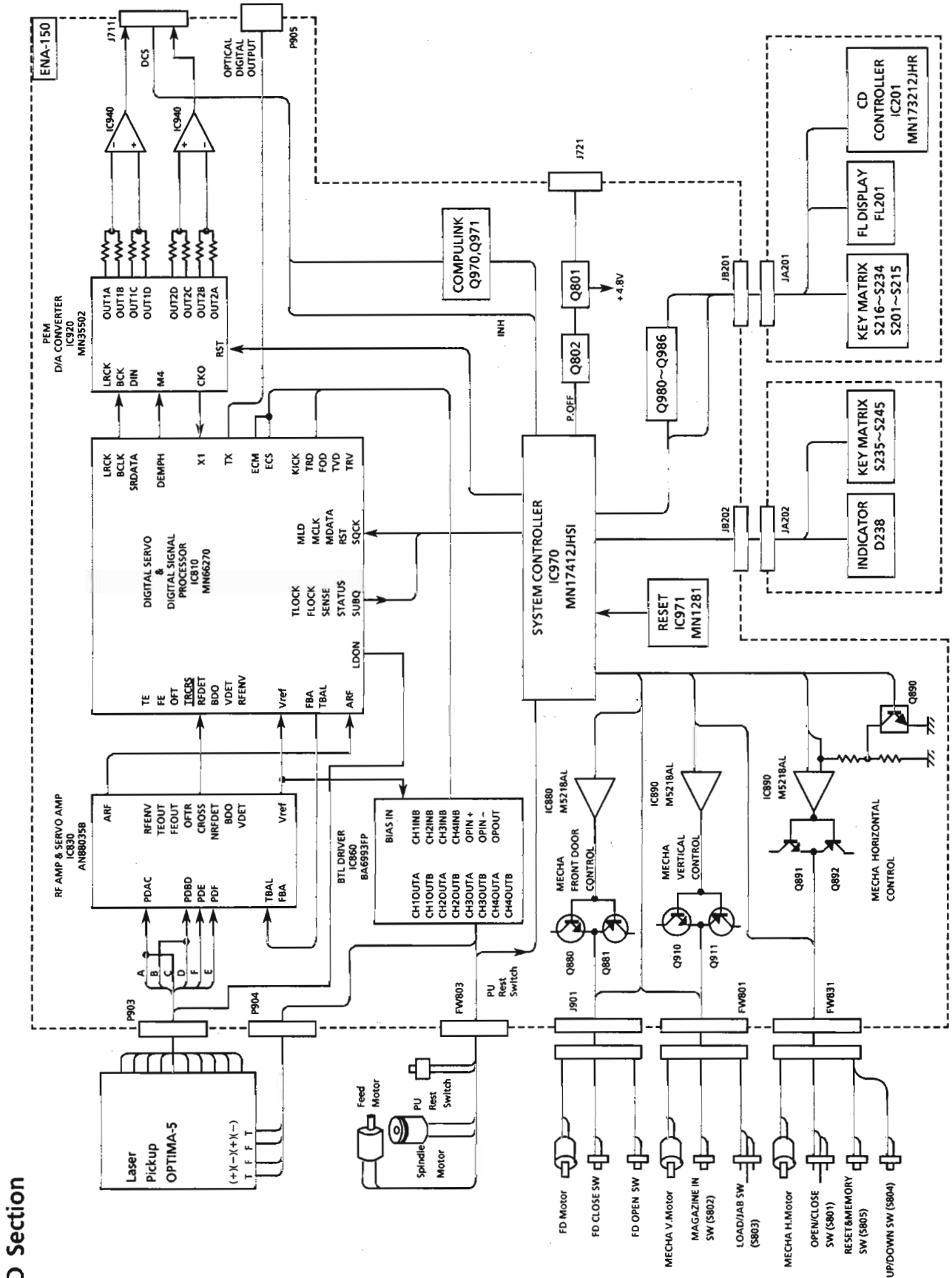

CD Section

■ Tuner Section

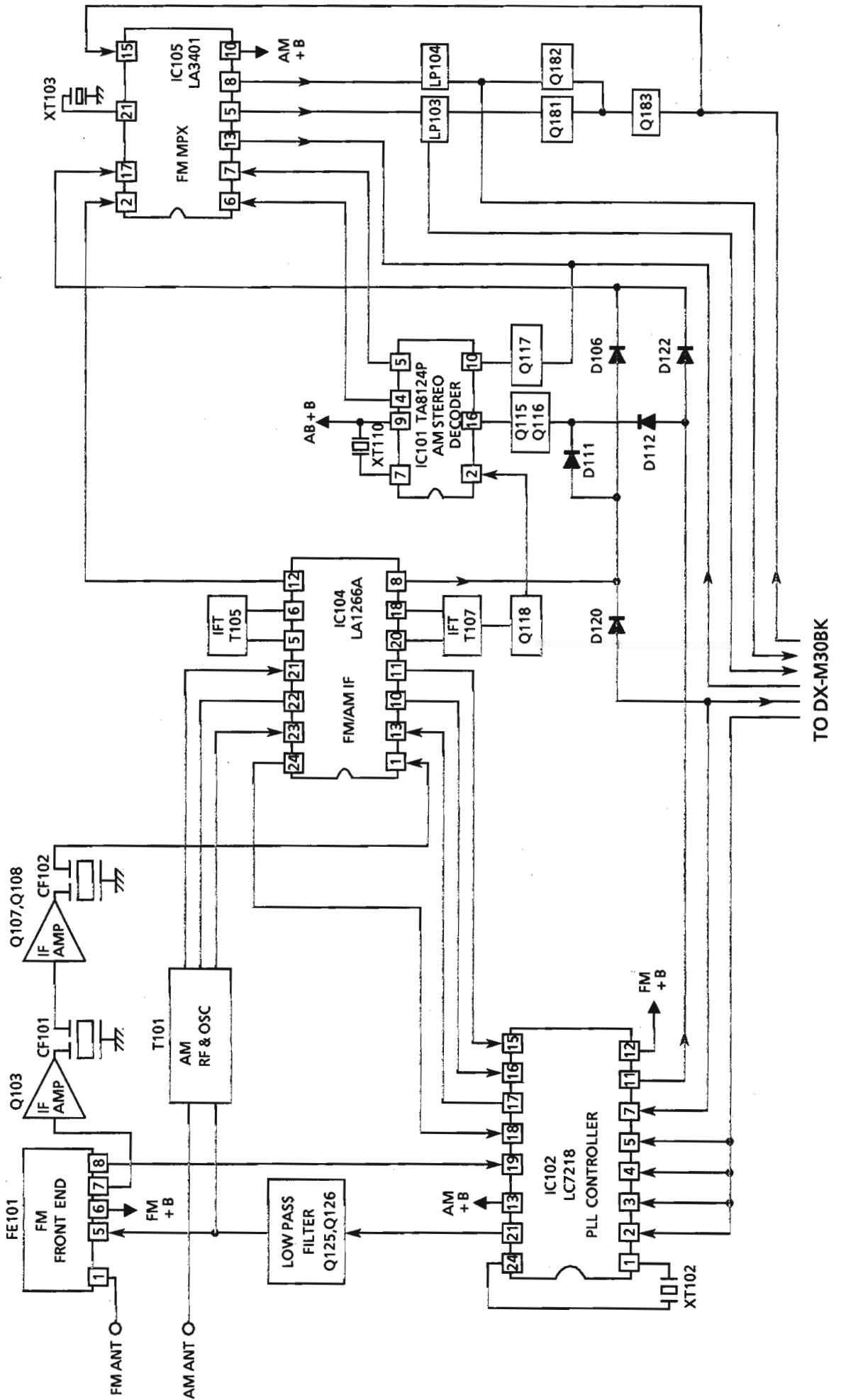

P73-a

P73-b

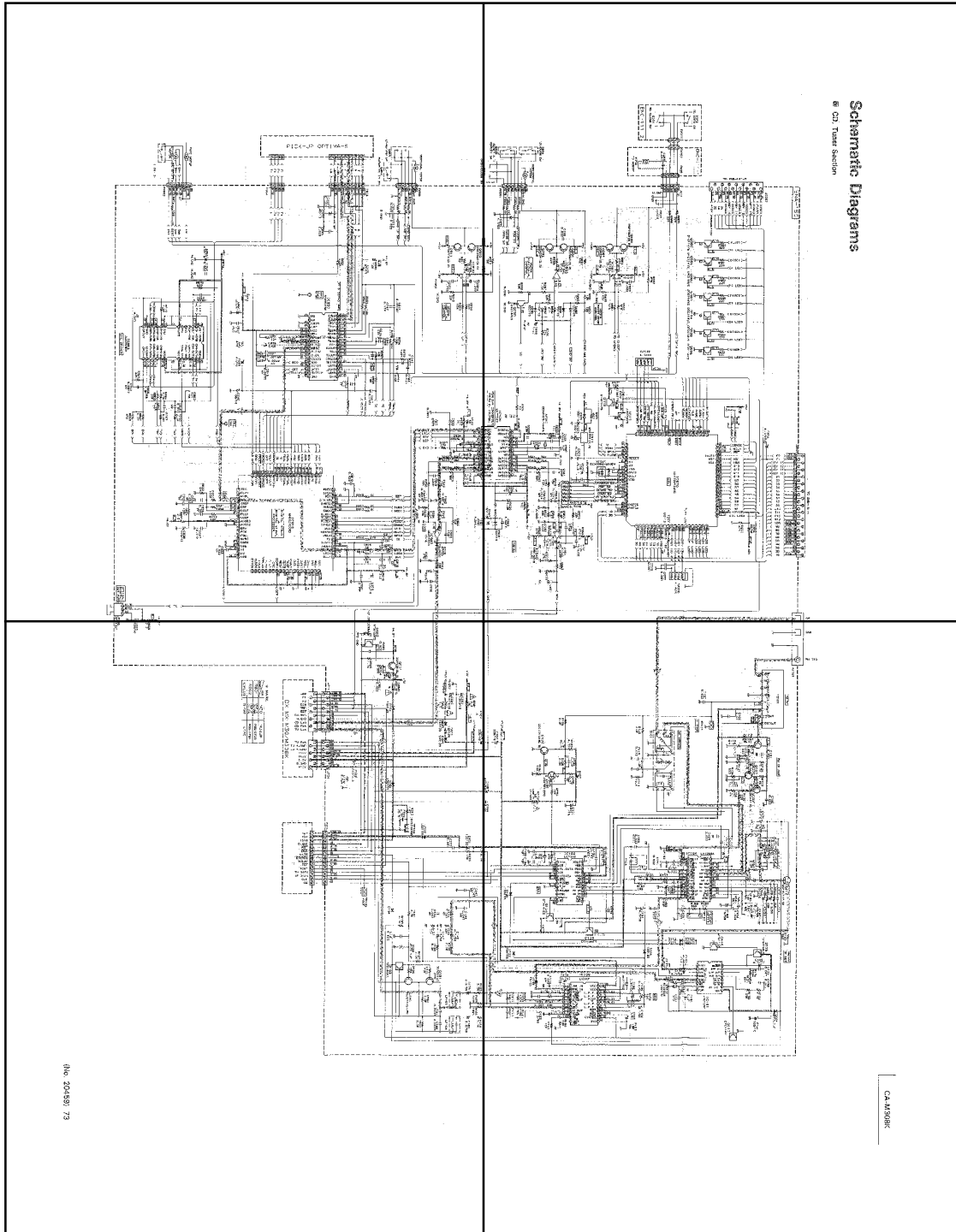

P73-c

P73-d

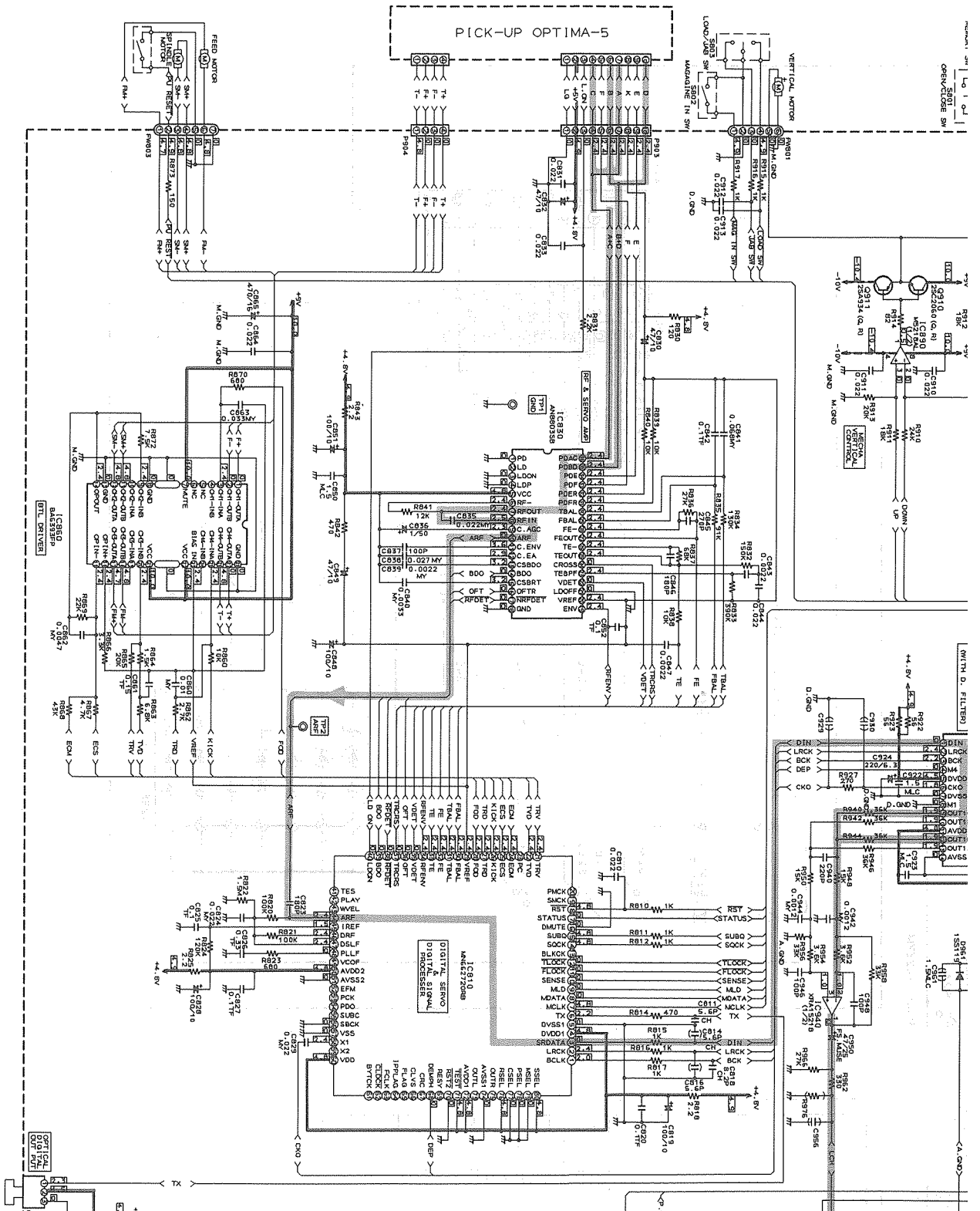

Schematic Diagrams

■ CD, Tuner Section

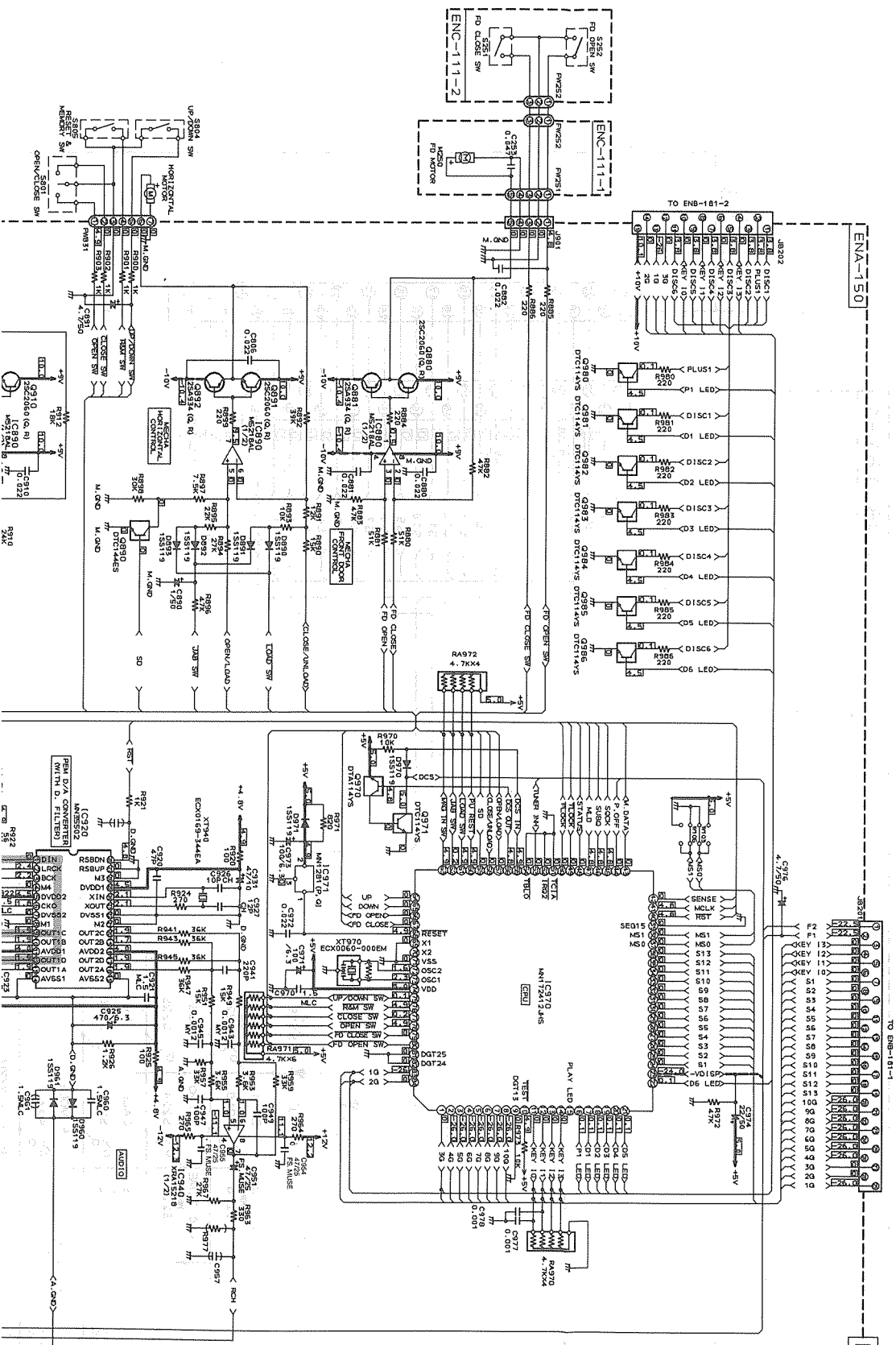

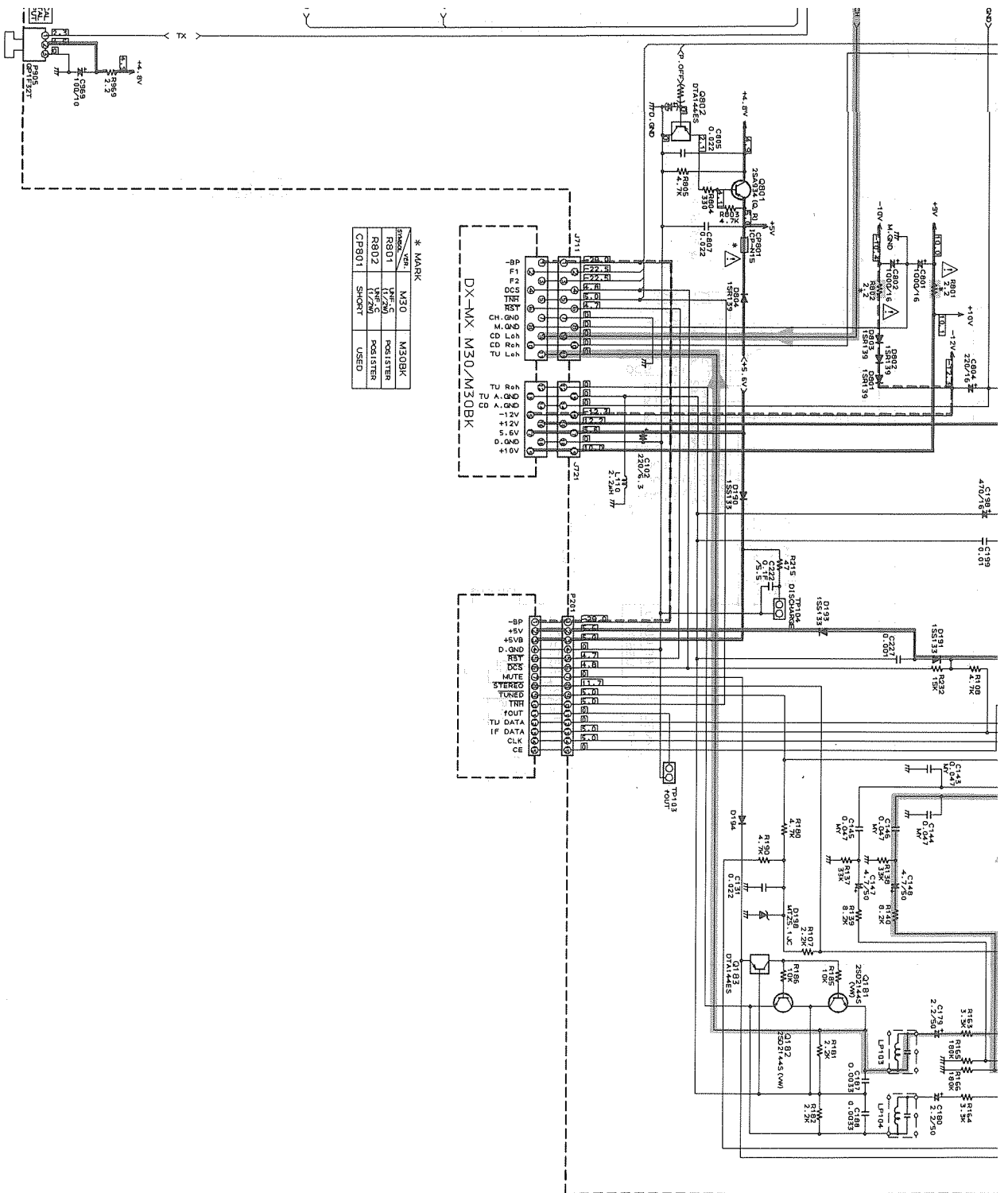

* MARK

6X4	M30	M30BK
6AR5	TV750	POSTER
R801	TV750	POSTER
R802	TV750	POSTER
CP801	SHORT	USED

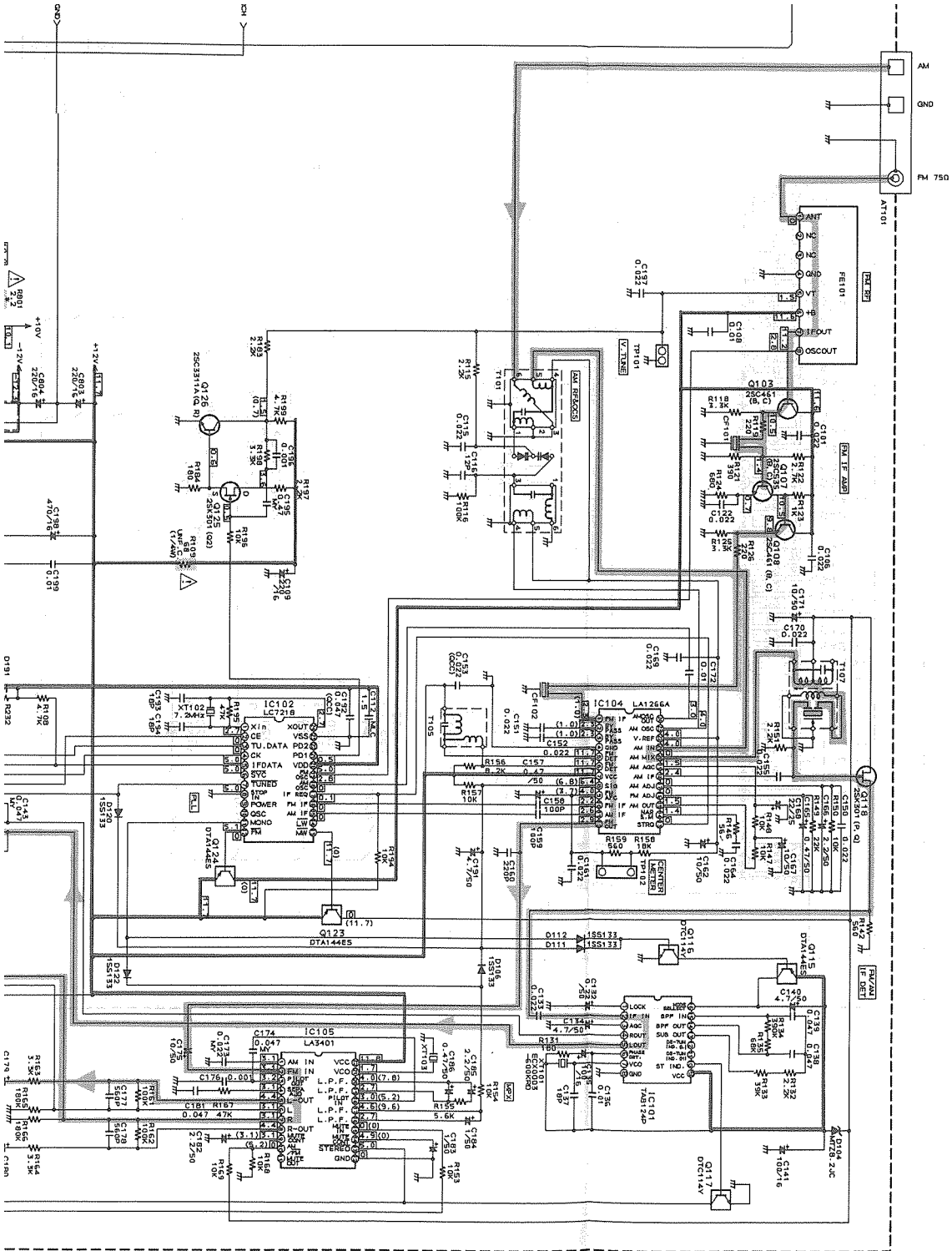

CA-M30BK

P74-a

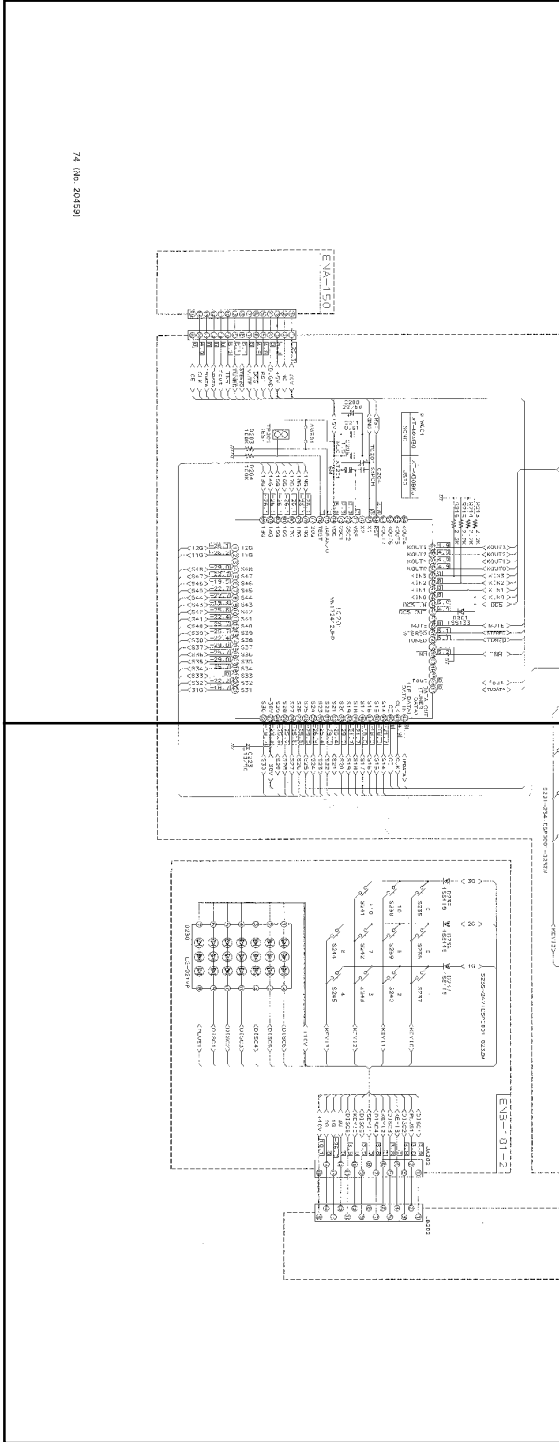

P74-c

P74-b

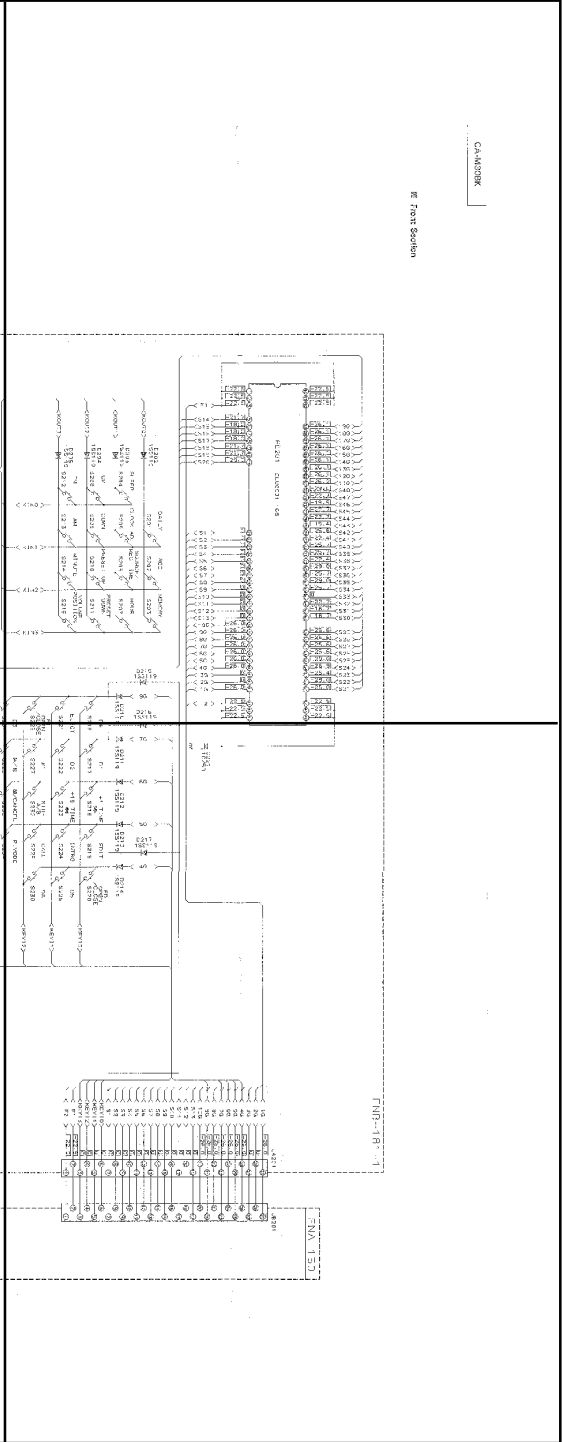

P74-d

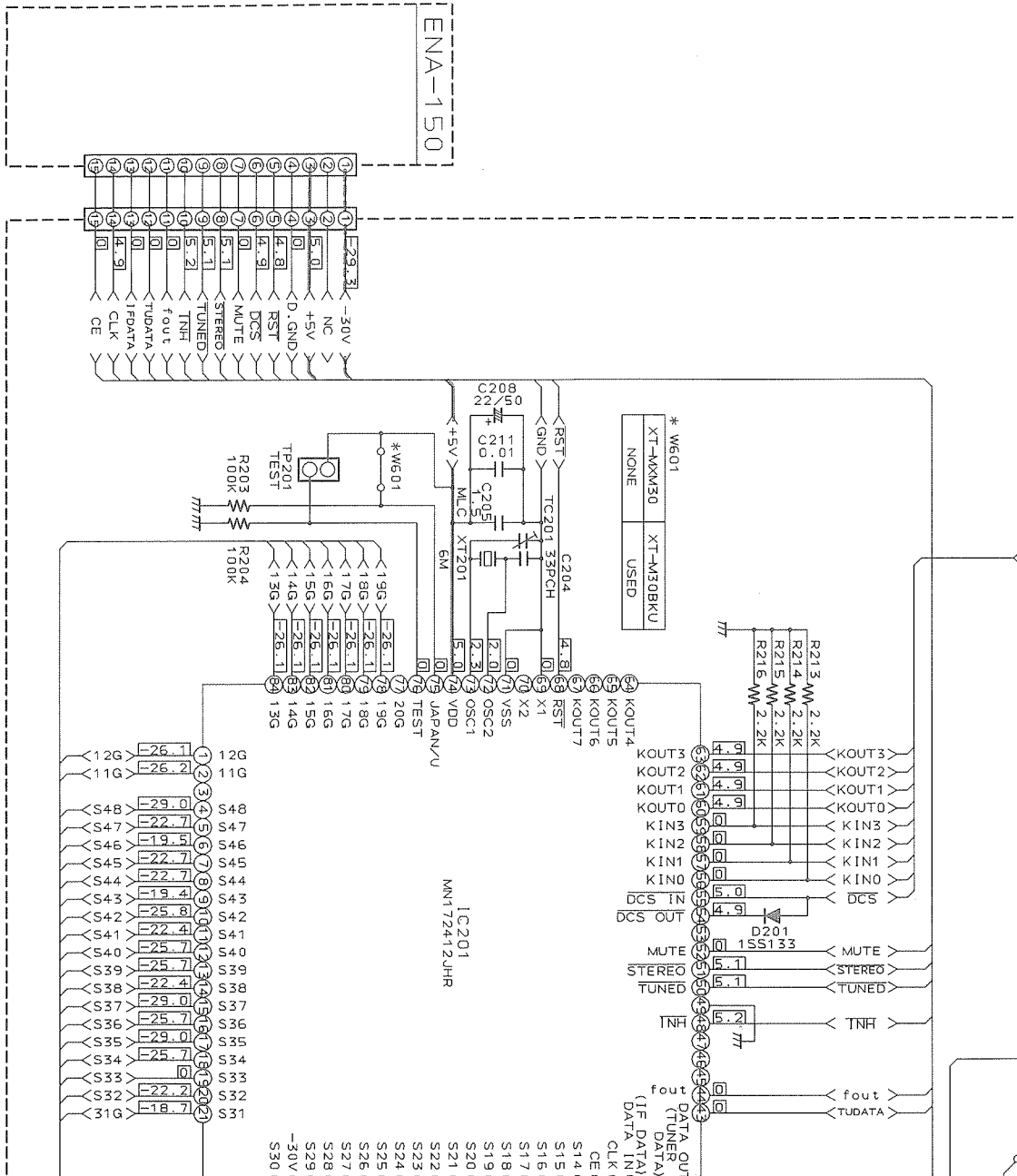

Front Section

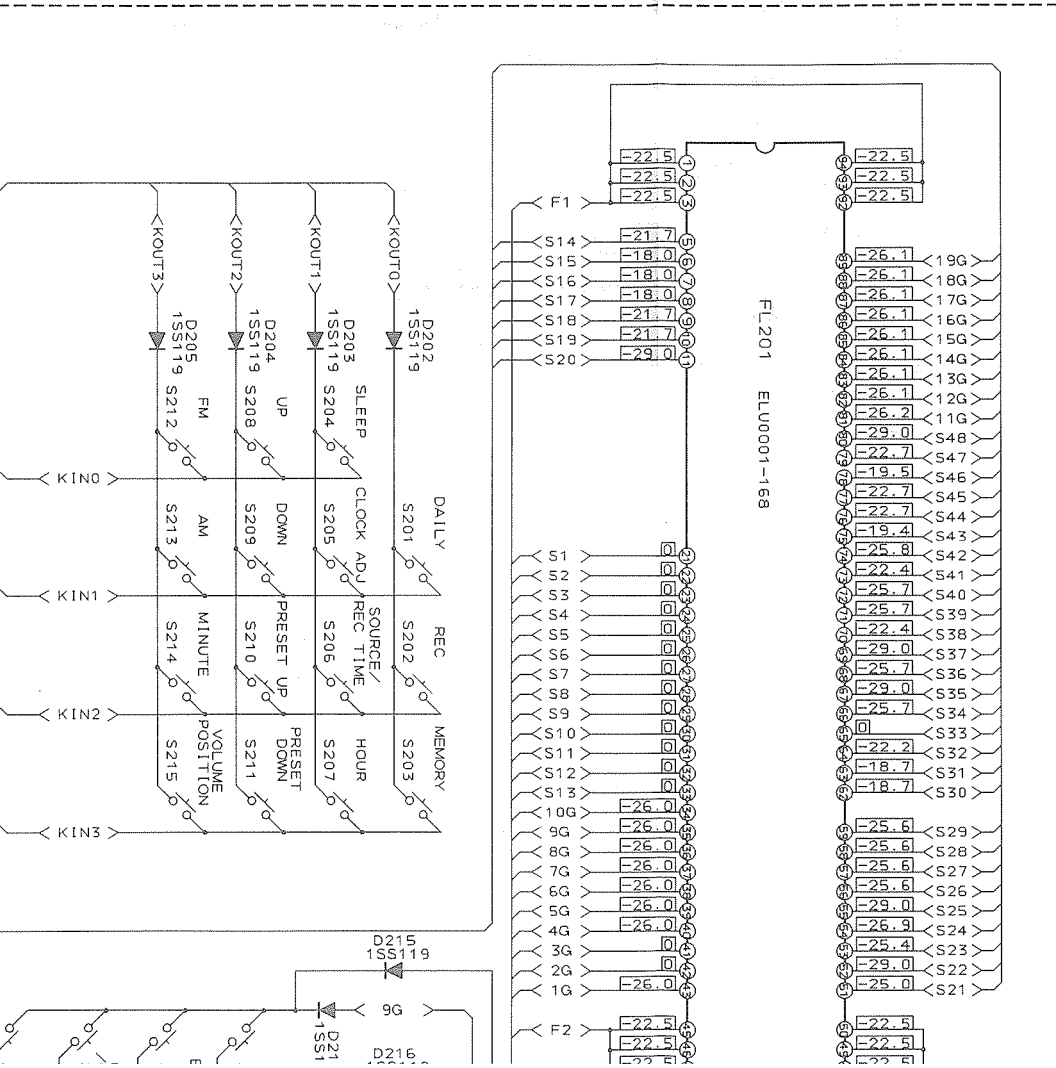

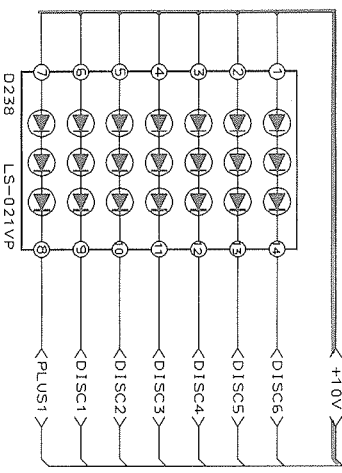
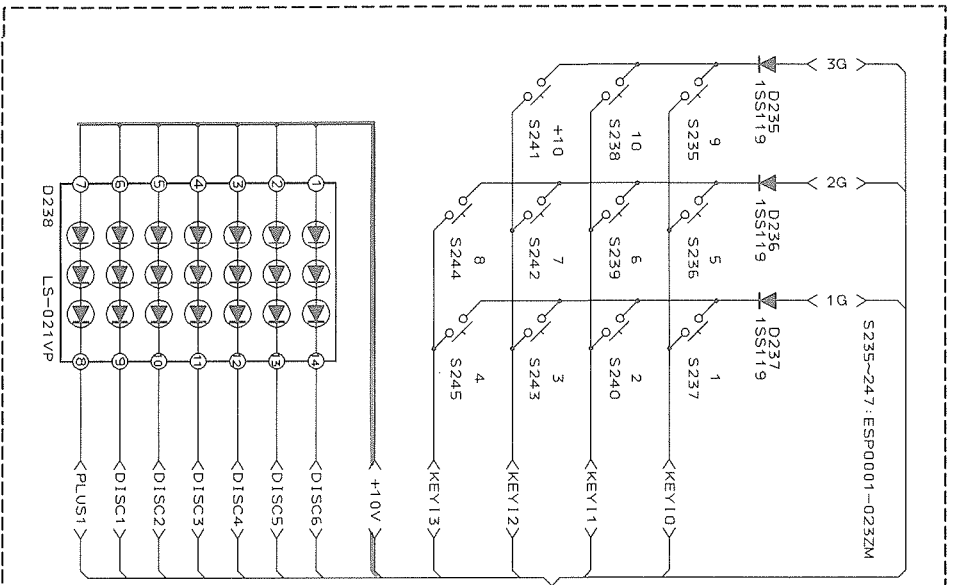
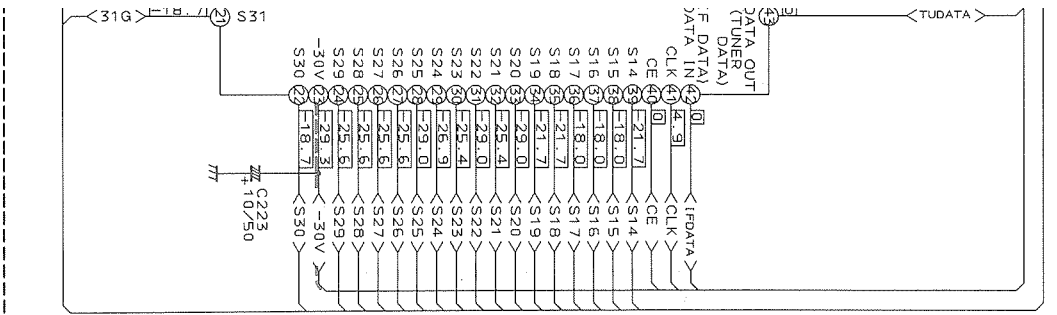

ENB-181-2

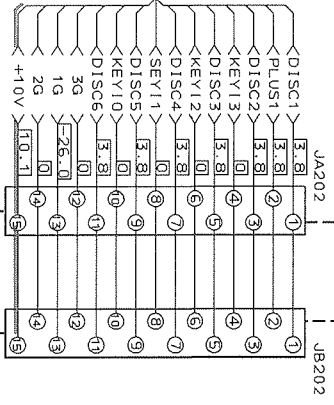

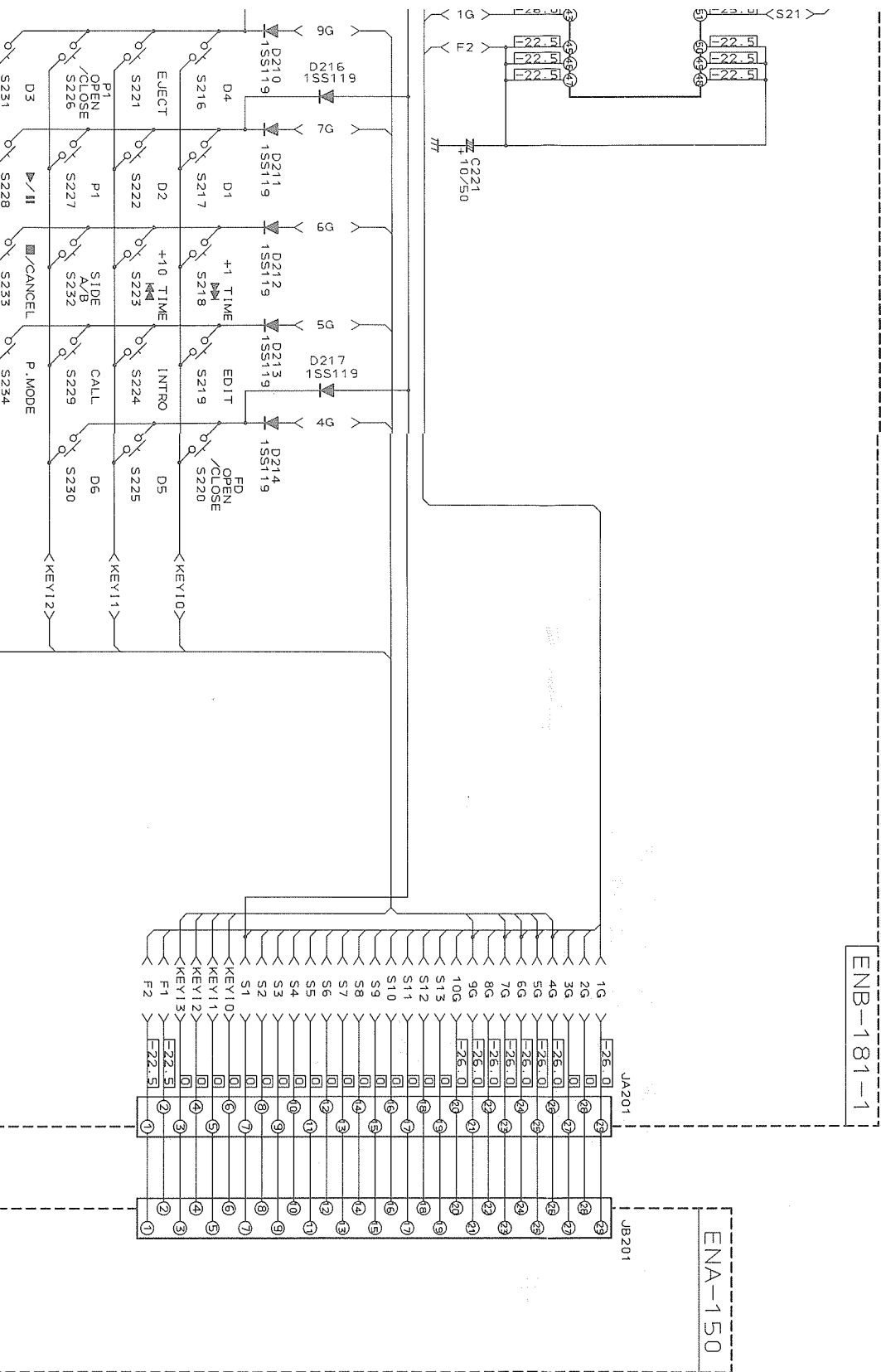

Printed Circuit Boards

■ CD, Tuner PCB (ENA-150)

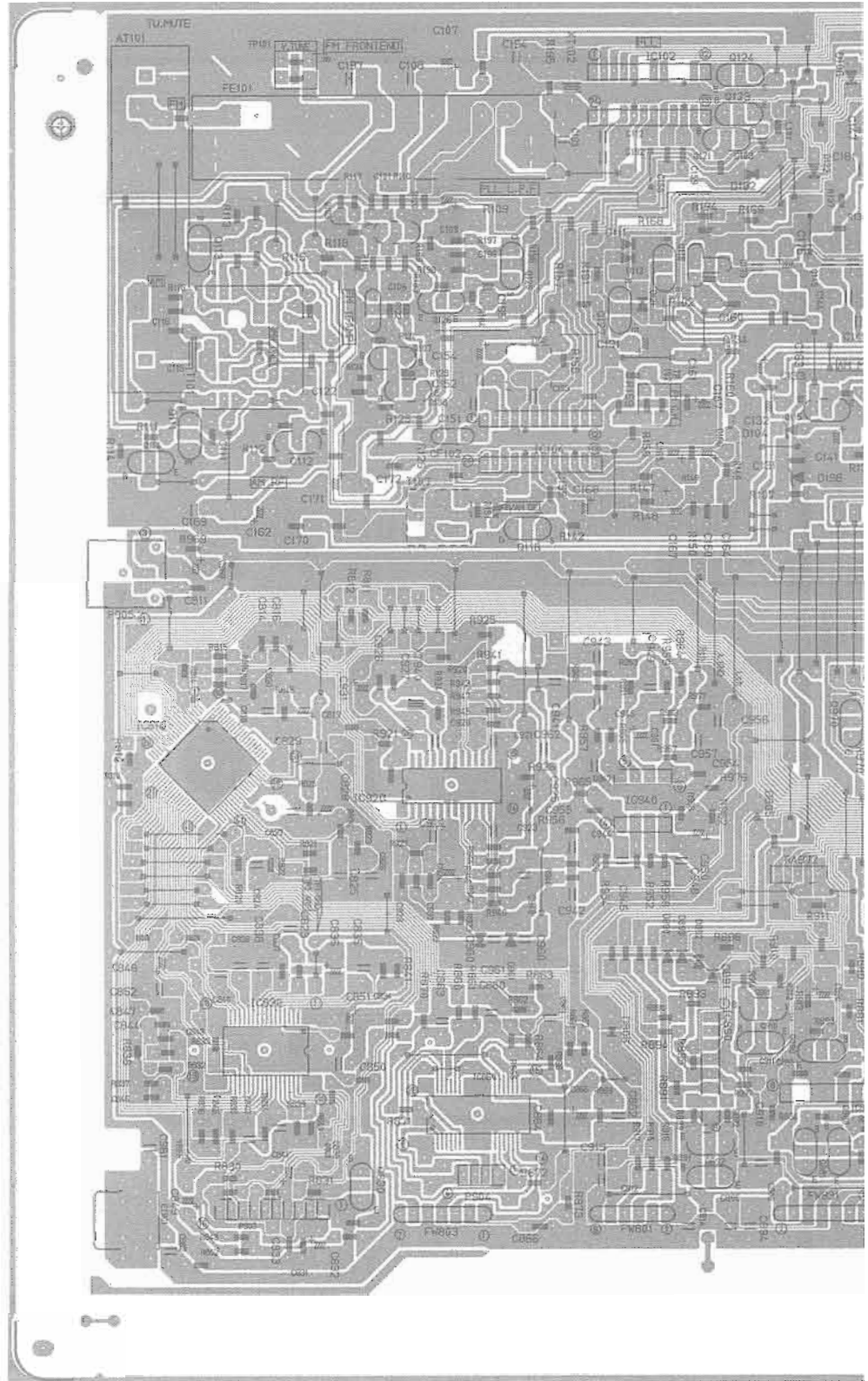

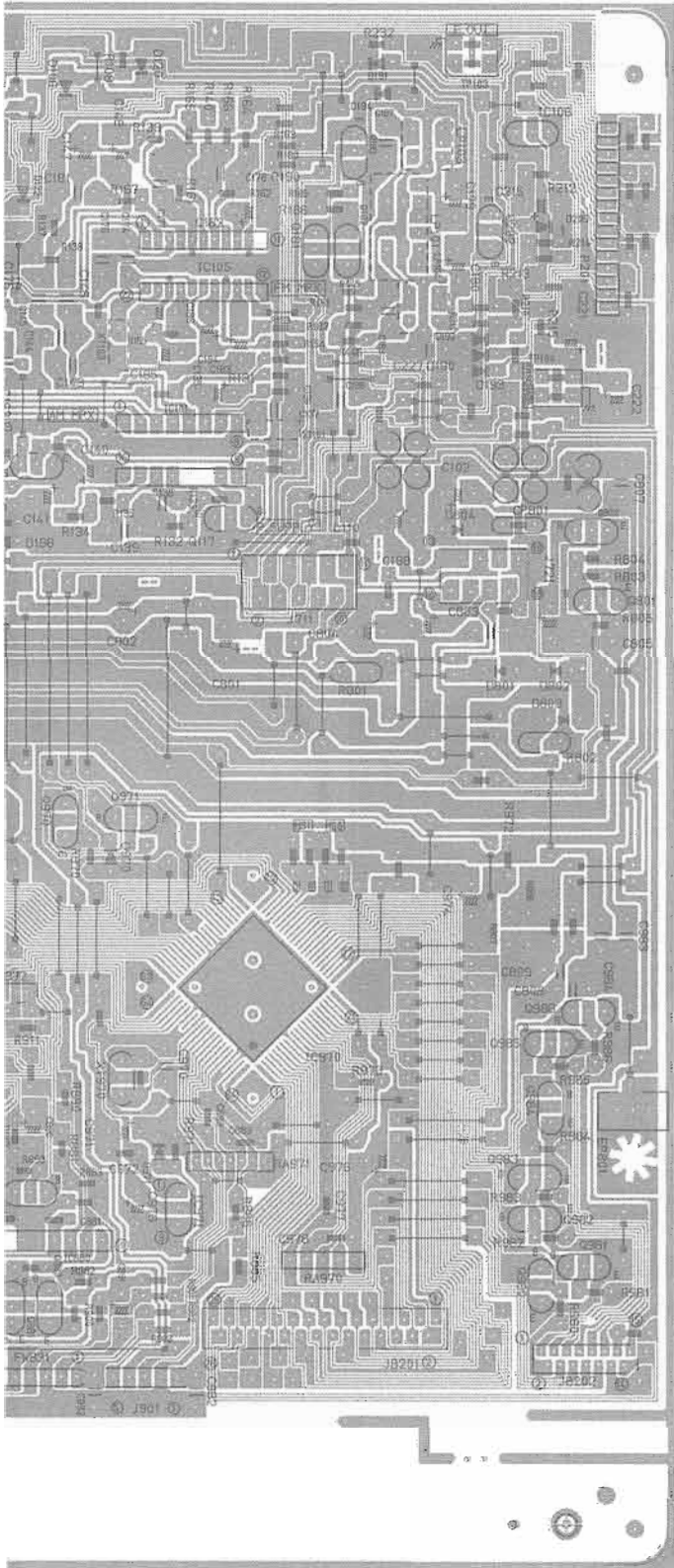

■ Front PCB (ENB-181)

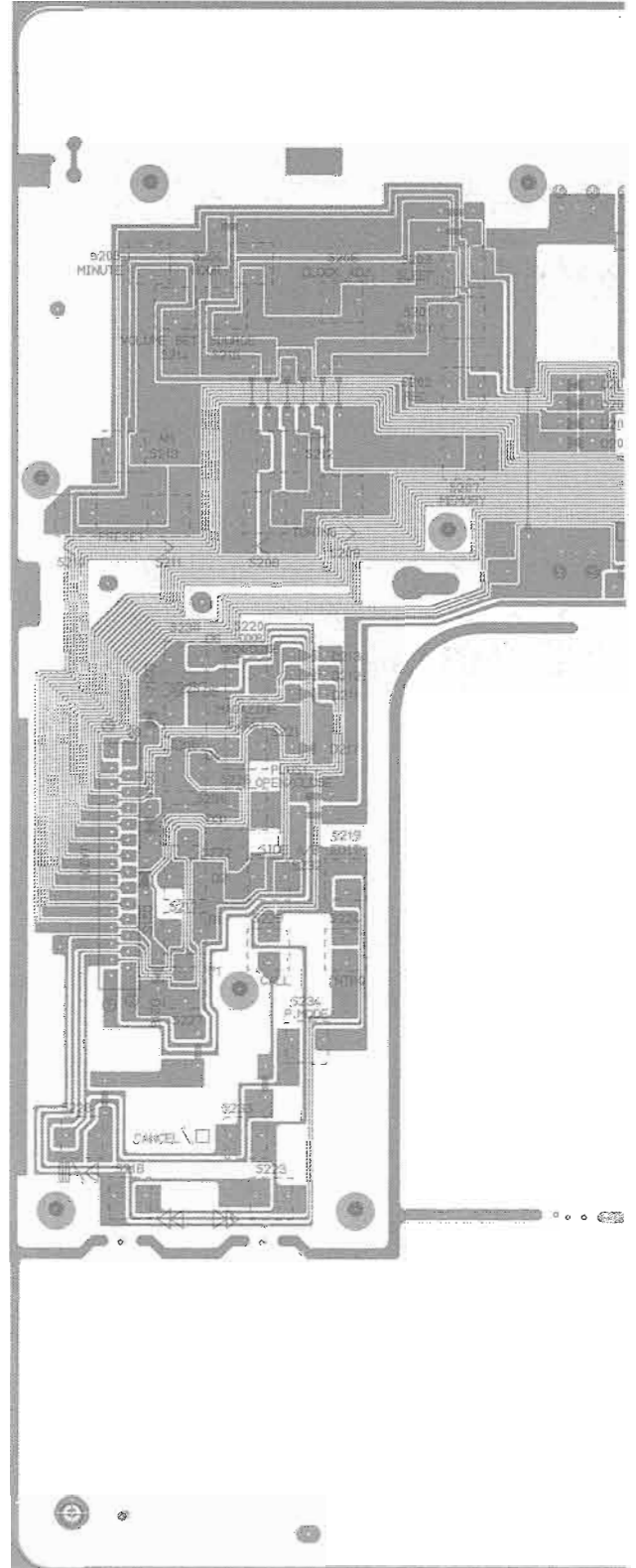

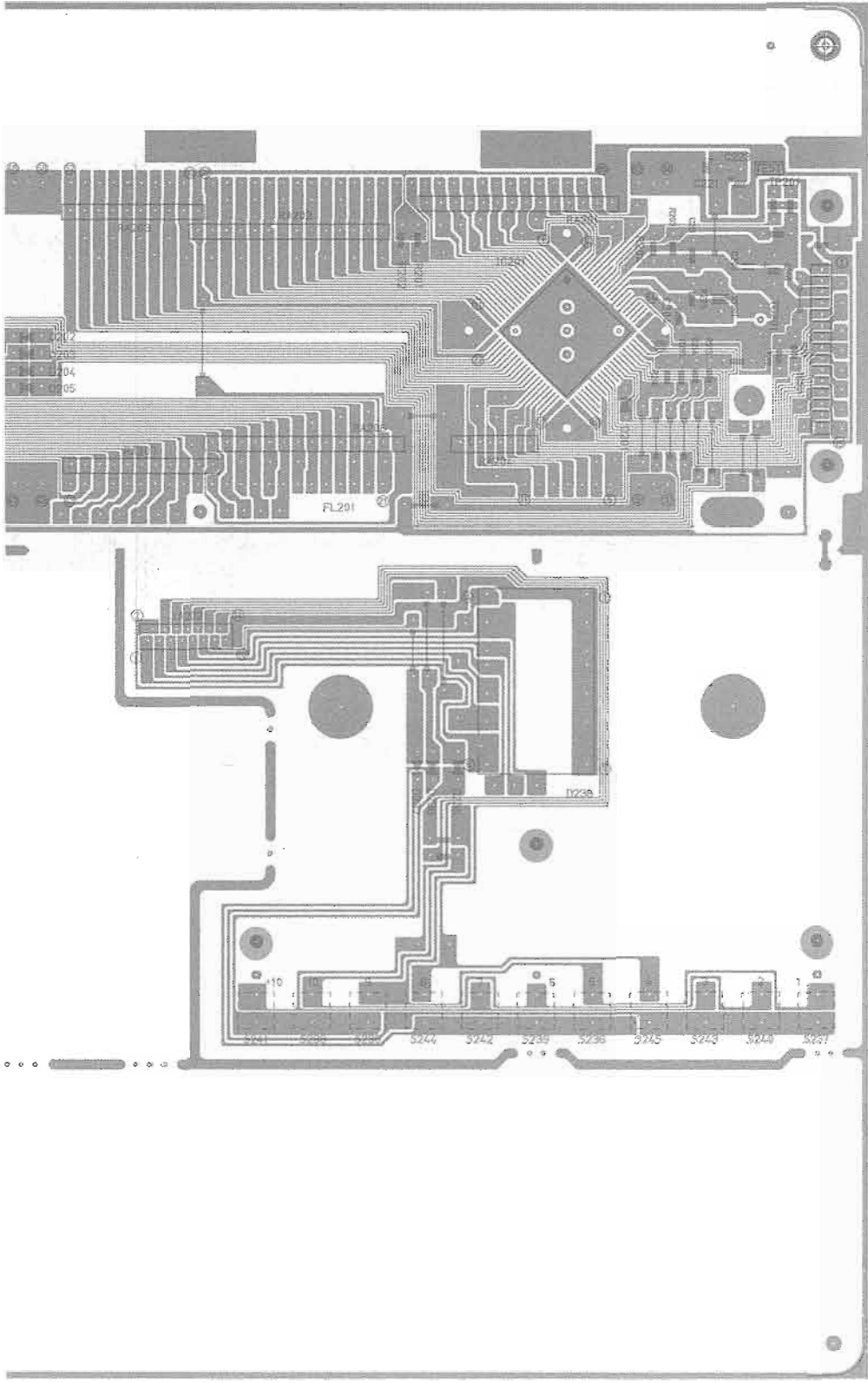

PARTS LIST

Note : All printed circuit boards and its assemblies are not available as service parts.

Composition

DX-M30BK

General Exploded View and Parts List	78
Cassette Mechanism Ass'y and Parts List	80
■ Grease Point	80
Printed Circuit Board Ass'y and Parts List	82
■ ENH-238 I Main, Deck & Amp. PC Board Ass'y	82
■ ENB-179 H Selector, System & Deck Controller PC Board Ass'y	87

XT-M30BK

General Exploded View and Parts List	92
CD Changer Ass'y and Parts List	94
■ Grease Point	94
Printed Circuit Board Ass'y and Parts List	97
■ ENA-150 B CD, Tuner PC Board Ass'y	97
■ ENB-181 B Front PC Board Ass'y	101
Accessories List	102
Packing Materials and Part Numbers	103

General Exploded View and Parts List

Symbol No.

M	1	M	M
---	---	---	---

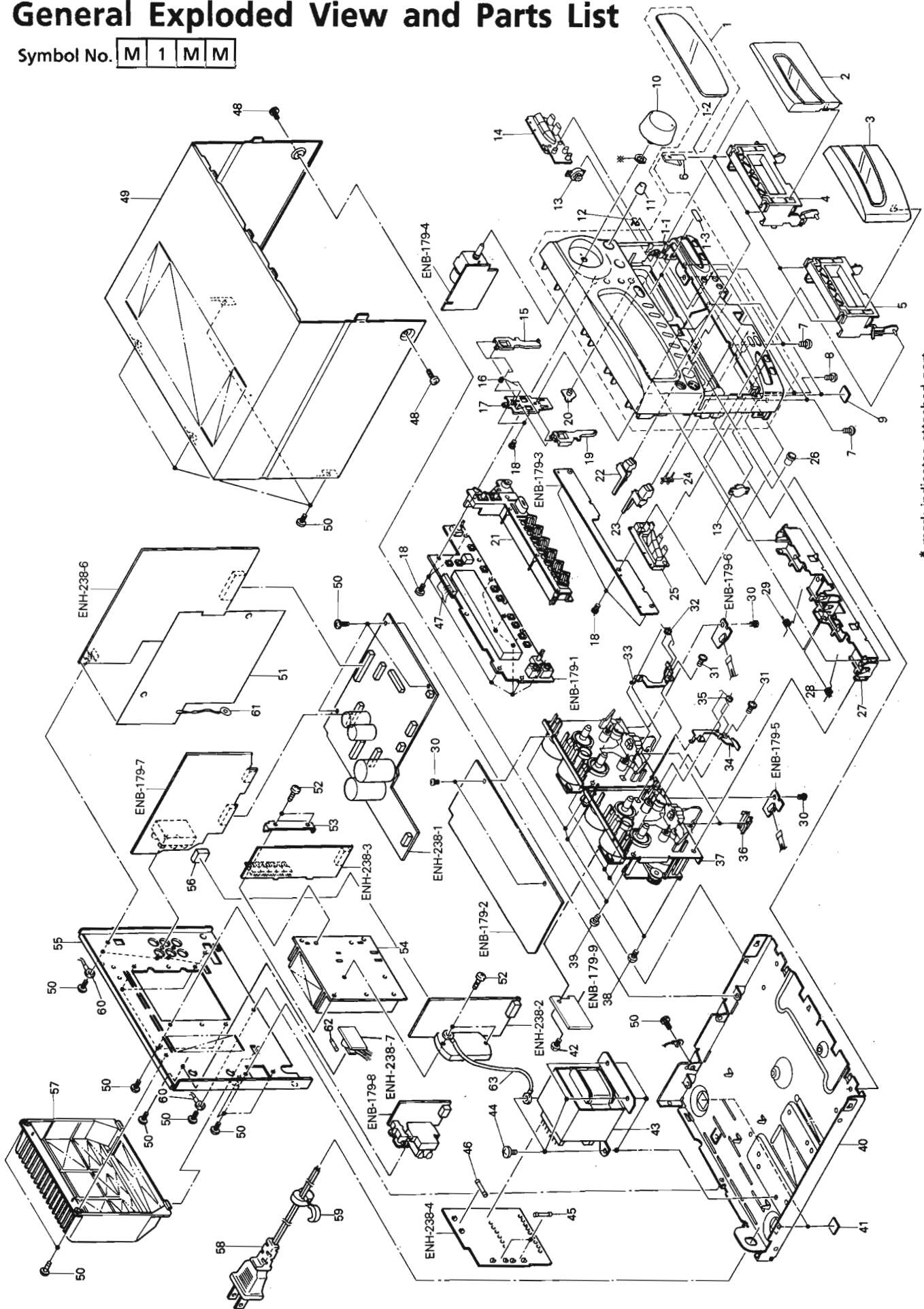

Parts List

Symbol No.

M	1	M	M
---	---	---	---

△	Item	Part Number	Part Name	Q'ty	Description	Areas
	1	EFP-DXM30BKU (S)	FRONT PANEL ASSY	1		
	1-1	E102808-002ST	FRONT PANEL	1		
	1-2	E208055-001	WINDOW SCREEN	1		
	1-3	E69777-003	REFLECTION PLATE	2		
	1-4	E406971-221	JVC MARK	1		
	2	E208049-002SA	CASSETTE LID ASSY	1	A MECHA	
	2-1	E208049-002	CASSETTE LID	1	A MECHA	
	2-2	E406971-221	JVC MARK	1	A MECHA	
	3	E208052-002	CASSETTE LID ASSY	1	B MECHA	
	4	E207972-002	CASSETTE HOLDER	1	A MECHA	
	5	E207973-002	CASSETTE HOLDER	1	B MECHA	
	6	E406713-001	CASSETTE SPRING	4		
	7	SBST3006M	SCREW	4		
	8	SBST3008Z	SCREW	2		
	9	E75896-001	SPACER	2	FRONT FOOT	
	10	E308673-002	VOLUME KNOB ASSY	1		
	11	E75737-013	KNOB	1		
	12	E407961-001	INDICATOR	1		
	13	E304434-005	DAMPER ASSY	2		
	14	E208046-001	PUSH BUTTON ASSY	1		
	15	E308682-001	EJECT LEVER	1	B MECHA	
	16	E407798-002	SPRING	1		
	17	E308683-002	EJECT GUIDE	1		
	18	SDSF2608Z	SCREW	13		
	19	E308681-001	EJECT LEVER	1	A MECHA	
	20	E407431-001SM	REMOTE PLATE	1		
	21	E208041-001	PUSH BUTTON ASSY	1		
	22	E308818-001	EJECT BUTTON	1	B MECHA	
	23	E308817-001	EJECT BUTTON	1	A MECHA	
	24	E407960-001	INDICATOR	1		
	25	E208043-001	PUSH BUTTON ASSY	1		
	26	E407233-003	KNOB	1		
	27	E207974-002	HOLDER BRACKET	1		
	28	E408058-001	HOLDER SPRING	1	A MECHA	
	29	E408122-001	HOLDER SPRING	1	B MECHA	
	30	SPST2604Z	SCREW	4		
	31	SBSF3006Z	SCREW	2		
	32	E407802-002	SPRING	1	B MECHA	
	33	E407800-001	EJECT SAFETY	1	B MECHA	
	34	E407799-001	EJECT SAFETY	1	A MECHA	
	35	E407801-002	SPRING	1	A MECHA	
	36	VKS3655-002	FPC HOLDER	2		
	37	-----	CASSETTE MECHANISM ASSY	1	SEE PAGE 80	
	38	SBSF3008C	SCREW	4		
	39	SBST3006C	SCREW	4		
	40	E102616-224	CHASSIS BASE	1		
	41	E75896-006	SPACER	2	REAR FOOT	
	42	SBSG3006N	SCREW	1		
△	43	ETP1100-49FA	POWER TRANSFORMER	1	T001	
	44	E65389-004	SPECIAL SCREW	4		
△	45	QMF51E2-1R25	FUSE	2	F101 , F102 (T1.25A / 250V)	
△	46	QMF51E2-2R0	FUSE	1	F001 (T2.0A / 250V)	
	47	EWR121K-27TT	FLAT WIRE	1	FC901	
	48	SDSG3006M	SCREW	2		
	49	E208069-002	METAL COVER	1		

⚠	Item	Part Number	Part Name	Q'ty	Description	Areas
	50	SBSG3008CC	SCREW	23		
	51	E308948-001	SHIELD PLATE	1	SP001	
	52	SBSG3014CC	SCREW	4		
	53	E406969-221	LEAF SPRING	1		
	54	E308819-001	HEAT SINK	1		
	55	E208057-010	REAR PANEL	1		
	56	E306805-119	SPACER	1		
	57	E207356-223	REAR COVER	1		
⚠	58	QMP7520-200	POWER CORD	1		
⚠	59	QHS3876-162	CORD STOPPER	1		
	60	52868-3	LUG	2	LU001 , LU002	
	61	EWT021-019	TERMINAL WIRE	1		
⚠	62	QMF51E2-1R0J1	FUSE	1	F002 (T1.0A / 250V)	
	63	EWT021-044K	TERMINAL WIRE	1	TW051	
	—	E61029-005	NUMBER LABEL	1		

⚠ SAFETY PARTS

Cassette Mechanism Ass'y and Parts List

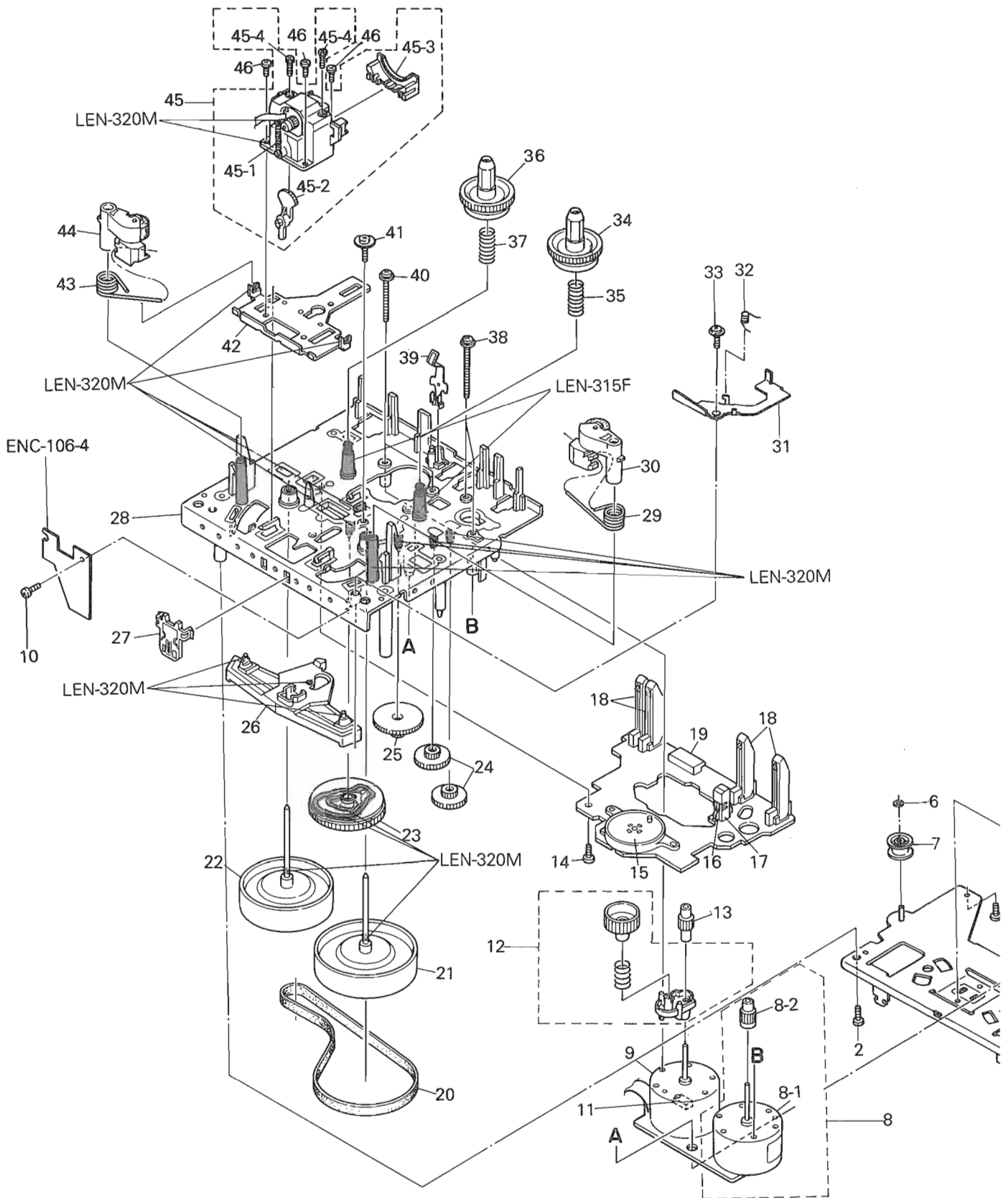

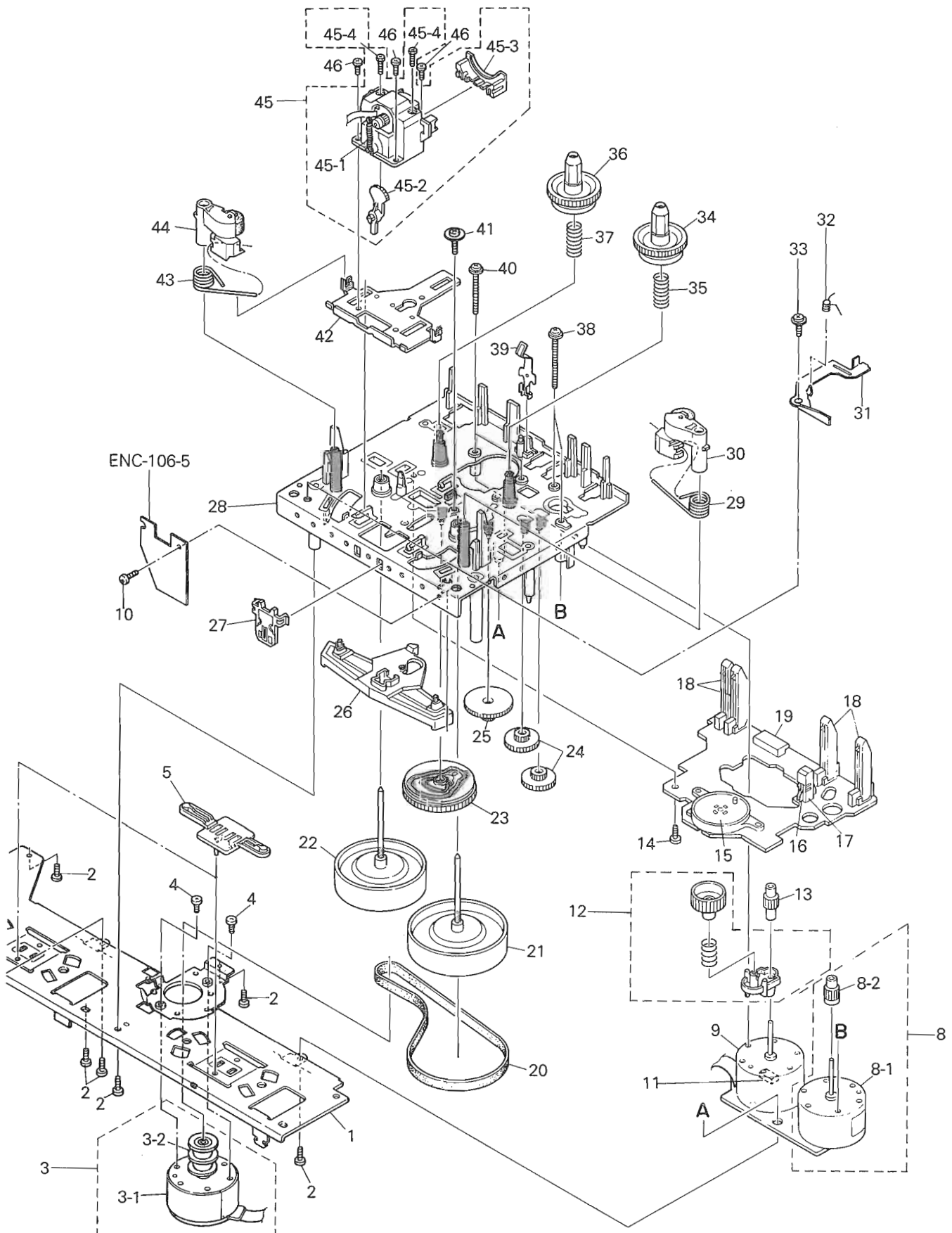

■ Parts List (Cassette Mechanism Ass'y)

Symbol No.

M	2	M	M
---	---	---	---

Item	Part Number	Part Name	Q'ty	Description	Areas
1	VKM3775-00A	FM BRACKET	1		
2	SDSF2608Z	SCREW	7		
3	MSI5U2LWA-SA1	DC MOTOR ASSY	1		
3-1	MSI-5U2LWA	MOTOR	1		
3-2	VKR4632-004	MOTOR PULLEY	1		
4	SPSP2603Z	SCREW	2		
5	VKS5327-004	PLATE	2		
6	WDL163525-4	WASHER	1		
7	VKR4631-002	IDLER PULLEY	1		
8	MSN5D257A-SA1	DC MOTOR ASSY	2		
8-1	MSN-5D257A	DC MOTOR	2		
8-2	VKS5433-001	MOTOR GEAR	2		
9	MMN-6F4RA38	DC MOTOR	2		
10	SDST2604Z	SCREW	2		
11	VMC0234-R08	CONNECTOR	2		
12	VKS5430-00B	FR ARM	2		
13	VKS5432-001	REEL MOTOR GEAR	2		
14	SDST2612Z	SCREW	2		
15	VKS3616-00A	CAM SWITCH	2		
16	DN6851-HI	IC	2		
17	VKS3630-001	IC HOLDER	2		
18	VSH1170-001	LEAF SWITCH	7		
19	VMC0234-R11	CONNECTOR	1	A MECHA	
	VMC0234-R14	CONNECTOR	1	B MECHA	
20	VKB3001-057	DRIVE BELT	1	A MECHA	
	VKB3001-058	DRIVE BELT	1	B MECHA	
21	VKF3184-00H	FLY WHEEL	2	RIGHT	
22	VKF3186-00H	FLY WHEEL	2	LEFT	
23	VKS2224-001	CONTROL CAM	2		
24	VKS5454-001	ACTUATOR GEAR	4		
25	VKS5455-001	ACTUATOR GEAR	2		
26	VKS3627-001	PINCHROLLER LEVER	2		
27	VKS3655-002	F.P.C. HOLDER	2		
28	VKS1134-00B	CHASSIS BASE	2		
29	VKW5045-003	PINCHROLLER SPRING	2	PINCHROLLER (RIGHT)	
30	VKP4227-00B	PINCHROLLER	2	RIGHT	
31	E407799-001	EJECT SAFETY	1	A MECHA	
	E407800-001	EJECT SAFETY	1	B MECHA	
32	E407801-002	SPRING	1	A MECHA	
	E407802-002	SPRING	1	B MECHA	
33	SBSF3008Z	SCREW	2		
34	VKS5428-00B	REEL	2		
35	VKW5043-001	TENSION SPRING	2		
36	VKS3617-002	REEL	2		
37	VKW5043-001	TENSION SPRING	2		
38	VKZ4705-002	SCREW	4		
39	VKY4670-001	CASSETTE SPRING	2		
40	VKZ4705-001	SCREW	2		
41	VKZ4708-001	SCREW	2		
42	VKM3632-001	HEAD BASE	2		
43	VKW5046-003	PINCHROLLER SPRING	2	PINCHROLLER (LEFT)	
44	VKP4229-00B	PINCHROLLER	2	LEFT	
45	VKS3626-00C	HEAD MOUNT	1	A MECHA	
	VKS3629-00C	HEAD MOUNT	1	B MECHA	
45-1	VKW5063-003	HEAD SPRING	2		
45-2	VKS3614-001	TURN GEAR	2		
45-3	VKS3654-001	HEAD MOUNT COVER	2		
45-4	VKZ4629-003	SCREW	4		
46	SDST2004Z	SCREW	6		

Printed Circuit Board Ass'y and Parts List

■ ENH-238 □ Main, Deck & Amp. PC Board Ass'y

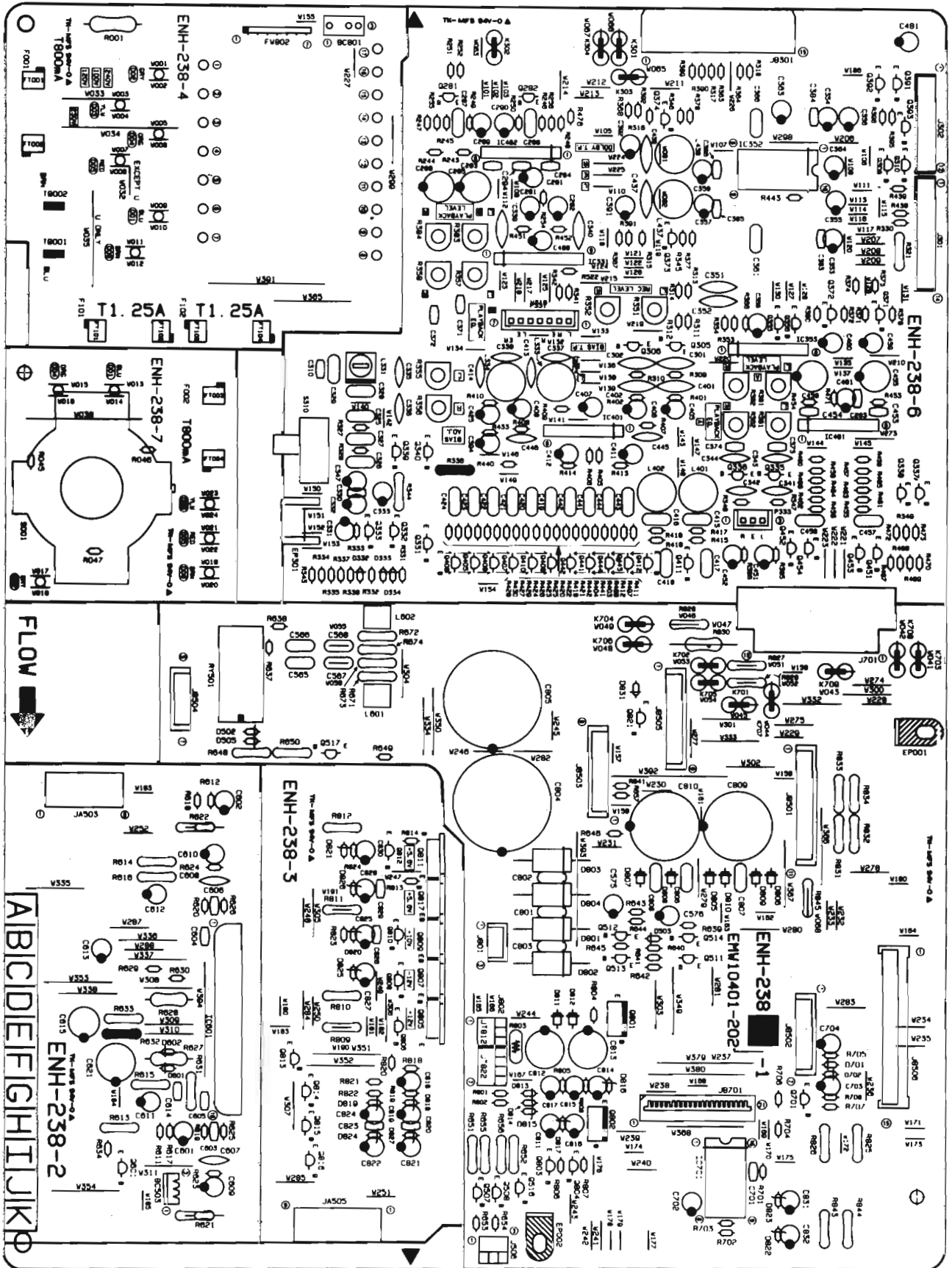

TRANSISTORS

Δ	ITEM	PART NUMBER	DESCRIPTION	AREA
	Q281	2SK301(P,Q)	F.E.T. MATSUSHITA	
	Q282	2SK301(P,Q)	F.E.T. MATSUSHITA	
	Q305	2SD2144S(VW)	SI.TRANSISTROHM	
	Q306	2SD2144S(VW)	SI.TRANSISTROHM	
	Q309	DTC144ES	DIGITAL TRAROHM	
	Q331	2SC1740S(R,S)	SI.TRANSISTROHM	U
	Q332	2SC1740S(R,S)	SI.TRANSISTROHM	
	Q333	2SC1740S(R,S)	SI.TRANSISTROHM	
	Q335	DTC144ES	DIGITAL TRAROHM	
	Q336	DTC144ES	DIGITAL TRAROHM	
	Q337	DTC144ES	DIGITAL TRAROHM	
	Q338	DTC144ES	DIGITAL TRAROHM	
	Q339	2SC1740S(R,S)	SI.TRANSISTROHM	
	Q340	2SC1740S(R,S)	SI.TRANSISTROHM	
	Q355	2SC1740S(R,S)	SI.TRANSISTROHM	
	Q356	2SC1740S(R,S)	SI.TRANSISTROHM	
	Q371	2SD2144S(VW)	SI.TRANSISTROHM	
	Q372	2SD2144S(VW)	SI.TRANSISTROHM	
	Q373	2SD2144S(VW)	SI.TRANSISTROHM	
	Q374	2SD2144S(VW)	SI.TRANSISTROHM	
	Q391	2SD2144S(VW)	SI.TRANSISTROHM	
	Q392	2SD2144S(VW)	SI.TRANSISTROHM	
	Q393	DTA144ES	DIGITAL TRAROHM	
	Q405	DTC144TS	DIGITAL TRAROHM	U
	Q406	DTC144TS	DIGITAL TRAROHM	U
	Q407	DTC144TS	DIGITAL TRAROHM	
	Q408	DTC144TS	DIGITAL TRAROHM	
	Q409	DTC144TS	DIGITAL TRAROHM	
	Q410	DTC144TS	DIGITAL TRAROHM	U
	Q411	DTC144TS	DIGITAL TRAROHM	
	Q412	DTC144TS	DIGITAL TRAROHM	
	Q441	DTC144TS	DIGITAL TRAROHM	
	Q442	DTC144TS	DIGITAL TRAROHM	
	Q443	DTC144TS	DIGITAL TRAROHM	
	Q444	DTC144TS	DIGITAL TRAROHM	
	Q451	2SK301(P,Q)	F.E.T. MATSUSHITA	
	Q452	2SK301(P,Q)	F.E.T. MATSUSHITA	
	Q453	2SK301(P,Q)	F.E.T. MATSUSHITA	
	Q454	2SK301(P,Q)	F.E.T. MATSUSHITA	
	Q507	2SD2144S(VW)	SI.TRANSISTROHM	
	Q508	2SD2144S(VW)	SI.TRANSISTROHM	
	Q511	2SC1740S(R,S)	SI.TRANSISTROHM	
	Q512	2SA733A(P,K)	SI.TRANSIST	
	Q513	2SC1740S(R,S)	SI.TRANSISTROHM	
	Q514	2SC1740S(R,S)	SI.TRANSISTROHM	
	Q516	DTA114TS	DIGITAL TRAROHM	
	Q517	2SC1740S(R,S)	SI.TRANSISTROHM	
	Q601	DTC144ES	DIGITAL TRAROHM	
	Q701	2SC1740S(R,S)	SI.TRANSISTROHM	
	Q801	2SB1357(E,F)	SI.TRANSISTROHM	
	Q802	2SD2037(E,F)	SI.TRANSISTROHM	
	Q803	DTC114ES	DIGITAL TRAROHM	
	Q804	DTC114YS	DIGITAL TRAROHM	
	Q805	2SD2061(E,F)	SI.TRANSIST	
	Q806	2SC1740S(R,S)	SI.TRANSISTROHM	
	Q807	2SB1187(E,F)	SI.TRANSIST	
	Q808	2SA564A(Q,R)	SI.TRANSIST	
	Q809	2SD2061(E,F)	SI.TRANSIST	
	Q810	2SC1740S(R,S)	SI.TRANSISTROHM	
	Q811	2SD2061(E,F)	SI.TRANSIST	
	Q812	2SC1740S(R,S)	SI.TRANSISTROHM	
	Q813	DTC144ES	DIGITAL TRAROHM	
	Q814	DTA144ES	DIGITAL TRAROHM	
	Q815	DTA144ES	DIGITAL TRAROHM	
	Q816	DTC144ES	DIGITAL TRAROHM	
	Q817	2SD2061(E,F)	SI.TRANSIST	
	Q821	DTA144ES	DIGITAL TRAROHM	

Δ ISAPRETTY PARTS

I. C. S.

Δ	ITEM	PART NUMBER	DESCRIPTION	AREA
	IC331	UPC1330HA	I.C(MONO-ANNEC	
	IC352	HA12136A	I.C(MONO-ANHITACHI	
	IC353	BA8221N	I.C(MONO-ANROHM	
	IC401	XRA15218N	I.C(MONO-AN	
	IC461	UPC1228HA	I.C(MONO-ANNEC	
	IC462	UPC1228HA	I.C(MONO-ANNEC	
	IC601	STK4161MK5V	I.C(HYBRID)SANYO	U
	IC701	KR1099CP	I.C(MONO-ANEXAR JAPAN	

Δ ISAPRETTY PARTS

DIODES

Δ	ITEM	PART NUMBER	DESCRIPTION	AREA
	D332	1SS119	SI.DIODE	
	D333	1SS119	SI.DIODE	U
	D334	1SS119	SI.DIODE	U
	D502	MT227JC	ZENER DIODEROHM	
	D503	1SS119	SI.DIODE	
	D505	MT2B.2JC	ZENER DIODEROHM	U
	D601	1SS119	SI.DIODE	
	D602	1SS119	SI.DIODE	
	D701	1SS119	SI.DIODE	
	D702	1SS119	SI.DIODE	
	Δ D801	30DL2FC	SI.DIODE NIHONINTER	U
	Δ D802	30DL2FC	SI.DIODE NIHONINTER	U
	Δ D803	30DL2FC	SI.DIODE NIHONINTER	U
	Δ D804	30DL2FC	SI.DIODE NIHONINTER	U
	D805	1SR139-200	SI.DIODE ROHM	
	D806	1SR139-200	SI.DIODE ROHM	
	D807	1SR139-200	SI.DIODE ROHM	
	D808	1SR139-200	SI.DIODE ROHM	
	D809	1SR139-200	SI.DIODE ROHM	
	D810	1SR139-200	SI.DIODE ROHM	
	D811	1SR139-200	SI.DIODE ROHM	
	D812	1SR139-200	SI.DIODE ROHM	
	D813	1SS119	SI.DIODE	
	D814	1SS119	SI.DIODE	
	D815	MT25.1JC	ZENER DIODEROHM	
	D816	MT230JC	ZENER DIODEROHM	
	D817	MT26.2JC	ZENER DIODEROHM	
	D818	MT213JC	ZENER DIODEROHM	
	D819	MT213JC	ZENER DIODEROHM	
	D820	MT211JC	ZENER DIODEROHM	
	D821	RD6.8JSB3	ZENER DIODENEK	U
	D822	MT25.1JB	ZENER DIODEROHM	
	D823	MT25.1JB	ZENER DIODEROHM	
	D824	MT213JC	ZENER DIODEROHM	
	D825	MT212JC	ZENER DIODEROHM	
	D826	MT26.8JC	ZENER DIODEROHM	
	D827	MT213JC	ZENER DIODEROHM	
	D831	1SS119	SI.DIODE	

Δ ISAPRETTY PARTS

CAPACITORS

Δ	ITEM	PART NUMBER	DESCRIPTION	AREA
	C281	QETB1HM-225	2.2MF 50V E.CAPACITO R	
	C282	QETB1HM-225	2.2MF 50V E.CAPACITO R	
	C283	QCB1HK-101	100PF 50V CERAMIC	U
	C284	QCB1HK-101	100PF 50V CERAMIC	U
	C285	QETB1AM-107	100MF 10V AL E.CAPAC IT	
	C286	QETB1AM-107	100MF 10V AL E.CAPAC IT	
	C287	QFLB1HJ-822	8200PF 50V MYLAR CAPA CI	
	C288	QFLB1HJ-822	8200PF 50V MYLAR CAPA CI	
	C289	QEK51HM-105G	1MF 50V AL E.CAPAC IT	
	C290	QEK51HM-105G	1MF 50V AL E.CAPAC IT	
	C291	QETB1CM-107	100MF 16V AL E.CAPAC IT	
	C301	QCY21HK-122	1200PF 50V CERAMIC	
	C302	QCY21HK-122	1200PF 50V CERAMIC	
	C325	QFLB1HJ-332	3300PF 50V MYLAR CAPA CI	
	C326	QFLB1HJ-332	3300PF 50V MYLAR CAPA CI	
	C327	QFLB1HJ-682	6800PF 50V MYLAR CAPA CI	
	C328	QFLB1HJ-183	0.018MF 50V MYLAR CAPA CI	
	C329	QFPB1HG-472	4700PF 50V POLY	
	C331	QETB1HM-105	1MF 50V AL E.CAPAC IT	
	C332	QETB1HM-105	1MF 50V AL E.CAPAC IT	
	C333	QETB1EM-106	10MF 25V AL E.CAPAC IT	
	C335	QCS21HJ-101	100PF 50V CERAMIC	
	C336	QCS21HJ-101	100PF 50V CERAMIC	
	C337	QCS21HJ-101	100PF 50V CERAMIC	
	C338	QCS21HJ-101	100PF 50V CERAMIC	
	C339	QCY21HK-152	1500PF 50V CERAMIC	
	C340	QCY21HK-152	1500PF 50V CERAMIC	
	C341	QCS21HJ-331	330PF 50V CER.CAPACI TO	
	C342	QCS21HJ-331	330PF 50V CER.CAPACI TO	
	C343	QCY21HK-122	1200PF 50V CERAMIC	
	C344	QCY21HK-122	1200PF 50V CERAMIC	
	C347	QETB1CM-107	100MF 16V AL E.CAPAC IT	
	C351	QCF21HP-473	0.047MF 50V CERAMIC	
	C352	QCF21HP-473	0.047MF 50V CERAMIC	
	C353	QETB1HM-105	1MF 50V AL E.CAPAC IT	
	C354	QETB1HM-105	1MF 50V AL E.CAPAC IT	
	C355	QETB1HM-105	1MF 50V AL E.CAPAC IT	
	C356	QETB1HM-105	1MF 50V AL E.CAPAC IT	
	C357	QETB1EM-106	10MF 25V AL E.CAPAC IT	
	C358	QETB1EM-106	10MF 25V AL E.CAPAC IT	
	C359	QETB1EM-476	47MF 25V AL E.CAPAC IT U	
	C361	QFV81HJ-224	0.22MF 50V THIN FILM CA	
	C363	QETB1HM-475	4.7MF 50V AL E.CAPAC IT	
	C364	QETB1CM-107	100MF 16V AL E.CAPAC IT	
	C366	QFV81HJ-224	0.22MF 50V THIN FILM CA	

Δ ISAPRETTY PARTS

RESISTORS

Δ	ITEM	PART NUMBER	DESCRIPTION	AREA
	R381	QVPA601-201A	200 TRIMMER RES	SI
	R382	QVPA601-201A	200 TRIMMER RES	SI
	R383	QVPA601-201A	200 TRIMMER RES	SI
	R384	QVPA601-201A	200 TRIMMER RES	SI
	R385	QRD167J-470	47 1/6W CARBON RES	IS
	R386	QRD167J-470	47 1/6W CARBON RES	IS
	R389	QRD167J-221	220 1/6W CARBON RES	IS
	R390	QRD167J-221	220 1/6W CARBON RES	IS
	R391	QRD167J-562	5.6K 1/6W CARBON RES	IS
	R392	QRD167J-562	5.6K 1/6W CARBON RES	IS
	R395	QRD167J-103	10K 1/6W CARBON RES	IS
	R396	QRD167J-103	10K 1/6W CARBON RES	IS
	R401	QRD167J-393	39K 1/6W CARBON RES	IS
	R402	QRD167J-393	39K 1/6W CARBON RES	IS
	R403	QRD167J-332	3.3K 1/6W CARBON RES	IS
	R404	QRD167J-332	3.3K 1/6W CARBON RES	IS
	R405	QRD167J-683	68K 1/6W CARBON RES	IS
	R406	QRD167J-683	68K 1/6W CARBON RES	IS
	R407	QRD167J-153	15K 1/6W CARBON RES	IS
	R408	QRD167J-153	15K 1/6W CARBON RES	IS
	R409	QRD167J-153	15K 1/6W CARBON RES	IS
	R410	QRD167J-153	15K 1/6W CARBON RES	IS
	R411	QRD167J-332	3.3K 1/6W CARBON RES	IS
	R412	QRD167J-332	3.3K 1/6W CARBON RES	IS
	R413	QRD167J-182	1.8K 1/6W CARBON RES	IS
	R414	QRD167J-182	1.8K 1/6W CARBON RES	IS
	R415	QRD161J-181	180 1/6W CARBON RES	IS
	R416	QRD161J-181	180 1/6W CARBON RES	IS
	R417	QRD161J-181	180 1/6W CARBON RES	IS
	R418	QRD161J-181	180 1/6W CARBON RES	IS
	R419	QRD161J-242	2.4K 1/6W CARBON RES	IS U
	R420	QRD161J-242	2.4K 1/6W CARBON RES	IS U
	R421	QRD161J-202	2K 1/6W CARBON RES	IS U
	R422	QRD161J-202	2K 1/6W CARBON RES	IS U
	R423	QRD167J-102	1K 1/6W CARBON RES	IS
	R424	QRD167J-102	1K 1/6W CARBON RES	IS
	R427	QRD167J-151	150 1/6W CARBON RES	IS U
	R428	QRD167J-151	150 1/6W CARBON RES	IS U
	R429	QRD167J-162	1.6K 1/6W CARBON RES	IS U
	R430	QRD167J-162	1.6K 1/6W CARBON RES	IS U
	R433	QRD167J-221	220 1/6W CARBON RES	IS
	R438	QRD167J-103	10K 1/6W CARBON RES	IS
	R440	QRD167J-221	220 1/6W CARBON RES	IS
	R441	QRD161J-202	2K 1/6W CARBON RES	IS
	R442	QRD161J-202	2K 1/6W CARBON RES	IS
	R443	QRD161J-183	18K 1/6W CARBON RES	IS
	R451	QRD167J-470	47 1/6W CARBON RES	IS
	R452	QRD167J-470	47 1/6W CARBON RES	IS
	R453	QRD167J-470	47 1/6W CARBON RES	IS
	R454	QRD167J-470	47 1/6W CARBON RES	IS
	R455	QRD167J-334	330K 1/6W CARBON RES	IS
	R456	QRD167J-334	330K 1/6W CARBON RES	IS
	R457	QRD167J-362	3.6K 1/6W CARBON RES	IS
	R458	QRD167J-362	3.6K 1/6W CARBON RES	IS
	R459	QRD167J-222	2.2K 1/6W CARBON RES	IS
	R460	QRD167J-222	2.2K 1/6W CARBON RES	IS
	R461	QRD167J-332	3.3K 1/6W CARBON RES	IS
	R462	QRD167J-332	3.3K 1/6W CARBON RES	IS
	R463	QRD167J-682	6.8K 1/6W CARBON RES	IS
	R464	QRD167J-682	6.8K 1/6W CARBON RES	IS
	R465	QRD167J-223	22K 1/6W CARBON RES	IS
	R466	QRD167J-223	22K 1/6W CARBON RES	IS
	R467	QRD161J-105	1M 1/6W CARBON RES	IS
	R468	QRD161J-105	1M 1/6W CARBON RES	IS
	R469	QRD161J-105	1M 1/6W CARBON RES	IS
	R470	QRD161J-105	1M 1/6W CARBON RES	IS
	R471	QRD167J-471	470 1/6W CARBON RES	IS
	R472	QRD167J-472	4.7K 1/6W CARBON RES	IS
	R473	QRD167J-472	4.7K 1/6W CARBON RES	IS
	R476	QRD167J-472	4.7K 1/6W CARBON RES	IS
	R497	QRD167J-471	470 1/6W CARBON RES	IS
	R498	QRD167J-471	470 1/6W CARBON RES	IS
	R522	QRD167J-221	220 1/6W CARBON RES	IS
	R611	QRD167J-102	1K 1/6W CARBON RES	IS
	R612	QRD167J-102	1K 1/6W CARBON RES	IS
Δ	R613	QRD14CJ-272S	2.7K 1/4W UNF. CARBON R	R
Δ	R614	QRD14CJ-272S	2.7K 1/4W UNF. CARBON R	R
Δ	R615	QRD14CJ-272S	2.7K 1/4W UNF. CARBON R	R
Δ	R616	QRD14CJ-272S	2.7K 1/4W UNF. CARBON R	R
	R617	QRD167J-474	470K 1/6W CARBON RES	IS
	R618	QRD167J-474	470K 1/6W CARBON RES	IS
	R619	QRD167J-563	56K 1/6W CARBON RES	IS
	R620	QRD167J-563	56K 1/6W CARBON RES	IS
	R621	ERD141J-391S	390 1/4W CARBON	U
	R622	ERD141J-391S	390 1/4W CARBON	U
	R623	QRD167J-563	56K 1/6W CARBON RES	IS
	R624	QRD167J-563	56K 1/6W CARBON RES	IS
	R625	QRD167J-391	390 1/6W CARBON RES	IS U
	R626	QRD167J-391	390 1/6W CARBON RES	IS U
Δ	R627	QRX012J-R22AM	0.22 1W METAL FILM R	R
Δ	R628	QRX012J-R22AM	0.22 1W METAL FILM R	R
	R629	QRD161J-272	2.7K 1/6W CARBON RES	IS
	R630	QRD161J-272	2.7K 1/6W CARBON RES	IS
Δ	R631	QR20077-100	10 1/4W FUSIBLE RE	SI U
Δ	R632	QR20077-100	10 1/4W FUSIBLE RE	SI U

Δ : ISAFETY PARTS

RESISTORS

Δ	ITEM	PART NUMBER	DESCRIPTION	AREA
Δ	R633	QRD14CJ-101S	100 1/4W UNF. CARBON	R U
	R634	QRD167J-103	10K 1/6W CARBON RES	IS
	R637	QRD167J-104	100K 1/6W CARBON RES	IS
	R638	QRD167J-823	82K 1/6W CARBON RES	IS
	R639	QRD161J-333	33K 1/6W CARBON RES	IS
	R640	QRD167J-103	10K 1/6W CARBON RES	IS
	R641	QRD167J-473	47K 1/6W CARBON RES	IS
	R642	QRD167J-222	2.2K 1/6W CARBON RES	IS
	R643	QRD167J-103	10K 1/6W CARBON RES	IS
	R644	QRD167J-104	100K 1/6W CARBON RES	IS
	R645	QRD167J-473	47K 1/6W CARBON RES	IS
	R646	QRD167J-103	10K 1/6W CARBON RES	IS
Δ	R648	QR20077-331	330 1/4W FUSIBLE RE	SI U
	R649	QRD167J-152	1.5K 1/6W CARBON RES	IS
Δ	R650	QRD14CJ-331S	330 1/4W UNF. CARBON R	R U
Δ	R651	QRD14CJ-821S	820 1/4W UNF. CARBON R	R U
Δ	R652	QRD14CJ-821S	820 1/4W UNF. CARBON R	R U
	R653	QRD167J-473	47K 1/6W CARBON RES	IS
	R654	QRD167J-473	47K 1/6W CARBON RES	IS
Δ	R655	QRD14CJ-331S	330 1/4W UNF. CARBON R	R
Δ	R656	QRD14CJ-331S	330 1/4W UNF. CARBON R	R
Δ	R657	QRD167J-562	5.6K 1/6W CARBON RES	IS U
Δ	R671	QRD14CJ-100S	10 1/4W UNF. CARBON R	R
Δ	R672	QRD14CJ-100S	10 1/4W UNF. CARBON R	R
Δ	R673	QRD14CJ-100S	10 1/4W UNF. CARBON R	R
Δ	R674	QRD14CJ-100S	10 1/4W UNF. CARBON R	R
	R701	QRD167J-152	1.5K 1/6W CARBON RES	IS
	R702	QRD167J-223	22K 1/6W CARBON RES	IS
	R703	QRD167J-223	22K 1/6W CARBON RES	IS
	R704	QRD167J-562	5.6K 1/6W CARBON RES	IS
	R705	QRD167J-562	5.6K 1/6W CARBON RES	IS
	R706	QRD167J-103	10K 1/6W CARBON RES	IS U
	R707	QRD167J-104	100K 1/6W CARBON RES	IS
	R708	QRD167J-222	2.2K 1/6W CARBON RES	IS
	R801	QRD167J-103	10K 1/6W CARBON RES	IS
Δ	R802	QRD167J-103	10K 1/6W CARBON RES	IS
Δ	R803	PTH61G25AR4R7M	FUSIBLE RE	SI
	R804	QRD167J-332	3.3K 1/6W CARBON RES	IS
	R805	QRD167J-104	100K 1/6W CARBON RES	IS
	R806	QRD167J-103	10K 1/6W CARBON RES	IS
	R807	QRD167J-102	1K 1/6W CARBON RES	IS
	R808	QRD167J-223	22K 1/6W CARBON RES	IS
Δ	R810	QRD14CJ-1R5S	1.5 1/4W UNF. CARBON R	R U
Δ	R812	QRD14CJ-1R0S	1 1/4W CARBON RES	IS U
Δ	R813	QRD161J-101	100 1/6W CARBON RES	IS
	R814	QRD161J-101	100 1/6W CARBON RES	IS
	R818	QRD167J-152	1.5K 1/6W CARBON RES	IS
	R819	QRD167J-152	1.5K 1/6W CARBON RES	IS
	R820	QRD167J-153	15K 1/6W CARBON RES	IS
	R821	QRD167J-153	15K 1/6W CARBON RES	IS
	R822	QRD167J-222	2.2K 1/6W CARBON RES	IS
	R823	QRD167J-222	2.2K 1/6W CARBON RES	IS
	R824	QRD167J-222	2.2K 1/6W CARBON RES	IS
Δ	R825	QRD14CJ-331S	330 1/4W UNF. CARBON R	R
Δ	R826	QRD14CJ-331S	330 1/4W UNF. CARBON R	R
Δ	R831	QR20077-100	10 1/4W FUSIBLE RE	SI U
Δ	R832	QR20077-100	10 1/4W FUSIBLE RE	SI U
Δ	R833	QR20077-100	10 1/4W FUSIBLE RE	SI U
Δ	R834	QR20077-100	10 1/4W FUSIBLE RE	SI U
	R841	QRD161J-333	33K 1/6W CARBON RES	IS
Δ	R843	QRD14CJ-4R7S	4.7 1/4W UNF. CARBON R	R U
Δ	R844	QRD14CJ-4R7S	4.7 1/4W UNF. CARBON R	R U

Δ : ISAFETY PARTS

OTHERS

Δ	ITEM	PART NUMBER	DESCRIPTION	AREA
	J301	EMV5142-914	CONNECT TERMINAL (14PIN) to Deck Control CB	
	J302	EMV5142-912	CONNECT TERMINAL (12PIN) to Deck Control CB	
	J506	EMV7122-103	CONNECT TERMINAL (3PIN) to Headphone	
	J701	EMV7127-019	CONNECT TERMINAL (19PIN) System Connector	
	J801	EMV5133-003	CONNECT TERMINAL (3PIN) from P. Transformer	
	L331	ENZ6002-012	OSCILLATOR COIL	
	L333	EQL2106-223	INDUCTOR	
	L334	EQL2106-223	INDUCTOR	
	L401	EQL2106-562	INDUCTOR	
	L402	EQL2106-562	INDUCTOR	
	L437	EQL2106-223	INDUCTOR	U
	L438	EQL2106-223	INDUCTOR	U
	L601	EQL0001-R45	INDUCTOR	
	L602	EQL0001-R45	INDUCTOR	
	P331	EMV5133-007K	PLUG(7PIN) Deck CB : from B Mecha.	U
	P333	EMV5133-003	CONNECT TERMINAL (3PIN) Deck CB : from A Mecha.	U
Δ	S001	QSR0085-018	SELECT SWITCH	U
	BC503	EWS293-0125	SOCKET WIRE (3PIN) Amp. CB	
	BC801	EWS243-066	SOCKET WIRE ASSY (3PIN) Trans. CB	
	EP001	EMZ4002-001Z	EARTH PLATE	

Δ : ISAFETY PARTS

OTHERS

△	ITEM	PART NUMBER	DESCRIPTION	AREA
	EP301	E70225-001	EARTH PLATE	
	FL001	E67132-T2R0	FUSE LABEL	U
	FL002	E67132-T1R0	T1R0 FUSE LABEL	U
	FS641	E3400-431	FELT SPACER	U
	FT001	VMZ0087-001	FUSE CLIP	
	FT002	VMZ0087-001	FUSE CLIP	
	FT003	VMZ0087-001	FUSE CLIP	U
	FT004	VMZ0087-001	FUSE CLIP	U
	FT101	VMZ0087-001	FUSE CLIP	
	FT102	VMZ0087-001	FUSE CLIP	
	FT103	VMZ0087-001	FUSE CLIP	
	FT104	VMZ0087-001	FUSE CLIP	
	FW802	EWR37B-10LST	FLAT WIRE ASSY(7PIN) Trans. CB	U
	JA503	EMV7125-008R	MALE CONNECTOR(8PIN) Amp. CB	
	JA505	EMV7125-009R	CONNECT TERMINAL (9PIN) Regulator CB	
	JB301	EMV7140-L15R	CONNECT TERMINAL (15PIN) Deck CB ; to J506	
	JB501	EMV5125-011	MALE CONNECTOR(11PIN) to Input / Selector CB	
	JB502	EMV5125-007	MALE CONNECTOR(7PIN) to Input / Selector CB	
	JB503	EMV5125-008	MALE CONNECTOR(8PIN) to Amp. CB	
	JB504	EMV5125-005	CONNECT TERMINAL (5PIN) to Speaker CB	
	JB505	EMV5125-009	CONNECT TERMINAL (9PIN) to Regulator CB	
	JB506	EMV5140-015	CONNECT TERMINAL (15PIN) to JB301	
	JB701	EMV7123-021	CONNECT TERMINAL (21PIN) Front CB	
	JT812	EMV7122-103	CONNECT TERMINAL (3PIN) a part of JB02	
	JT822	EMV7122-004	CONNECT TERMINAL (4PIN) a part of JB02	
	RY501	ESK7D24-2120	RELAY	
	TB001	EMZ4001-001	TAB	
	TB002	EMZ4001-001	TAB	
	WR005	QWE881-24RR	VINYL WIRE	U
	WR006	QWE882-26RR	WIRE	U
	WR007	QWE883-22RR	WIRE	U
	WR008	QWE884-26RR	VINYL WIRE	U
	WR009	QWE886-24RR	WIRE	U
	WR010	QWE888-20RR	WIRE	U

△ : SAFETY PARTS

■ ENB-179 H Selector, System & Deck Controller PC Board Ass'y

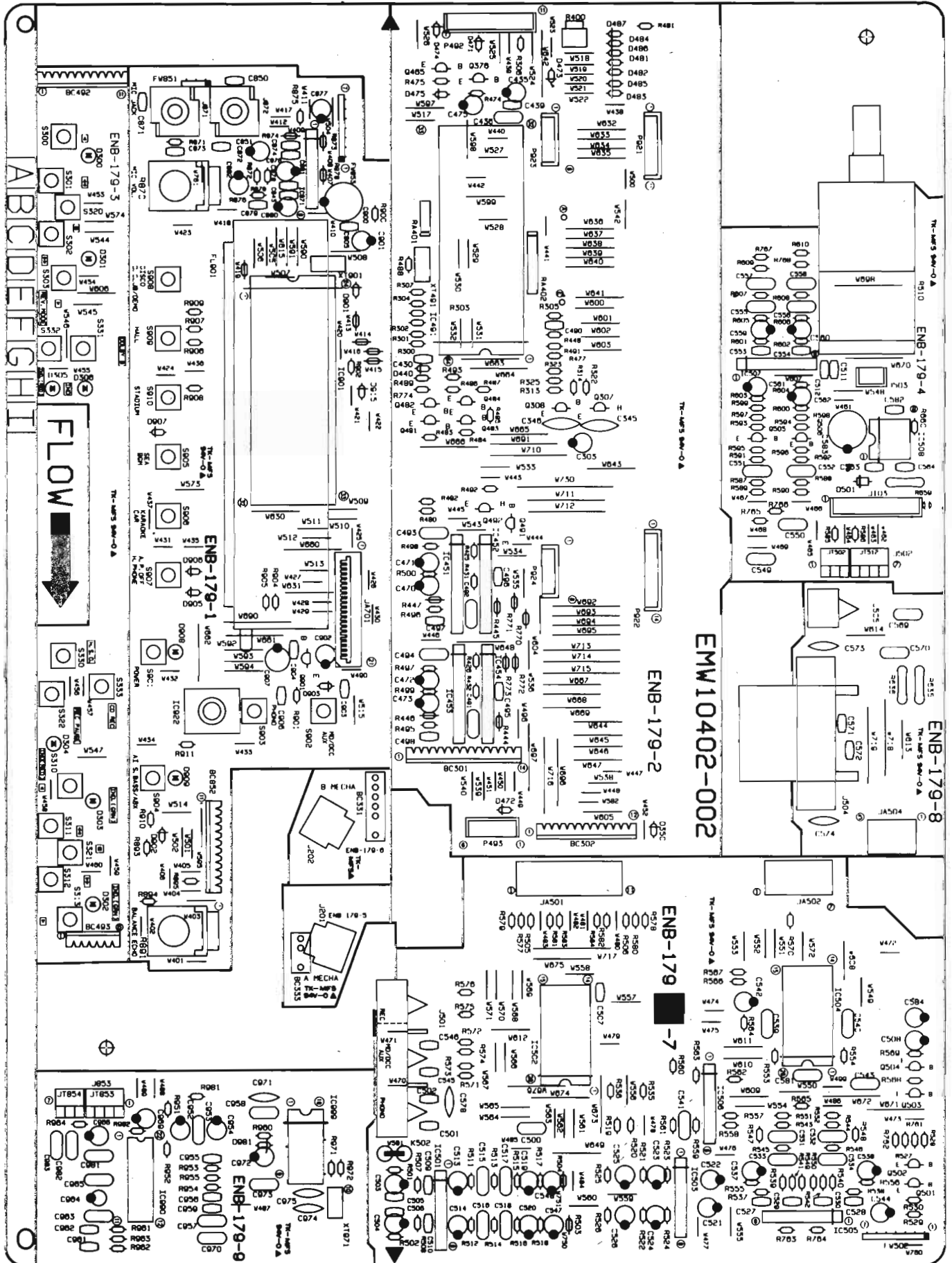

TRANSISTORS

Δ	ITEM	PART NUMBER	DESCRIPTION	AREA
	Q307	2SC1740S(R,S)	SI.TRANSISTROHM	
	Q308	2SC1740S(R,S)	SI.TRANSISTROHM	
	Q376	DTC144ES	DIGITAL TRAROHM	
	Q465	DTA114YS	DIGITAL TRAROHM	
	Q481	2SC1740S(R,S)	SI.TRANSISTROHM	
	Q482	2SC1740S(R,S)	SI.TRANSISTROHM	
	Q483	2SA933S(R,S)	SI.TRANSIST	
	Q484	2SA933S(R,S)	SI.TRANSIST	
	Q491	DTC144ES	DIGITAL TRAROHM	
	Q492	DTC144ES	DIGITAL TRAROHM	
	Q501	2SD2144S(VW)	SI.TRANSISTROHM	
	Q502	2SD2144S(VW)	SI.TRANSISTROHM	
	Q503	DTA144ES	DIGITAL TRAROHM	
	Q504	2SC1740S(R,S)	SI.TRANSISTROHM	
	Q505	2SK301(P,Q)	F.E.T. MATSUSHITA	
	Q506	2SK301(P,Q)	F.E.T. MATSUSHITA	
	Q901	DTC114YS	DIGITAL TRAROHM	

Δ : SAFETY PARTS

I. C. S.

Δ	ITEM	PART NUMBER	DESCRIPTION	AREA
	IC451	LB1641	I.C(DIGI-OTSANYO	
	IC452	LB1641	I.C(DIGI-OTSANYO	
	IC453	LB1641	I.C(DIGI-OTSANYO	
	IC454	LB1641	I.C(DIGI-OTSANYO	
	IC491	MD614081SD93	I.C(MICRO-CHITACHI	U
	IC501	VC4580LD	I.C(MONO-ANDAINICHI	
	IC502	TC9163N	I.C(DIGI-MOTOSHIBA	
	IC503	VC4580L	I.C(MONO-ANDAINICHI	
	IC504	TC9162N	I.C(DIGI-MOTOSHIBA	
	IC505	XRA15218N	I.C(MONO-AN	
	IC506	XRA15218N	I.C(MONO-AN	U
	IC507	VC4580L	I.C(MONO-ANDAINICHI	
	IC508	LB1639-CV	I.C(DIGI-OTSANYO	
	IC871	XRA15218N	I.C(MONO-AN	U
	IC901	MN171202JHX	I.C(MICRO-CMATSUSHITA	U
	IC922	NJH32H380A	I.C(M) DAINICHI	U
	IC990	BA7725S	I.C(M) ROHM	U
	IC999	BU9251S	I.C(M) ROHM	U

Δ : SAFETY PARTS

DIODES

Δ	ITEM	PART NUMBER	DESCRIPTION	AREA
	D300	SLR-342MCA47	L.E.D. ROHM	
	D301	SLR-342MCA47	L.E.D. ROHM	
	D302	SLR-342MCA47	L.E.D. ROHM	
	D303	SLR-342MCA47	L.E.D. ROHM	
	D304	SLR-342VC3F	L.E.D. ROHM	
	D305	SLR-342VC3F	L.E.D. ROHM	
	D306	SLR-342VC3F	L.E.D. ROHM	
	D350	1SS119	SI.DIODE	
	D440	1SS119	SI.DIODE	
	D471	1SS119	SI.DIODE	
	D472	1SS119	SI.DIODE	
	D473	1SS119	SI.DIODE	U
	D474	1SS119	SI.DIODE	
	D475	1SS119	SI.DIODE	
	D481	1SS119	SI.DIODE	
	D482	1SS119	SI.DIODE	U
	D483	1SS119	SI.DIODE	
	D484	1SS119	SI.DIODE	
	D485	1SS119	SI.DIODE	
	D487	1SS119	SI.DIODE	
	D501	1SR139-200	SI.DIODE ROHM	
	D901	1SS119	SI.DIODE	
	D902	1SS119	SI.DIODE	
	D903	1SS119	SI.DIODE	
	D905	1SS119	SI.DIODE	
	D906	1SS119	SI.DIODE	
	D907	1SS119	SI.DIODE	
	D908	SLR-342MCA47	L.E.D. ROHM	U
	D909	SLR-342VC3F	L.E.D. ROHM	
	D911	1SS119	SI.DIODE	U
	D912	1SS119	SI.DIODE	
	D915	1SS119	SI.DIODE	
	D981	MTZ5-1JC	ZENER DIODEROHM	U

Δ : SAFETY PARTS

CAPACITORS

Δ	ITEM	PART NUMBER	DESCRIPTION	AREA
	C303	QEK51HM-105G	1MF 50V AL E.CAPAC	IT
	C345	QCF21HP-223	0.022MF 50V CERAMIC	
	C346	QCF21HP-223	0.022MF 50V CERAMIC	
	C430	QCGB1HK-102	1000PF 50V CER.CAPACI	TO
	C435	QETB1CM-476	47MF 16V AL E.CAPAC	IT
	C436	QCZ0202-155	1.5MF 25V CER.RESIST	OR
	C439	QCVB1CM-103	0.01MF 16V CERAMIC	
	C471	QCVB1CM-103	0.01MF 16V CERAMIC	U
	C475	QETB1CM-476	47MF 16V AL E.CAPAC	IT
	C491	QFLB1HJ-223	0.022MF 50V MYLAR CAPA	CI
	C492	QFLB1HJ-223	0.022MF 50V MYLAR CAPA	CI
	C493	QFLB1HJ-223	0.022MF 50V MYLAR CAPA	CI
	C494	QFLB1HJ-223	0.022MF 50V MYLAR CAPA	CI
	C495	QCVB1CM-103	0.01MF 16V CERAMIC	
	C496	QCVB1CM-103	0.01MF 16V CERAMIC	
	C497	QCVB1CM-103	0.01MF 16V CERAMIC	
	C498	QCVB1CM-103	0.01MF 16V CERAMIC	
	C500	QFLB1HJ-103	0.01MF 50V MYLAR CAPA	CI
	C501	QCBB1HK-101	100PF 50V CERAMIC	U
	C502	QCBB1HK-101	100PF 50V CERAMIC	U
	C503	QETB1HM-475	4.7MF 50V AL E.CAPAC	IT
	C504	QETB1HM-475	4.7MF 50V AL E.CAPAC	IT
	C505	QCBB1HK-101	100PF 50V CERAMIC	
	C506	QCBB1HK-101	100PF 50V CERAMIC	
	C507	QCBB1HK-561Y	560PF 50V CER.CAPACI	TO
	C508	QETB1HM-475	4.7MF 50V AL E.CAPAC	IT
	C509	QCBB1HK-101	100PF 50V CERAMIC	
	C510	QCBB1HK-101	100PF 50V CERAMIC	
	C511	EEZ2505-476	47MF 50V AL E.CAPAC	IT U
	C512	QCHB1EZ-223	0.022MF 25V CER.CAPACI	TO U
	C513	QETB1EM-476	47MF 25V AL E.CAPAC	IT
	C514	QETB1EM-476	47MF 25V AL E.CAPAC	IT
	C515	QFLB1HJ-682	6800PF 50V MYLAR CAPA	CI
	C516	QFLB1HJ-682	6800PF 50V MYLAR CAPA	CI
	C517	QFLB1HJ-182	1800PF 50V MYLAR CAPA	CI
	C518	QFLB1HJ-182	1800PF 50V MYLAR CAPA	CI
	C519	QETB1CM-226	22MF 16V E.CAPACITO	R
	C520	QETB1CM-226	22MF 16V E.CAPACITO	R
	C521	EEZ2505-476	47MF 50V AL E.CAPAC	IT U
	C522	EEZ2505-476	47MF 50V AL E.CAPAC	IT U
	C523	EEZ2505-226	22MF 50V AL E.CAPAC	IT U
	C524	EEZ2505-226	22MF 50V AL E.CAPAC	IT U
	C525	EEZ2505-226	22MF 50V AL E.CAPAC	IT U
	C526	EEZ2505-226	22MF 50V AL E.CAPAC	IT U
	C527	QCSB1HJ-220	22PF 50V CER.CAPACI	TO
	C528	QCSB1HJ-220	22PF 50V CER.CAPACI	TO
	C529	QCSB1HJ-470	47PF 50V CER.RESIST	OR
	C530	QCSB1HJ-470	47PF 50V CER.RESIST	OR
	C531	QFV81HJ-124	0.12MF 50V THIN FILM	CA
	C532	QFV81HJ-124	0.12MF 50V THIN FILM	CA
	C533	QFV81HJ-124	0.12MF 50V THIN FILM	CA
	C534	QFV81HJ-124	0.12MF 50V THIN FILM	CA
	C537	QETB1HM-475	4.7MF 50V AL E.CAPAC	IT
	C538	QETB1HM-475	4.7MF 50V AL E.CAPAC	IT
	C539	QFV81HJ-103	0.01MF 50V THIN FILM	CA
	C540	QFV81HJ-103	0.01MF 50V THIN FILM	CA
	C541	QFLB1HJ-683	0.068MF 50V MYLAR CAPA	CI U
	C542	QETB1HM-475	4.7MF 50V AL E.CAPAC	IT U
	C543	QFV81HJ-563	0.056MF 50V THIN FILM	CA
	C544	QETB1EM-106	10MF 25V AL E.CAPAC	IT
	C547	QETB1CM-226	22MF 16V E.CAPACITO	R
	C548	QETB1CM-226	22MF 16V E.CAPACITO	R
	C549	QFLB1HJ-393	0.039MF 50V MYLAR CAPA	CI
	C550	QFLB1HJ-393	0.039MF 50V MYLAR CAPA	CI
	C551	QFLB1HJ-104	0.1MF 50V MYLAR CAPA	CI
	C552	QFLB1HJ-104	0.1MF 50V MYLAR CAPA	CI
	C553	QCSB1HJ-220	22PF 50V CER.CAPACI	TO
	C554	QCSB1HJ-220	22PF 50V CER.CAPACI	TO
	C555	QFLB1HJ-104	0.1MF 50V MYLAR CAPA	
	C556	QFLB1HJ-104	0.1MF 50V MYLAR CAPA	
	C557	QFLB1HJ-104	0.1MF 50V MYLAR CAPA	
	C558	QFLB1HJ-104	0.1MF 50V MYLAR CAPA	
	C559	QETB1CM-226	22MF 16V E.CAPACITO	R
	C560	QETB1CM-226	22MF 16V E.CAPACITO	R
	C561	QER51HM-225G	2.2MF 50V AL E.CAPAC	IT
	C562	QER51HM-225G	2.2MF 50V AL E.CAPAC	IT
	C563	QCHB1EZ-223	0.022MF 25V CER.CAPACI	TO
	C564	QCHB1EZ-223	0.022MF 25V CER.CAPACI	TO
	C578	QCF21HP-223	0.022MF 50V CERAMIC	U
	C581	QFLB1HJ-103	0.01MF 50V MYLAR CAPA	CI
	C582	QCVB1CM-103	0.01MF 16V CERAMIC	
	C583	QETBOJM-108	1000MF 6.3V AL E.CAPAC	IT U
	C584	QETB1HM-475	4.7MF 50V AL E.CAPAC	IT
	C843	QCSB1HJ-470	47PF 50V CER.RESIST	OR U
	C871	QCGB1HK-102	1000PF 50V CER.CAPACI	TO U
	C872	QETB1HM-105	1MF 50V AL E.CAPAC	IT U
	C873	QCGB1HK-102	1000PF 50V CER.CAPACI	TO U
	C876	QCBB1HK-101	100PF 50V CERAMIC	U
	C877	QETB1HM-475	4.7MF 50V AL E.CAPAC	IT U
	C878	QCBB1HK-101	100PF 50V CERAMIC	U
	C879	QCVB1CM-103	0.01MF 16V CERAMIC	U
	C880	QETB1CM-226	22MF 16V E.CAPACITO	R U
	C881	QETB1CM-226	22MF 16V E.CAPACITO	R U
	C882	QETB1HM-105	1MF 50V AL E.CAPAC	IT U
	C900	QETBOJM-108	1000MF 6.3V AL E.CAPAC	IT

Δ : SAFETY PARTS

CAPACITORS

Δ	ITEM	PART NUMBER	DESCRIPTION	AREA
	C901	QEK61AM-227ZN	220MF 10V ELECTRO	
	C902	QETB1HM-225	2.2MF 50V E.CAPACITO R	
	C903	QCVB1CM-103	0.01MF 16V CERAMIC	
	C904	QCVB1CM-103	0.01MF 16V CERAMIC	
	C905	QCHB1EZ-223	0.022MF 25V CER.CAPACI TO	
	C906	QCHB1EZ-223	0.022MF 25V CER.CAPACI TO	
	C907	QETB1AM-107N	100MF 10V ELECTRO	
	C911	QCBB1HK-221Y	220PF 50V CER.CAPACI TO U	
	C952	QETB1EM-226	22MF 25V E.CAPACITO R U	
	C953	QFV81HJ-104	0.1MF 50V THIN FILM CA U	
	C954	QETB1HM-474	0.47MF 50V ELECTRO U	
	C955	QCXB1CM-562	5600PF 16V CERAMIC U	
	C956	QCGB1HK-821	820PF 50V CER.CAPACI TO U	
	C957	QFLB1HJ-183	0.018MF 50V MYLAR CAPA CI U	
	C958	QFLB1HJ-104	0.1MF 50V MYLAR CAPA CI U	
	C959	QCVB1CM-103	0.01MF 16V CERAMIC U	
	C961	QCXB1CM-222	2200PF 16V CER.CAPACI TO U	
	C962	QCVB1CM-103	0.01MF 16V CERAMIC U	
	C963	QFLB1HJ-333	0.033MF 50V MYLAR CAPA CI U	
	C964	QEK61HM-474G	0.47MF 50V ELECTRO U	
	C965	QFV81HJ-104	0.1MF 50V THIN FILM CA U	
	C966	QETB1HM-105	1MF 50V AL E.CAPAC IT U	
	C969	QETB1CM-476	47MF 16V AL E.CAPAC IT U	
	C970	QFLB1HJ-104	0.1MF 50V MYLAR CAPA CI U	
	C971	QCS21HJ-221	220PF 50V CER.CAPACI TO U	
	C972	QETB1CM-107	100MF 16V AL E.CAPAC IT U	
	C973	QFLB1HJ-103	0.01MF 50V MYLAR CAPA CI U	
	C974	QCS21HJ-101	100PF 50V CERAMIC U	
	C975	QCS21HJ-101	100PF 50V CERAMIC U	
	C981	QFV81HJ-104	0.1MF 50V THIN FILM CA U	
	C982	QFV81HJ-104	0.1MF 50V THIN FILM CA U	
	C983	QFV81HJ-104	0.1MF 50V THIN FILM CA U	

Δ : SAFETY PARTS

RESISTORS

Δ	ITEM	PART NUMBER	DESCRIPTION	AREA
	R300	QRD161J-201	200 1/6W CARBON RES IS U	
	R301	QRD167J-271	270 1/6W CARBON RES IS U	
	R302	QRD161J-201	200 1/6W CARBON RES IS U	
	R303	QRD167J-221	220 1/6W CARBON RES IS U	
	R304	QRD167J-271	270 1/6W CARBON RES IS U	
	R305	QRD161J-201	200 1/6W CARBON RES IS U	
	R307	QRD167J-391	390 1/6W CARBON RES IS U	
	R313	QRD167J-103	10K 1/6W CARBON RES IS	
	R314	QRD161J-105	1M 1/6W CARBON RES IS	
	R322	QRD167J-913	91K 1/6W CARBON RES IS	
	R323	QRD161J-105	1M 1/6W CARBON RES IS	
	R325	QRD167J-104	100K 1/6W CARBON RES IS	
	R400	QVPA603-103A	10K TRIMMER RE SI	
	R425	QRD161J-432	4.3K 1/6W CARBON RES IS	
	R426	QRD161J-432	4.3K 1/6W CARBON RES IS	
	R431	QRD167J-103	10K 1/6W CARBON RES IS	
	R432	QRD167J-103	10K 1/6W CARBON RES IS	
	R435	QRD167J-222	2.2K 1/6W CARBON RES IS	
	R436	QRD167J-103	10K 1/6W CARBON RES IS	
	R449	QRD167J-222	2.2K 1/6W CARBON RES IS U	
	R450	QRD167J-222	2.2K 1/6W CARBON RES IS U	
	R474	QRD161J-274	270K 1/6W CARBON RES IS	
	R475	QRD167J-104	100K 1/6W CARBON RES IS	
	R477	QRD167J-472	4.7K 1/6W CARBON RES IS	
	R480	QRD167J-132	1.3K 1/6W CARBON RES IS	
	R481	QRD167J-133	13K 1/6W CARBON RES IS	
	R482	QRD167J-243	24K 1/6W CARBON RES IS	
	R483	QRD161J-184	180K 1/6W CARBON RES IS	
	R484	QRD167J-224	220K 1/6W CARBON RES IS U	
	R485	QRD167J-683	68K 1/6W CARBON RES IS	
	R486	QRD167J-224	220K 1/6W CARBON RES IS	
	R487	QRD167J-224	220K 1/6W CARBON RES IS	
	R488	QRD161J-105	1M 1/6W CARBON RES IS	
	R489	QRD167J-103	10K 1/6W CARBON RES IS	
	R491	QRD167J-221	220 1/6W CARBON RES IS	
	R492	QRD167J-103	10K 1/6W CARBON RES IS	
	R493	QRD167J-103	10K 1/6W CARBON RES IS	
	R495	QRD167J-913	91K 1/6W CARBON RES IS	
	R496	QRD167J-913	91K 1/6W CARBON RES IS	
	R497	QRD167J-822	8.2K 1/6W CARBON RES IS	
	R498	QRD167J-822	8.2K 1/6W CARBON RES IS	
	R499	QRD161J-163	16K 1/6W CARBON RES IS	
	R500	QRD161J-163	16K 1/6W CARBON RES IS	
	R501	QRD167J-222	2.2K 1/6W CARBON RES IS	
	R502	QRD167J-222	2.2K 1/6W CARBON RES IS	
	R507	QRD167J-473	47K 1/6W CARBON RES IS	
	R508	QRD167J-473	47K 1/6W CARBON RES IS	
	R510	QVDB94B-E15C	100K VARIABLE R ES U	
	R511	QRD167J-471	470 1/6W CARBON RES IS U	
	R512	QRD167J-471	470 1/6W CARBON RES IS U	

Δ : SAFETY PARTS

RESISTORS

Δ	ITEM	PART NUMBER	DESCRIPTION	AREA
	R513	QRD167J-474	470K 1/6W CARBON RES IS	
	R514	QRD167J-474	470K 1/6W CARBON RES IS	
	R515	QRD167J-393	39K 1/6W CARBON RES IS	
	R516	QRD167J-393	39K 1/6W CARBON RES IS	
	R517	QRD167J-104	100K 1/6W CARBON RES IS	
	R518	QRD167J-104	100K 1/6W CARBON RES IS	
	R519	QRD161J-821	820 1/6W CARBON RES IS	
	R520	QRD161J-821	820 1/6W CARBON RES IS	
	R521	QRD167J-474	470K 1/6W CARBON RES IS U	
	R522	QRD167J-474	470K 1/6W CARBON RES IS U	
	R523	QRD167J-104	100K 1/6W CARBON RES IS	
	R524	QRD167J-104	100K 1/6W CARBON RES IS	
	R525	QRD167J-104	100K 1/6W CARBON RES IS	
	R526	QRD167J-104	100K 1/6W CARBON RES IS	
	R527	QRD167J-103	10K 1/6W CARBON RES IS	
	R528	QRD167J-103	10K 1/6W CARBON RES IS	
	R529	QRD167J-102	1K 1/6W CARBON RES IS U	
	R530	QRD167J-102	1K 1/6W CARBON RES IS U	
	R535	QRD161J-821	820 1/6W CARBON RES IS	
	R536	QRD161J-821	820 1/6W CARBON RES IS	
	R537	QRD167J-103	10K 1/6W CARBON RES IS	
	R538	QRD167J-103	10K 1/6W CARBON RES IS	
	R539	QRD167J-472	4.7K 1/6W CARBON RES IS	
	R540	QRD167J-472	4.7K 1/6W CARBON RES IS	
	R541	QRD167J-472	4.7K 1/6W CARBON RES IS	
	R542	QRD167J-472	4.7K 1/6W CARBON RES IS	
	R543	QRD161J-101	100 1/6W CARBON RES IS	
	R544	QRD161J-101	100 1/6W CARBON RES IS	
	R545	QRD167J-472	4.7K 1/6W CARBON RES IS	
	R546	QRD167J-472	4.7K 1/6W CARBON RES IS	
	R547	QRD167J-563	56K 1/6W CARBON RES IS U	
	R548	QRD167J-563	56K 1/6W CARBON RES IS U	
	R549	QRD167J-302	3K 1/6W CARBON U	
	R550	QRD167J-302	3K 1/6W CARBON U	
	R551	QRD161J-432	4.3K 1/6W CARBON RES IS U	
	R552	QRD161J-432	4.3K 1/6W CARBON RES IS U	
	R553	QRD161J-183	18K 1/6W CARBON RES IS U	
	R554	QRD161J-183	18K 1/6W CARBON RES IS U	
	R555	QRD167J-104	100K 1/6W CARBON RES IS U	
	R556	QRD167J-104	100K 1/6W CARBON RES IS U	
	R557	QRD167J-473	47K 1/6W CARBON RES IS U	
	R558	QRD167J-473	47K 1/6W CARBON RES IS U	
	R559	QRD167J-473	47K 1/6W CARBON RES IS U	
	R560	QRD167J-473	47K 1/6W CARBON RES IS U	
	R561	QRD167J-473	47K 1/6W CARBON RES IS U	
	R562	QRD167J-473	47K 1/6W CARBON RES IS U	
	R563	QRD167J-473	47K 1/6W CARBON RES IS U	
	R564	QRD167J-104	100K 1/6W CARBON RES IS U	
	R565	QRD167J-332	3.3K 1/6W CARBON RES IS	
	R566	QRD167J-104	100K 1/6W CARBON RES IS U	
	R567	QRD167J-472	4.7K 1/6W CARBON RES IS	
	R568	QRD167J-102	1K 1/6W CARBON RES IS	
	R569	QRD161J-105	1M 1/6W CARBON RES IS	
	R570	QRD167J-102	1K 1/6W CARBON RES IS	
	R571	QRD167J-102	1K 1/6W CARBON RES IS U	
	R572	QRD167J-102	1K 1/6W CARBON RES IS U	
	R573	QRD167J-104	100K 1/6W CARBON RES IS U	
	R574	QRD167J-104	100K 1/6W CARBON RES IS U	
	R575	QRD167J-222	2.2K 1/6W CARBON RES IS	
	R576	QRD167J-222	2.2K 1/6W CARBON RES IS	
	R577	QRD167J-221	220 1/6W CARBON RES IS U	
	R578	QRD167J-221	220 1/6W CARBON RES IS U	
	R579	QRD167J-104	100K 1/6W CARBON RES IS U	
	R580	QRD167J-104	100K 1/6W CARBON RES IS U	
	R581	QRD167J-221	220 1/6W CARBON RES IS U	
	R582	QRD167J-221	220 1/6W CARBON RES IS U	
	R583	QRD167J-104	100K 1/6W CARBON RES IS U	
	R584	QRD167J-104	100K 1/6W CARBON RES IS U	
	R585	QRD167J-332	3.3K 1/6W CARBON RES IS	
	R586	QRD167J-332	3.3K 1/6W CARBON RES IS	
	R587	QRD167J-103	10K 1/6W CARBON RES IS	
	R588	QRD167J-103	10K 1/6W CARBON RES IS	
	R589	QRD167J-473	47K 1/6W CARBON RES IS	
	R590	QRD167J-473	47K 1/6W CARBON RES IS	
	R591	QRD161J-561	560 1/6W CARBON RES IS U	
	R592	QRD161J-561	560 1/6W CARBON RES IS U	
	R593	QRD167J-682	6.8K 1/6W CARBON RES IS U	
	R594	QRD167J-682	6.8K 1/6W CARBON RES IS U	
	R595	QRD167J-473	47K 1/6W CARBON RES IS	
	R596	QRD167J-473	47K 1/6W CARBON RES IS	
	R597	QRD161J-561	560 1/6W CARBON RES IS U	
	R598	QRD161J-561	560 1/6W CARBON RES IS U	
	R599	QRD161J-432	4.3K 1/6W CARBON RES IS	
	R600	QRD161J-432	4.3K 1/6W CARBON RES IS	
	R601	QRD167J-473	47K 1/6W CARBON RES IS	
	R602	QRD167J-473	47K 1/6W CARBON RES IS	
	R603	QRD167J-473	47K 1/6W CARBON RES IS	
	R604	QRD167J-473	47K 1/6W CARBON RES IS	
	R605	QRD167J-103	10K 1/6W CARBON RES IS U	
	R606	QRD167J-103	10K 1/6W CARBON RES IS U	
	R607	QRD167J-103	10K 1/6W CARBON RES IS U	
	R608	QRD167J-103	10K 1/6W CARBON RES IS U	
	R609	QRD167J-103	10K 1/6W CARBON RES IS U	
	R610	QRD167J-103	10K 1/6W CARBON RES IS U	
Δ	R659	QRD14CJ-4R7S	4.7 1/4W UNF.CARBON R U	

Δ : SAFETY PARTS

RESISTORS

Δ	ITEM	PART NUMBER	DESCRIPTION	AREA
	R660	QRD167J-221	220 1/6W CARBON RES	IS
	R761	QRD167J-224	220K 1/6W CARBON RES	IS
	R762	QRD167J-224	220K 1/6W CARBON RES	IS
	R763	QRD167J-103	10K 1/6W CARBON RES	IS
	R764	QRD167J-103	10K 1/6W CARBON RES	IS
	R765	QRD167J-224	220K 1/6W CARBON RES	IS U
	R766	QRD167J-224	220K 1/6W CARBON RES	IS U
	R767	QRD167J-334	330K 1/6W CARBON RES	IS U
	R768	QRD167J-334	330K 1/6W CARBON RES	IS U
	R774	QRD167J-221	220 1/6W CARBON RES	IS
	R870	QVGAB1B-E54D	50K VARIABLE RES	ES U
	R871	QRD167J-102	1K 1/6W CARBON RES	IS U
	R872	QRD167J-103	10K 1/6W CARBON RES	IS U
	R876	QRD167J-912	9.1K 1/6W CARBON	U
	R878	QRD167J-104	100K 1/6W CARBON RES	IS U
	R879	QRD161J-203	20K 1/6W CARBON RES	IS U
	R891	QVGAB1B-E54C	50K VARIABLE RES	U
	R893	QRD167J-133	13K 1/6W CARBON RES	IS U
	R894	QRD167J-104	100K 1/6W CARBON RES	IS U
	R895	QRD167J-104	100K 1/6W CARBON RES	IS U
	R900	QRD161J-101	100 1/6W CARBON RES	IS
	R901	QRD167J-104	100K 1/6W CARBON RES	IS
	R902	QRD167J-103	10K 1/6W CARBON RES	IS
	R904	QRD167J-473	47K 1/6W CARBON RES	IS
	R905	QRD167J-104	100K 1/6W CARBON RES	IS
	R906	QRD167J-473	47K 1/6W CARBON RES	IS
	R907	QRD167J-473	47K 1/6W CARBON RES	IS
	R908	QRD167J-473	47K 1/6W CARBON RES	IS
	R909	QRD167J-473	47K 1/6W CARBON RES	IS
	R910	QRD167J-221	220 1/6W CARBON RES	IS
	R911	QRD167J-270	27 1/6W CARBON	IS
	R951	QRD167J-152	1.5K 1/6W CARBON RES	IS U
	R952	QRD167J-123	12K 1/6W CARBON RES	IS U
	R953	QRD167J-103	10K 1/6W CARBON RES	IS U
	R954	QRD167J-103	10K 1/6W CARBON RES	IS U
	R955	QRD167J-103	10K 1/6W CARBON RES	IS U
	R960	QRD167J-472	4.7K 1/6W CARBON RES	IS U
	R961	QRD167J-103	10K 1/6W CARBON RES	IS U
	R962	QRD167J-103	10K 1/6W CARBON RES	IS U
	R963	QRD167J-103	10K 1/6W CARBON RES	IS U
	R964	QRD167J-471	470 1/6W CARBON RES	IS U
	R971	QRD161J-105	1M 1/6W CARBON RES	IS U
	R972	QRD167J-682	6.8K 1/6W CARBON RES	IS U
	R981	QRD161J-331	330 1/6W CARBON RES	IS U
	R982	QRD167J-223	22K 1/6W CARBON RES	IS U
	RA401	QRB049J-103	10K 1/10W RESISTOR	SI
	RA402	QRB089J-103	10K 1/10W NETWORK RE	SI
	RA403	QRB069J-222	2.2K 1/10W NETWORK RE	SI
	RA404	QRB129J-222	2.2K 1/10W RESISTOR A	RR
	RA405	QRB049J-104	100K 1/10W RESISTOR A	RR
	RA901	QRB109J-104	100K 1/10W NETWORK RE	SI
	RA902	QRB169J-104	100K 1/10W RESISTOR A	RR

Δ :SAFETY PARTS

OTHERS

Δ	ITEM	PART NUMBER	DESCRIPTION	AREA
	J103	QWE350-08RR	WIRE	U
	J201	EMV5109-011A	MALE CONNECTOR(11PIN) Main Volume CB	
	J202	EMV7155-106R	CONNECT TERMINAL	
	J501	EMN00TV-604A	PIN JACK(Input Terminal)	U
	J503	EMV5109-003A	MALE CONNECTOR(3PIN) Main Volume CB	
	J504	EMB90TV-404A	SPEAKER TERMINAL	U
	J871	QMS3R20-E40S	HEADPHONE JACK	U
	J872	QMS3R20-E40S	HEADPHONE JACK	U
	P492	EMV5142-911	CONNECT TERMINAL(11PIN) from Deck Operation CB	
	P493	EMV5109-006A	CONNECT TERMINAL(6PIN) from Deck Operation CB	
	P921	VMC0234-P11	CONNECT TERMINAL(11PIN) A Mecha.: Cam / Reel Switch	
	P922	VMC0234-P14	CONNECT TERMINAL(14PIN) B Mecha.: Cam / Reel Switch	
	P923	VMC0234-P08	CONNECT TERMINAL(8PIN) A Mecha.: Reel / Cam Motor	
	P924	VMC0234-P08	CONNECT TERMINAL(8PIN) B Mecha.: Reel / Cam Motor	
	S300	ESP0001-023M	TACT SWITCH(A REVERSE)	
	S301	ESP0001-023M	TACT SWITCH(A REWIND)	
	S302	ESP0001-023M	TACT SWITCH(AFF)	
	S303	ESP0001-023M	TACT SWITCH(A PLAY)	
	S310	ESP0001-023M	TACT SWITCH(B REVERSE)	
	S311	ESP0001-023M	TACT SWITCH(B REWIND)	
	S312	ESP0001-023M	TACT SWITCH(BFF)	
	S313	ESP0001-023M	TACT SWITCH(B PLAY)	
	S320	ESP0001-023M	TACT SWITCH(A STOP)	
	S321	ESP0001-023M	TACT SWITCH(B STOP)	
	S322	ESP0001-023M	TACT SWITCH(B REC PAUSE)	
	S330	ESP0001-023M	TACT SWITCH(A DD-B)	
	S331	ESP0001-023M	TACT SWITCH(DOLBY)	
	S332	ESP0001-023M	TACT SWITCH(REV. MODE)	
	S333	ESP0001-023M	TACT SWITCH(CD REC)	

Δ :SAFETY PARTS

OTHERS

Δ	ITEM	PART NUMBER	DESCRIPTION	AREA
	S901	ESP0001-023M	TACT SWITCH(POWER)	
	S902	ESP0001-023M	TACT SWITCH(MD/DCC)	
	S903	ESP0001-023M	TACT SWITCH(PHONO)	
	S904	ESP0001-023M	TACT SWITCH(AIS.BASS)	
	S905	ESP0001-023M	TACT SWITCH(SEA MODE)	
	S906	ESP0001-023M	TACT SWITCH(KARAOKE)	
	S907	ESP0001-023M	TACT SWITCH(A.P.OFF)	
	S908	ESP0001-023M	TACT SWITCH(DISCO)	
	S909	ESP0001-023M	TACT SWITCH(HALL)	
	S910	ESP0001-023M	TACT SWITCH(STADIUM)	
	BC301	EWS32E-A912	SOCKET WIRE ASSY(14PIN) to Deck CB	
	BC302	EWS32C-A912	SOCKET WIRE ASSY(12PIN) to Deck CB	
	BC331	EWS247-012J	SOCKET WIRE ASSY(7PIN) B Deck : Relay CB	
	BC333	EWS243-065J	SOCKET WIRE ASSY(4PIN) A Deck : Relay CB	
	BC492	EWS32B-A916	SOCKET WIRE ASSY(11PIN) Deck Operation CB	
	BC493	EWS266-F216	SOCKET WIRE ASSY(6PIN) Deck Operation CB	
	BC852	EWS26B-F213	SOCKET WIRE(11PIN) Mic / Balance	U
	BK901	E308331-001SMJ	FL HOLDER	U
	FL901	ELU0001-167	FUORESCENT DISPLAY TUBE	U
	FS435	E3400-431	FELT SPACER	
	FS436	E3400-431	FELT SPACER	
	FS484	E3400-431	FELT SPACER	
	FS901	E306805-014	FELT SPACER	
	FW502	EWR37B-13LST	FLAT WIRE ASSY(7PIN) to Main Volume CB	
	FW851	EWR33B-30LST	FLAT WIRE ASSY(3PIN) Headphone	
	FW853	EWR37B-25LST	FLAT WIRE ASSY(7PIN) to Ecor CB	U
	JA501	EMV7125-011R	MALE CONNECTOR(11PIN) Input / Select CB	
	JA502	EMV7125-007R	CONNECT TERMINAL(7PIN) Input / Select CB	
	JA504	EMV7125-005R	CONNECT TERMINAL(5PIN) Speaker CB	
	JA701	EMV7123-021	CONNECT TERMINAL(21PIN) Front CB	
	JT502	EMV7122-103	CONNECT TERMINAL(3PIN) a part of J502	
	JT512	EMV7122-004	CONNECT TERMINAL(4PIN) a part of J502	
	JT853	EMV7122-004	CONNECT TERMINAL(4PIN) Ecor CB	U
	JT854	EMV7122-103	CONNECT TERMINAL(3PIN) Ecor CB	U
	XT491	ECX0004-194KM	CERAMIC RESONATOR	
	XT901	ECX0060-000EM	CERAMIC RESONATOR	
	XT971	ECX0000-400KS	CERAMIC RESONATOR	U

Δ :SAFETY PARTS

General Exploded View and Parts List

Parts List

Symbol No.

M	3	M	M
---	---	---	---

Item	Part Number	Part Name	Q'ty	Description	Area
1	EFP-XTM30BKU(S)	FRONT PANEL ASS	1		
1-1	E102811-002ST	FRONT PANEL	1		
1-2	E308822-001	WINDOW SCREEN	1		
1-3	E406971-221	JVC MARK	1		
2	E75896-001	SPACER	2		
3	E69897-002	RUBBER CUSHION	2		
4	E208068-002	BACK PANEL	1		
5	E308844-002	DOOR HINGE	1		
6	E407966-001	SPRING	1		
7	SSSF2606M	TAPPING SCREW	3		
8	SDSF2608Z	SCREW	16		
9	EWPZ02-005	FLAT WIRE ASSY	1	F202	
10	E308826-001	PUSH BUTTON	1		
11	E407969-001	INDICATOR	1		
12	E102813-006SA	SUB PANEL ASSY	1		
12-1	E102813-006	SUB PANEL	1		
12-2	E308824-003	WINDOW SCREEN	1		
12-3	E406971-221	JVC MARK	1		
13	E308920-001	CABLE HOLDER	1		
14	E208071-001	PUSH BUTTON	1		
15	E208074-001	PUSH BUTTON	1		
16	EWR129K-27TT	FLAT WIRE	1	FC201	
17	E308821-001	STAY BRACKET	1		
18	E208070-001	CD FITTING	1		
19	SDSG3006M	SCREW	2		
20	E208067-001	REAR COVER	1		
21	SBSG3008CC	TAPPING SCREW	18		
22	E102810-001	CHASSIS BASE	1		
23	E75896-006	FELT SPACER	2		
24	GBSG3008Z	TAPPING SCREW	2		
25	-----	CHANGER MECHA ASSY	1	SEE PAGE 93	
26	E208065-012	REAR PANEL	1		
27	EWP902-042	FLAT WIRE ASSY	1		
28	E208069-006	METAL COVER	1		
29	E308833-001	MECHA BASE	1		
30	RF-500TB-12560	DC MOTOR	1		
31	VKR4207-203	MOTOR PULLEY	1		
32	E408037-001	ACTUATOR	1		
33	SDST2605Z	SCREW	2		
34	SPSK2625Z	SCREW	2		
35	E308829-001	DRIVE GEAR	1		
36	WDL316035	WASHER	1		
37	VKR4677-202	IDLER GEAR	1		
38	WDL214035	WASHER	1		
39	E407150-221	REEL BELT	1		
40	E407982-001	SPRING	1		
41	E308830-001	ACTION LEVER	1		
42	E407981-001	SPRING	1		
43	E308832-001	ACTION LEVER	1		
44	REE3000X	'E' WASHER	1		
45	ENC-111A	P.C BOARD ASSY	1		
45-1	QSP2K11-E04	PUSH SWITCH	2		
46	E406507-001	CAUTION LABEL	1		
-	E61029-005	NUMBER LABEL	1		
-	E70891-001	CLASS 1 LABEL	1		

● General Exploded View

Symbol No.

M	3	M	M
---	---	---	---

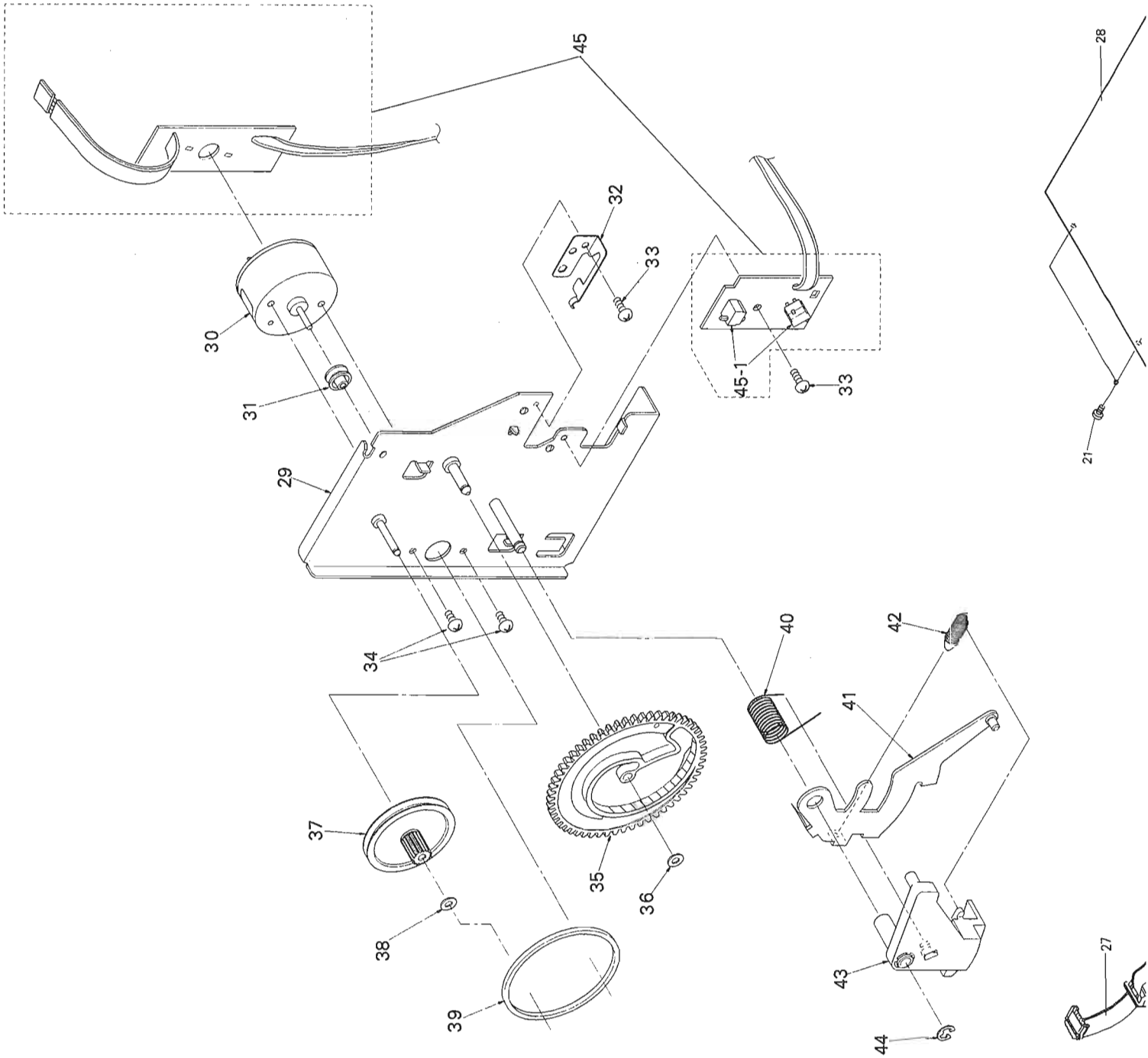

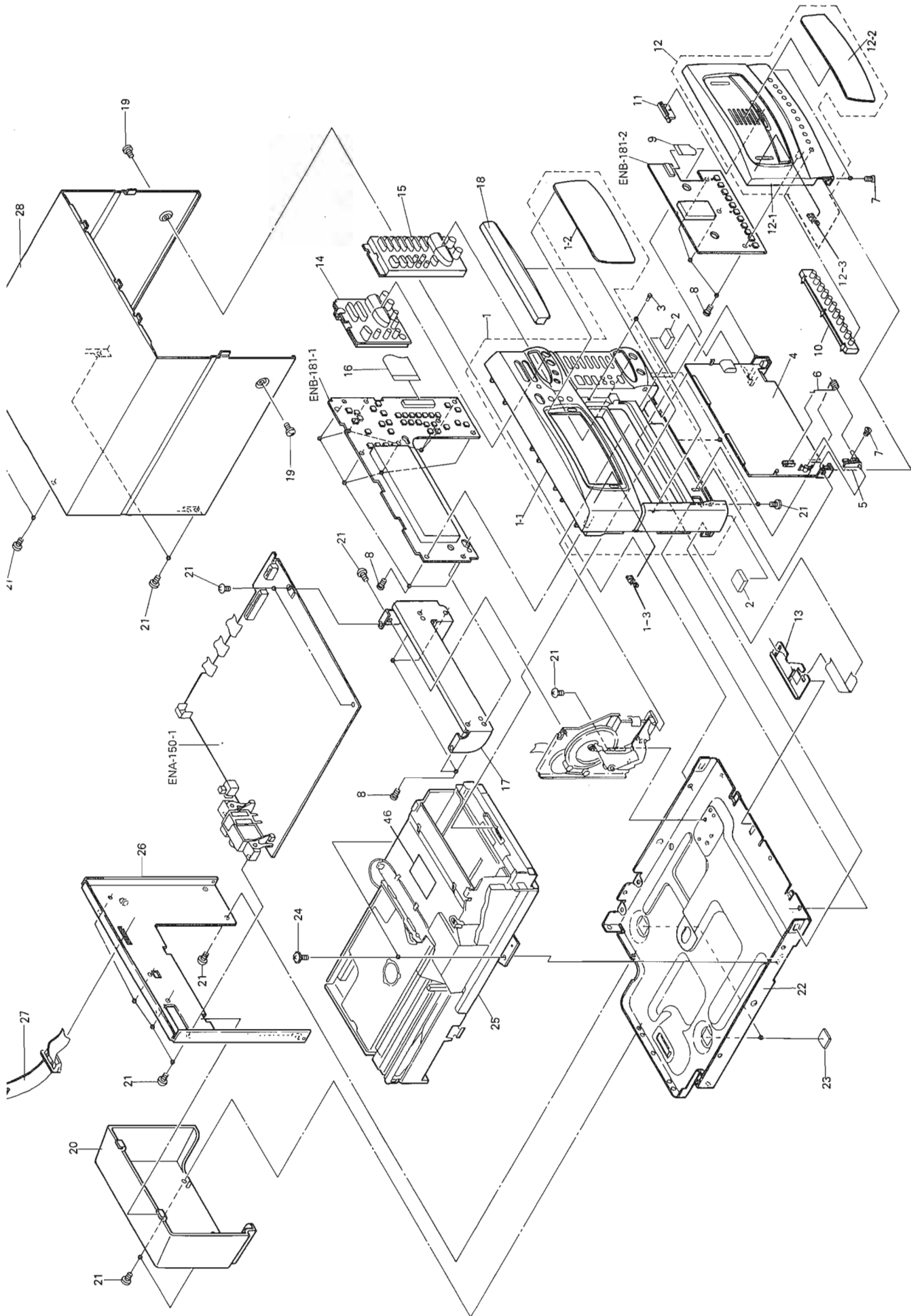

CD Changer Mechanism Ass'y and Parts List

Symbol No.

M	4	M	M
---	---	---	---

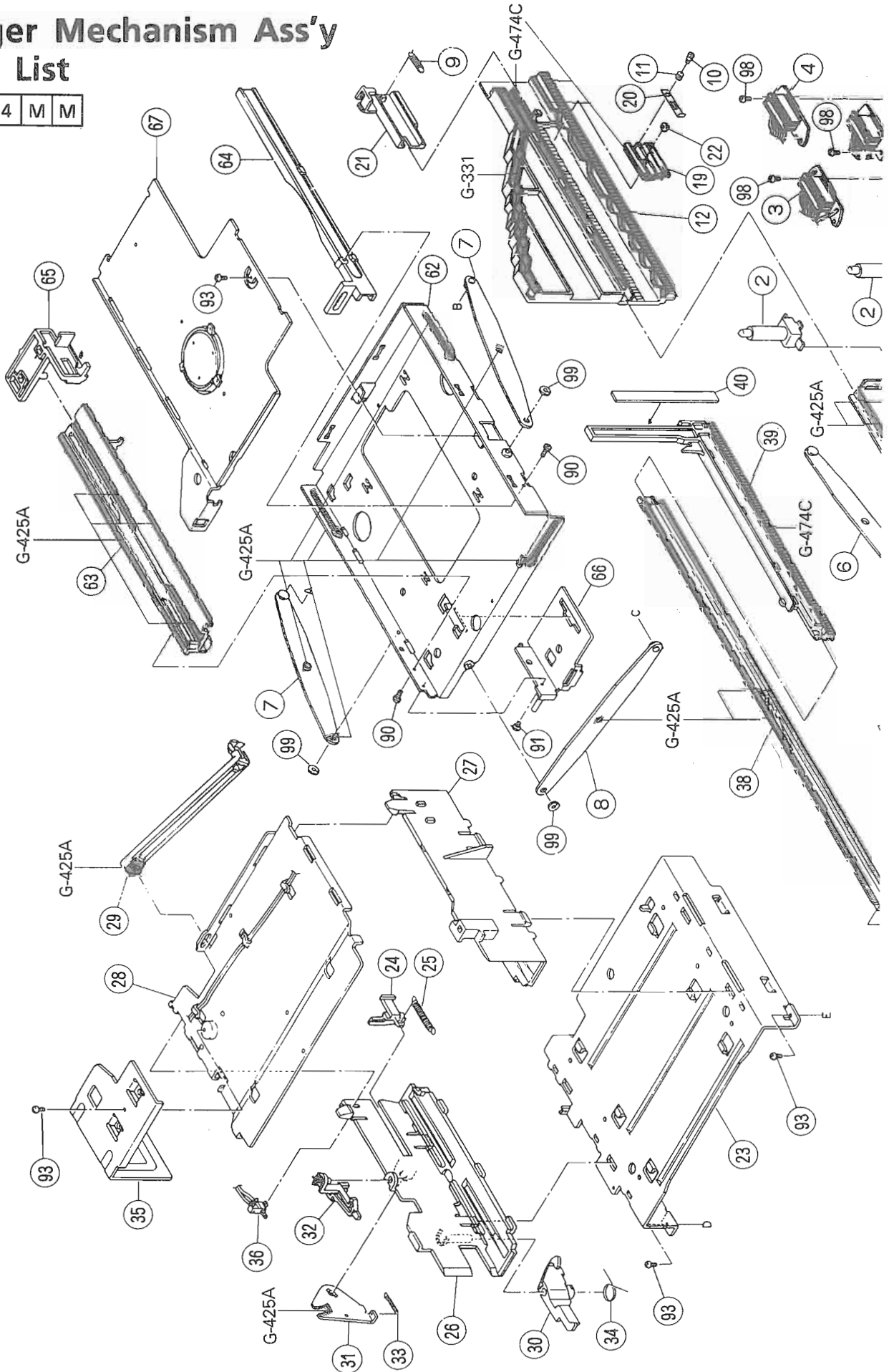

Grease G-425A : EBS0006-018B
 G-474C : EBS0006-019B

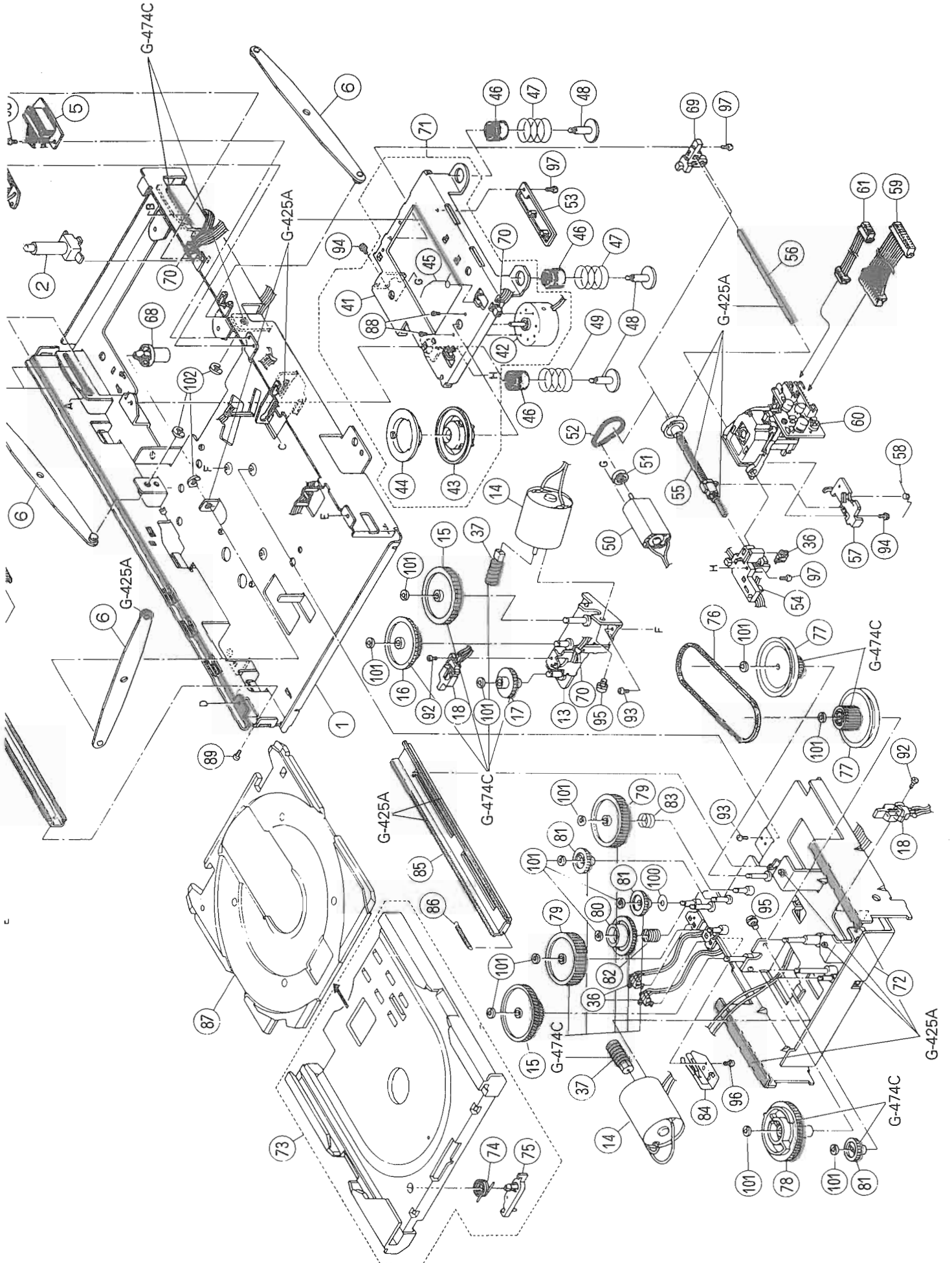

Symbol No.

M	4	M	M
---	---	---	---

■ Parts List (Changer Mechanism Ass'y)

△	Item	Part Number	Part Name	Q'ty	Description	Area
	1	30100101T	CHASSIS BASE	1		
	2	30050115T	GUIDE BOSS	2		
	3	300501302T	CONNECTOR PC BOARD A ASSY	1		
	4	301001301T	CONNECTOR PC BOARD D ASSY	1		
	5	300501304T	CONNECTOR PC BOARD P ASSY	1		
	6	301002502T	ELEVATOR ARM A ASSY	3		
	7	301002503T	ELEVATOR SIDE ARM B ASSY	2		
	8	301002504T	ELEVATOR FRONT ARM A ASSY	1		
	9	30100221T	CAM LEVER SPRING	1		
	10	30100222T	COLLAR SCREW	1		
	11	30100223T	CAM SPRING	1		
	12	30100202T	LIFT CAM	1		
	13	301002501T	ELEVATOR MOTOR BRACKET ASSY	1		
	14	RF-370C-15370	LOADING MOTOR	2		
	15	30100210T	ELEVATOR GEAR B	2		
	16	30100211T	ELEVATOR GEAR C	1		
	17	30100212T	ELEVATOR GEAR D	1		
	18	640101167T	LEAF SWITCH	1		
	19	30100204T	CAM SLIDER	1		
	20	30100205T	CAM SPRING PLATE	1		
	21	30100206T	CAM LEVER	1		
	22	30100207T	CAM ROLLER	1		
	23	30100301T	GUIDE BASE	1		
	24	30100311T	ELEVATOR SLIDE LEVER	1		
	25	30100312T	ELEVATOR SLIDE LEVER SPRING	1		
	26	301003703T	MAGAZINE GUIDE	1	LEFT	
	27	30050303T	MAGAZINE GUIDE	1	RIGHT	
	28	30100305T	GUIDE COVER	1		
	29	30100309T	TRAY STOPPER	1		
	30	30100310T	OPEN LEVER	1		
	31	30100308T	ELEVATOR KICK LEVER	1		
	32	30100307T	LOCK LEVER	1		
	33	30100309T	ELEVATOR KICK LEVER SPRING	1		
	34	30100313T	OPEN LEVER SPRING	1		
	35	301003706T	CAM STABILIZER	1		
	36	64020403T	PUSH SWITCH	4		
	37	30050508T	FEED GEAR A	2		
	38	301005501T	FEED RAIL ASSY	1		
	39	30100504T	HOOK SLIDE GEAR	1		
	40	30100505T	SLIDE GEAR PLATE	1		
	41	30050738T	TURN TABLE BASE	1		
	42	60020705T	SPINDLE MOTOR	1		
	43	30050729T	TURN TABLE PLATE	1		
	44	30050713T	CONTROLLER SPRING	1		
	45	30050742T	FLOATING RUBBER	1		
	46	30050721T	FLOATING SPRING (B)	3		
	47	30050715T	FLOATING SCREW	2		
	48	30050743T	FLOATING SPRING	3		
	49	30050740T	FEED MOTOR	1		
	50	60021102T	MOTOR PULLEY	1		
	51	30050709T	FEED MOTOR BELT	1		
	52	30050714T	PICK UP SUPPORT	1		
	53	30050737T	SHAFT HOLDER A	1		
	54	30050724T	FEED SCREW ASSY	1		
	55	300507303T	PICK UP SHAFT	1		

△	Item	Part Number	Part Name	Q'ty	Description	Area
	56	30050728T	FEED NUT SUPPORT	1		
	57	30050735T	FEED NUT SPRING	1		
	58	30050739T	WIRE	1		
	59	EWS26A-B428	PICK UP	1		
	60	OPTIMA-5S	WIRE	1		
	61	EWS264-B434	RAIL BASE ASSY	1	4PIN	
	62	301008503T	RAIL	1		
	63	30100802T	RAIL	1	LEFT	
	64	30100803T	HOOK LEVER	1	RIGHT	
	65	30100804T	LP BRACKET ASSY	1		
	66	301008502T	MAGAZINE HOLDER ASSY	1		
	67	301008301T	CHASSIS SUPPORT	1		
	68	30050114T	SHAFT HOLDER B	1		
	69	30050725T	TIE BAN	1		
	70	12030105T	TURN TABLE BASE ASSY	4		
	71	300507305	PLUS BASE ASSY	1		
	72	301004502T	PLUS RAIL BASE ASSY	1		
	73	301004301T	STOPPER SPRING	1		
	74	30100415T	STOPPER	1		
	75	30050416T	PLUS BELT	1		
	76	30100411T	PLUS GEAR A	1		
	77	30100403T	PLUS GEAR B	2		
	78	30100404T	FEED GEAR C	1		
	79	30100515T	FEED GEAR D	2		
	80	30100506T	FEED GEAR E	1		
	81	30100516T	FEED GEAR D SPRING	3		
	82	30100413T	FEED GEAR E SPRING	1		
	83	30100412T	SWITCH ACTUATOR	1		
	84	30100414T	PLUS SLIDE RAIL	1		
	85	30100409T	PLUS SLIDE RAIL SPRING	1		
	86	30100410T	PLUS 1 TRAY	1		
	87	E26554-004	SCREW	1		
	88	SPSK1722M	SCREW	2		
	89	9C0420253T	SCREW	1		
	90	9C0820601T	SCREW	2		
	91	9C1220301T	SCREW	1		
	92	9C0420403T	SCREW	2		
	93	9P0420031T	SCREW	6		
	94	9P0220031T	SCREW	2		
	95	9P0230041T	SCREW	2		
	96	9P1120032T	SCREW	1		
	97	9P0420051T	SCREW	3		
	98	9P0420041T	SCREW	3		
	99	9W0640040T	WASHER	3		
	100	9W0113080T	WASHER	2		
	101	9W0250110T	WASHER	14		
	102	REE3000X	E.RING	3		

Printed Circuit Board Ass'y and Parts List

■ ENA-150 □ CD,Tuner PC Board Ass'y

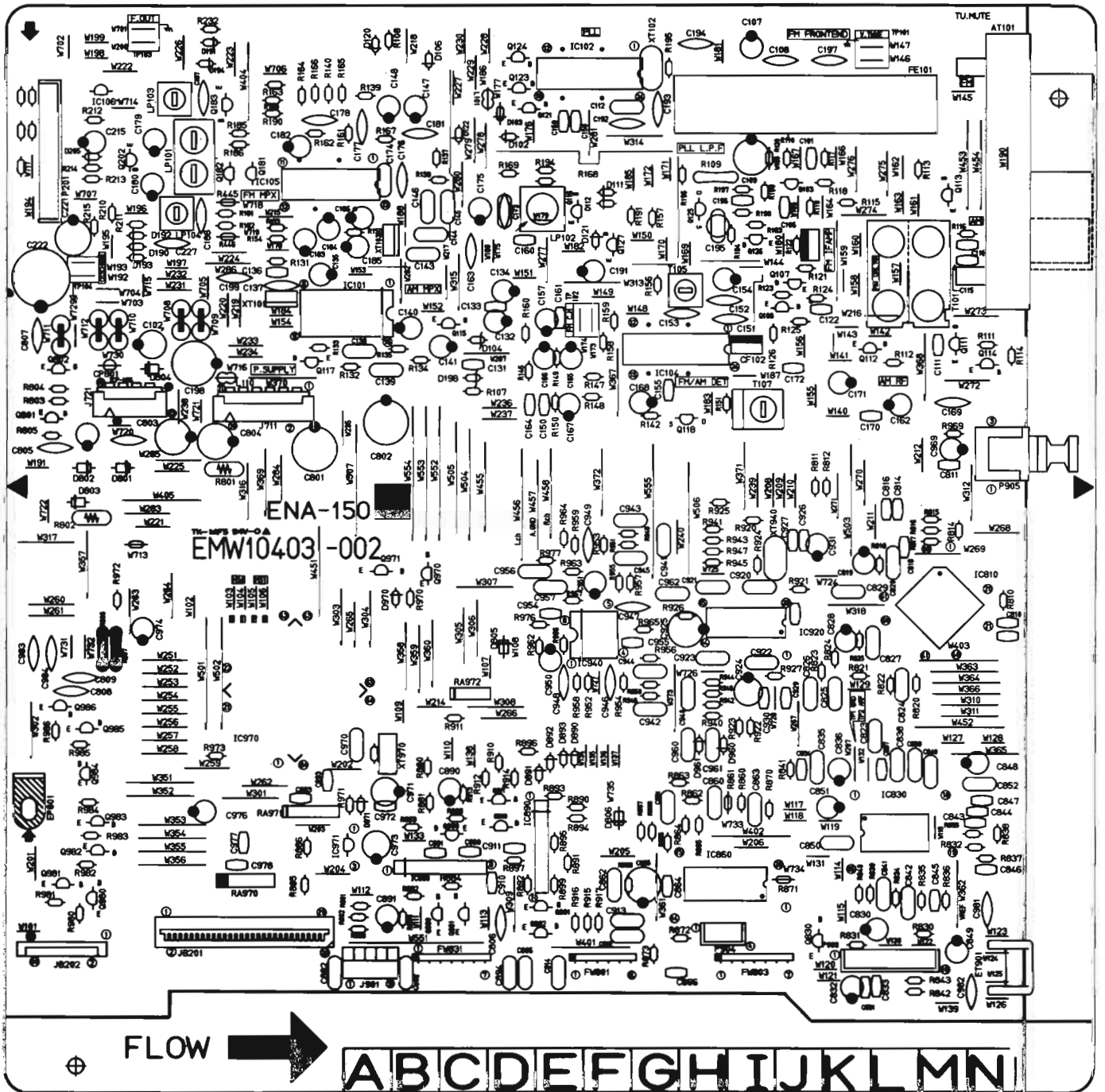

TRANSISTORS

Δ	ITEM	PART NUMBER	DESCRIPTION	AREA
	Q103	2SC461(B,C)	SI.TRANSISTHITACHI	
	Q107	2SC535(B,C)	SI.TRANSIST	
	Q108	2SC461(B,C)	SI.TRANSISTHITACHI	
	Q115	DTA144ES	DIGITAL TRAROHM	
	Q116	DTC114YS	DIGITAL TRAROHM	
	Q117	DTC114YS	DIGITAL TRAROHM	
	Q118	2SK301(P,Q)	F.E.T. MATSUSHITA	
	Q123	DTA144ES	DIGITAL TRAROHM	
	Q124	DTA144ES	DIGITAL TRAROHM	
	Q125	2SK301(Q2)	F.E.T.	
	Q126	2SC3311A(Q,R)	SI.TRANSISTMATSUSHITA	
	Q181	2SD2144S(VW)	SI.TRANSISTROHM	
	Q182	2SD2144S(VW)	SI.TRANSISTROHM	
	Q183	DTA144ES	DIGITAL TRAROHM	
	Q801	2SA934(Q,R)	SI.TRANSISTROHM	
	Q802	DTA144ES	DIGITAL TRAROHM	
	Q880	2SC2060(Q,R)	SI.TRANSISTROHM	
	Q881	2SA934(Q,R)	SI.TRANSISTROHM	
	Q890	DTC144ES	DIGITAL TRAROHM	
	Q891	2SC2060(Q,R)	SI.TRANSISTROHM	
	Q892	2SA934(Q,R)	SI.TRANSISTROHM	
	Q910	2SC2060(Q,R)	SI.TRANSISTROHM	
	Q911	2SA934(Q,R)	SI.TRANSISTROHM	
	Q970	DTA114YS	DIGITAL TRAROHM	
	Q971	DTC114YS	DIGITAL TRAROHM	
	Q980	DTC114YS	DIGITAL TRAROHM	
	Q981	DTC114YS	DIGITAL TRAROHM	
	Q982	DTC114YS	DIGITAL TRAROHM	
	Q983	DTC114YS	DIGITAL TRAROHM	
	Q984	DTC114YS	DIGITAL TRAROHM	
	Q985	DTC114YS	DIGITAL TRAROHM	
	Q986	DTC114YS	DIGITAL TRAROHM	

Δ : DISAPPEARING PARTS

I. C. S.

Δ	ITEM	PART NUMBER	DESCRIPTION	AREA
	IC101	TAB124P	I.C.(MONO-ANTOSHIBA	
	IC102	LC7218	I.C.(DIGI-MO	
	IC104	LA1266A	I.C.(MONO-ANSANYO	
	IC105	LA3401	I.C.(MONO-ANSANYO	
	IC810	MN662720RB	I.C.(DIGI-MOMATSUSHITA	
	IC830	AN8803SB	I.C.(MONO-ANMATSUSHITA	
	IC860	BA6393FP	I.C.(MONO-ANROHM	
	IC880	MS218AL	I.C.(MONO-ANMITSUBISHI	
	IC890	MS218AL	I.C.(MONO-ANMITSUBISHI	
	IC920	MN35502	I.C.	
	IC940	XRA15218	I.C.(MONO-ANROHM	
	IC970	MN172412JHS1	I.C.	
	IC971	MN1281(P,Q)	I.C.(DIGI-MOMATSUSHITA	

Δ : DISAPPEARING PARTS

DIODES

Δ	ITEM	PART NUMBER	DESCRIPTION	AREA
	D104	MTZ8.2JC	ZENER DIODEROHM	
	D106	1SS133	SI.DIODE ROHM	
	D111	1SS133	SI.DIODE ROHM	
	D112	1SS133	SI.DIODE ROHM	
	D120	1SS133	SI.DIODE ROHM	
	D122	1SS133	SI.DIODE ROHM	
	D190	1SS133	SI.DIODE ROHM	
	D191	1SS133	SI.DIODE ROHM	
	D193	1SS133	SI.DIODE ROHM	
	D194	1SS133	SI.DIODE ROHM	
	D198	MTZ5.1JC	ZENER DIODEROHM	
	D801	1SR139-200	SI.DIODE ROHM	
	D802	1SR139-200	SI.DIODE ROHM	
	D803	1SR139-200	SI.DIODE ROHM	
	D804	1SR139-200	SI.DIODE ROHM	
	D805	1SR139-200	SI.DIODE ROHM	
	D806	1SR139-200	SI.DIODE ROHM	
	D890	1SS119	SI.DIODE	
	D891	1SS119	SI.DIODE	
	D892	1SS119	SI.DIODE	
	D893	1SS119	SI.DIODE	
	D960	1SS119	SI.DIODE	
	D961	1SS119	SI.DIODE	
	D970	1SS119	SI.DIODE	
	D971	1SS119	SI.DIODE	

Δ : DISAPPEARING PARTS

CAPACITORS

Δ	ITEM	PART NUMBER	DESCRIPTION	AREA
	C101	QCHB1EZ-223	0.022MF 25V CER.CAPACI TO	
	C102	QETBOJM-227	220MF 6.3V E.CAPACITO R	
	C106	QCHB1EZ-223	0.022MF 25V CER.CAPACI TO	
	C108	QCF21HP-103A	0.01MF 50V CER.CAPACI TO	
	C109	QETB1CM-227	220MF 16V AL E.CAPAC IT	
	C112	QCZ0202-155	1.5MF 25V CER.RESIST OR	
	C115	QCHB1EZ-223	0.022MF 25V CER.CAPACI TO	
	C116	QCT30CH-120	12PF 50V CERAMIC	
	C122	QCHB1EZ-223	0.022MF 25V CER.CAPACI TO	
	C131	QCHB1EZ-223	0.022MF 25V CER.CAPACI TO	
	C132	QETB1HM-224	0.22MF 50V AL E.CAPAC IT	
	C133	QCHB1EZ-223	0.022MF 25V CER.CAPACI TO	
	C134	QETB1HM-475	4.7MF 50V AL E.CAPAC IT	
	C135	QETB1CM-107	100MF 16V AL E.CAPAC IT	
	C136	QCVB1CM-103Y	0.01MF 16V CER.CAPACI TO	
	C137	QCT26CH-180	18PF 50V CER.CAPACI TO	
	C138	QFV81HJ-473	0.047MF 50V THIN FILM CA	
	C139	QFV81HJ-473	0.047MF 50V THIN FILM CA	
	C140	QETB1HM-475	4.7MF 50V AL E.CAPAC IT	
	C141	QETB1CM-107	100MF 16V AL E.CAPAC IT	
	C143	QFLB1HJ-473	0.047MF 50V MYLAR CAPA CI	
	C144	QFLB1HJ-473	0.047MF 50V MYLAR CAPA CI	
	C145	QFLB1HJ-473	0.047MF 50V MYLAR CAPA CI	
	C146	QFLB1HJ-473	0.047MF 50V MYLAR CAPA CI	
	C147	QETB1HM-475	4.7MF 50V AL E.CAPAC IT	
	C148	QETB1HM-475	4.7MF 50V AL E.CAPAC IT	
	C150	QCHB1EZ-223	0.022MF 25V CER.CAPACI TO	
	C151	QCF21HP-223A	0.022MF 50V CER.CAPACI TO	
	C152	QCF21HP-223A	0.022MF 50V CER.CAPACI TO	
	C153	QCC21EM-223	0.022MF 25V CER.CAPACI TO	
	C155	QCHB1EZ-223	0.022MF 25V CER.CAPACI TO	
	C157	QETB1HM-474	0.47MF 50V ELECTRO	
	C158	QCBB1HK-101Y	100PF 50V CER.CAPACI TO	
	C159	QCBB1HK-101Y	100PF 50V CER.CAPACI TO	
	C160	QCBB1HK-221Y	220PF 50V CER.CAPACI TO	
	C161	QCHB1EZ-223	0.022MF 25V CER.CAPACI TO	
	C162	QETB1HM-106	10MF 50V E.CAPACITO R	
	C164	QCHB1EZ-223	0.022MF 25V CER.CAPACI TO	
	C165	QETB1HM-474	0.47MF 50V ELECTRO	
	C166	QETB1HM-225	2.2MF 50V E.CAPACITO R	
	C167	QETB1HM-106	10MF 50V E.CAPACITO R	
	C168	QETB1EM-226	22MF 25V E.CAPACITO R	
	C169	QCF21HP-223A	0.022MF 50V CER.CAPACI TO	
	C170	QCHB1EZ-223	0.022MF 25V CER.CAPACI TO	
	C171	QETB1HM-106	10MF 50V E.CAPACITO R	
	C172	QCVB1CM-103Y	0.01MF 16V CER.CAPACI TO	
	C173	QCF21HP-223A	0.022MF 50V CER.CAPACI TO	
	C174	QFLB1HK-473	0.047MF 50V MYLAR CAPA CI	
	C175	QETB1HM-106	10MF 50V E.CAPACITO R	
	C176	QCY21HK-102	1000PF 50V CER.CAPACI TO	
	C177	QCS21HJ-561	560PF 50V CER.CAPACI TO	
	C178	QCS21HJ-561	560PF 50V CER.CAPACI TO	
	C179	QETB1HM-225	2.2MF 50V E.CAPACITO R	
	C180	QETB1HM-225	2.2MF 50V E.CAPACITO R	
	C181	QCF21HP-473A	0.047MF 50V CER.CAPACI TO	
	C182	QETB1HM-225	2.2MF 50V E.CAPACITO R	
	C183	QETB1HM-105	1MF 50V AL E.CAPAC IT	
	C184	QETB1HM-105	1MF 50V AL E.CAPAC IT	
	C185	QETB1HM-225	2.2MF 50V E.CAPACITO R	
	C186	QETB1HM-474	0.47MF 50V ELECTRO	
	C187	QCY31HK-332Z	3300PF 50V CER.CAPACI TO	
	C188	QCY31HK-332Z	3300PF 50V CER.CAPACI TO	
	C191	QETB1HM-475	4.7MF 50V AL E.CAPAC IT	
	C192	QCC21EM-473	0.047MF 25V CER.CAPACI TO	
	C193	QCS21HJ-180A	18PF 50V CER.CAPACI TO	
	C194	QCS21HJ-180A	18PF 50V CER.CAPACI TO	
	C195	QFV81HJ-474	0.047MF 50V THIN FILM CA	
	C196	QCGB1HK-102	1000PF 50V CER.CAPACI TO	
	C197	QCF21HP-223A	0.022MF 50V CER.CAPACI TO	
	C198	QETB1CM-477	470MF 16V AL E.CAPAC IT	
	C199	QCF21HP-103A	0.01MF 50V CER.CAPACI TO	
	C221	QETB1AM-477	470MF 10V E.CAPACITO R	
	C222	QEA40HZ-10AB	E.CAPACITO R	
	C227	QCF21HP-103A	0.01MF 50V CER.CAPACI TO	
	C801	QETB1CM-108N	1000MF 16V E.CAPACITO R	
	C802	QETB1CM-108N	1000MF 16V E.CAPACITO R	
	C803	QETB1CM-227	220MF 16V AL E.CAPAC IT	
	C804	QETB1CM-227	220MF 16V AL E.CAPAC IT	
	C805	QCF21HP-223A	0.022MF 50V CER.CAPACI TO	
	C806	QCF21HP-223A	0.022MF 50V CER.CAPACI TO	
	C807	QCF21HP-223A	0.022MF 50V CER.CAPACI TO	
	C810	QCHB1EZ-223	0.022MF 25V CER.CAPACI TO	
	C811	QCT30CH-5R6	5.6PF 50V CERAMIC	
	C818	QCT30CH-8R2	8.2PF 50V CERAMIC	
	C819	QETB1AM-107	100MF 10V AL E.CAPAC IT	
	C820	QFV81HJ-104	0.1MF 50V THIN FILM CA	
	C823	QCS21HJ-181	180PF 50V CERAMIC	
	C824	QFLB1HJ-223	0.022MF 50V MYLAR CAPA CI	
	C825	QFV81HJ-104	0.1MF 50V THIN FILM CA	
	C826	QFV81HJ-334	0.33MF 50V TF.CAPACIT OR	
	C827	QFV81HJ-104	0.1MF 50V THIN FILM CA	
	C828	QETB1AM-107	100MF 10V AL E.CAPAC IT	
	C829	QFLB1HJ-223	0.022MF 50V MYLAR CAPA CI	
	C830	QETB1AM-476	47MF 10V E.CAPACITO R	
	C831	QCHB1EZ-223	0.022MF 25V CER.CAPACI TO	

Δ : DISAPPEARING PARTS

CAPACITORS

RESISTORS

Table with 5 columns: ITEM, PART NUMBER, DESCRIPTION, AREA. Lists various capacitor specifications such as QETB1AM-476, QCHB1EZ-223, QCS21HJ-221, etc.

△ : ISAFETY PARTS

Table with 5 columns: ITEM, PART NUMBER, DESCRIPTION, AREA. Lists various resistor specifications such as QRD167J-393, QRD167J-394, QRD167J-683, etc.

△ : ISAFETY PARTS

CAPACITORS

Table with 5 columns: ITEM, PART NUMBER, DESCRIPTION, AREA. Lists capacitor specifications such as QRD167J-222, QRD167J-472, QRD167J-104, etc.

△ : ISAFETY PARTS

RESISTORS

Δ	ITEM	PART NUMBER	DESCRIPTION			AREA
	R883	QRD167J-473	47K	1/6W	CARBON RES	IS
	R884	QRD161J-221	220	1/6W	CARBON RES	IS
	R885	QRD161J-221	220	1/6W	CARBON RES	IS
	R886	QRD161J-221	220	1/6W	CARBON RES	IS
	R890	QRD167J-153	15K	1/6W	CARBON RES	IS
	R891	QRD167J-123	12K	1/6W	CARBON RES	IS
	R892	QRD167J-393	39K	1/6W	CARBON RES	IS
	R893	QRD167J-103	10K	1/6W	CARBON RES	IS
	R894	QRD161J-273	27K	1/6W	CARBON RES	IS
	R895	QRD167J-223	22K	1/6W	CARBON RES	IS
	R896	QRD167J-473	47K	1/6W	CARBON RES	IS
	R897	QRD161J-752	7.5K	1/6W	CARBON RES	IS
	R898	QRD161J-303Y	30K	1/6W	CARBON RES	IS
	R899	QRD161J-221	220	1/6W	CARBON RES	IS
	R900	QRD167J-102	1K	1/6W	CARBON RES	IS
	R901	QRD167J-102	1K	1/6W	CARBON RES	IS
	R902	QRD167J-102	1K	1/6W	CARBON RES	IS
	R903	QRD167J-102	1K	1/6W	CARBON RES	IS
	R910	QRD167J-243	24K	1/6W	CARBON RES	IS
	R911	QRD161J-183	18K	1/6W	CARBON RES	IS
	R912	QRD161J-183	18K	1/6W	CARBON RES	IS
	R913	QRD161J-163	16K	1/6W	CARBON RES	IS
	R914	QRD161J-820	82	1/6W	CARBON RES	IS
	R915	QRD167J-102	1K	1/6W	CARBON RES	IS
	R916	QRD167J-102	1K	1/6W	CARBON RES	IS
	R917	QRD167J-102	1K	1/6W	CARBON RES	IS
	R920	QRD161J-101	100	1/6W	CARBON RES	IS
	R921	QRD167J-102	1K	1/6W	CARBON RES	IS
	R922	QRD167J-560	56	1/6W	CARBON RES	IS
	R923	QRD167J-560	56	1/6W	CARBON RES	IS
	R924	QRD167J-271	270	1/6W	CARBON RES	IS
	R925	QRD161J-101	100	1/6W	CARBON RES	IS
	R926	QRD161J-122	1.2K	1/6W	CARBON RES	IS
	R927	QRD161J-561	560	1/6W	CARBON RES	IS
	R940	QRD167J-363	36K	1/6W	CARBON	
	R941	QRD167J-363	36K	1/6W	CARBON	
	R942	QRD167J-363	36K	1/6W	CARBON	
	R943	QRD167J-363	36K	1/6W	CARBON	
	R944	QRD167J-363	36K	1/6W	CARBON	
	R945	QRD167J-363	36K	1/6W	CARBON	
	R946	QRD167J-363	36K	1/6W	CARBON	
	R947	QRD167J-363	36K	1/6W	CARBON	
	R948	QRD167J-153	15K	1/6W	CARBON RES	IS
	R949	QRD167J-153	15K	1/6W	CARBON RES	IS
	R950	QRD167J-153	15K	1/6W	CARBON RES	IS
	R951	QRD167J-153	15K	1/6W	CARBON RES	IS
	R952	QRD161J-362	3.6K	1/6W	CARBON RES	IS
	R953	QRD161J-362	3.6K	1/6W	CARBON RES	IS
	R954	QRD161J-362	3.6K	1/6W	CARBON RES	IS
	R955	QRD161J-362	3.6K	1/6W	CARBON RES	IS
	R956	QRD161J-333	33K	1/6W	CARBON RES	IS
	R957	QRD161J-333	33K	1/6W	CARBON RES	IS
	R958	QRD161J-333	33K	1/6W	CARBON RES	IS
	R959	QRD161J-333	33K	1/6W	CARBON RES	IS
	R962	QRD161J-331	330	1/6W	CARBON RES	IS
	R963	QRD161J-331	330	1/6W	CARBON RES	IS
	R964	QRD167J-271	270	1/6W	CARBON RES	IS
	R965	QRD167J-271	270	1/6W	CARBON RES	IS
	R966	QRD161J-273	27K	1/6W	CARBON RES	IS
	R967	QRD161J-273	27K	1/6W	CARBON RES	IS
	R969	QRD167J-2R2	2.2	1/6W	CARBON RES	IS
	R970	QRD167J-103	10K	1/6W	CARBON RES	IS
	R971	QRD161J-821	820	1/6W	CARBON RES	IS
	R972	QRD167J-473	47K	1/6W	CARBON RES	IS
	R973	QRD167J-103	10K	1/6W	CARBON RES	IS
	R980	QRD161J-221	220	1/6W	CARBON RES	IS
	R981	QRD161J-221	220	1/6W	CARBON RES	IS
	R982	QRD161J-221	220	1/6W	CARBON RES	IS
	R983	QRD161J-221	220	1/6W	CARBON RES	IS
	R984	QRD161J-221	220	1/6W	CARBON RES	IS
	R985	QRD161J-221	220	1/6W	CARBON RES	IS
	R986	QRD161J-221	220	1/6W	CARBON RES	IS
	RA970	QRB045J-472M	4.7K	1/8W	NETWORK RE	SI
	RA971	QRB069J-472	4.7K	1/10W	NETWORK RE	SI
	RA972	QRB049J-472	4.7K	1/10W	NETWORK RE	SI

Δ : SAFETY PARTS

OTHERS

Δ	ITEM	PART NUMBER	DESCRIPTION			AREA
		E308963-001	SHIELD BRACKET			
	J711	EMV7141-011	CONNECT TERMINAL 11PIN			
	J721	EMV7141-008M	CONNECT TERMINAL 8PIN			
	J901	EMV7122-005	MALE CONNECTOR5PIN			
	L110	EQL4004-2R2	INDUCTOR			
	P201	EMV5109-015A	PLUG ASSY15PIN			
	P903	EMV5109-010A	CONNECT TERMINAL 10PIN			
	P904	EMV5109-004A	MALE CONNECTOR4PIN			
	P905	GP1F32T	OPTICAL JACK			
	T101	EQ7121-005	RF COIL			
	T105	EQ72140-017	I.F.TRANSFORMER			
	T107	ECB1560-011	CERAMIC FILTER			
	AT101	EMB41YV-302K	ANTENNA TERMINAL			
	CF101	ECB2123-006R	CERAMIC FILTER			
	CF102	ECB2123-006R	CERAMIC FILTER			
	CP801	ICP-N15	I.C.PROTECTOR			
Δ	EP801	EMZ4002-001Z	EARTH PLATE			
	ET901	E70225-001	EARTH PLATE			
	FE101	EAF6102-001	FRONT END			
	FWB01	EWR368-16KST	FLAT WIRE ASSY6PIN			
	FWB03	EWR378-16KST	FLAT WIRE ASSY7PIN			
	FWB31	EWR378-16KST	FLAT WIRE ASSY7PIN			
	JB201	EMV7123-029	MALE CONNECTOR29PIN			
	JB202	EMV7144-015	F.P.C.PLUG15PIN			
	LP103	EQF0101-010	LOWPASS FILTER			
	LP104	EQF0101-010	LOWPASS FILTER			
	XT101	ECX0003-600KRDT	RESONATOR			
	XT102	ECX0007-200KC	CRYSTAL			
	XT103	ECX0000-456KR	CERAMIC RESONATOR			
	XT940	ECX0169-344EA	CRYSTAL			
	XT970	ECX0060-000EM	CERAMIC RESONATOR			

Δ : SAFETY PARTS

■ ENB-181 B CD PC Board Ass'y

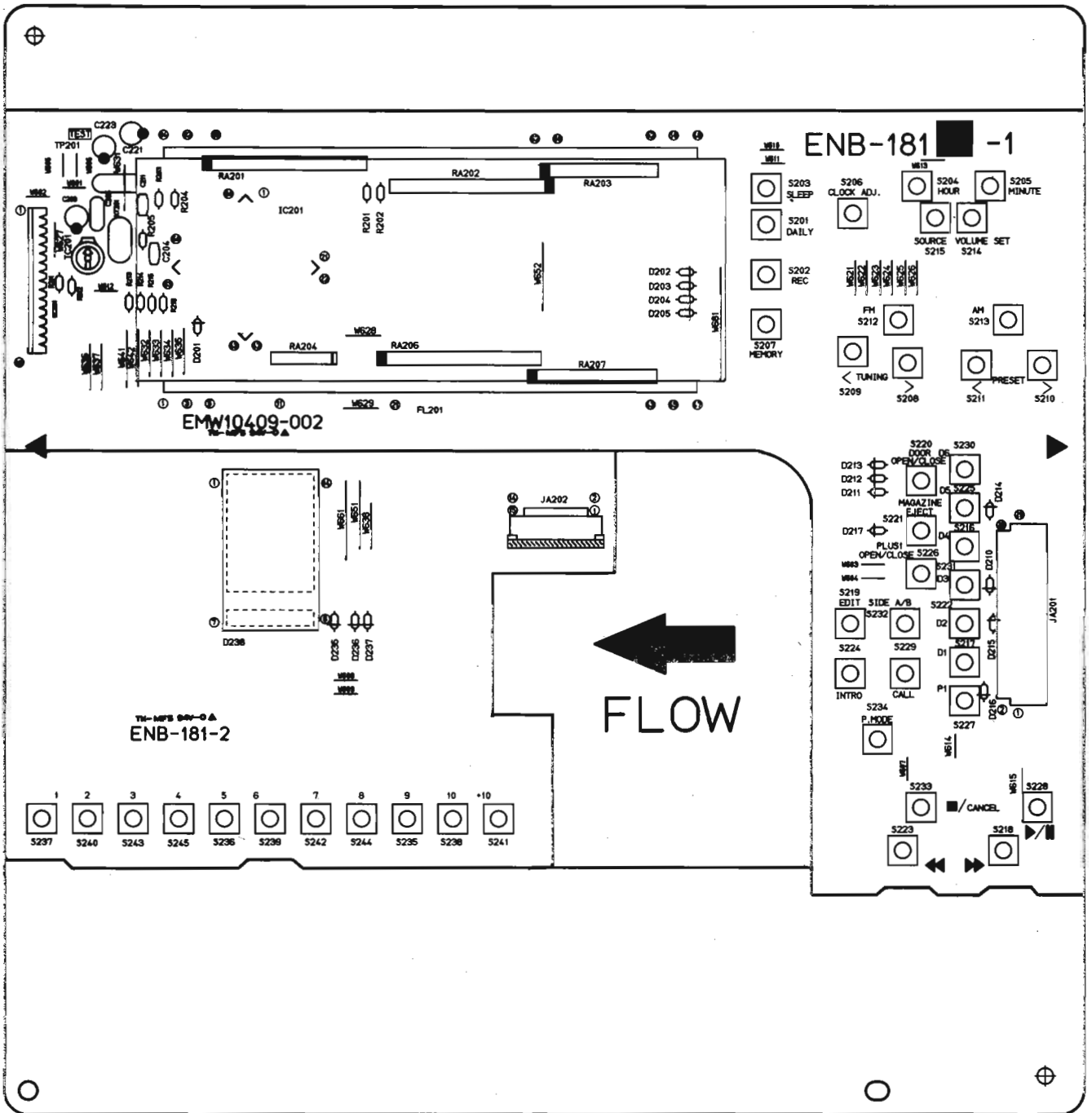

I. C. S.

ITEM	PART NUMBER	DESCRIPTION	AREA
IC201	MN172412JHR1	I.C.	

△ SAFETY PARTS

DIODES

ITEM	PART NUMBER	DESCRIPTION	AREA
D201	1SS119	SI. DIODE	
D202	1SS119	SI. DIODE	
D203	1SS119	SI. DIODE	
D204	1SS119	SI. DIODE	
D205	1SS119	SI. DIODE	
D210	1SS119	SI. DIODE	
D211	1SS119	SI. DIODE	
D212	1SS119	SI. DIODE	
D213	1SS119	SI. DIODE	
D214	1SS119	SI. DIODE	
D215	1SS119	SI. DIODE	
D216	1SS119	SI. DIODE	
D217	1SS119	SI. DIODE	
D235	1SS119	SI. DIODE	
D236	1SS119	SI. DIODE	
D237	1SS119	SI. DIODE	
D238	LS-021VP	L.E.D. ROHM	

△ SAFETY PARTS

CAPACITORS

ITEM	PART NUMBER	DESCRIPTION	AREA
C203	QCT30CH-180	18PF 50V CERAMIC	
C204	QCT30CH-150	15PF 50V CERAMIC	
C205	QCZ0205-155	1.5MF 25V C. CAPACITOR	
C208	QETB1HM-226	22MF 50V AL. E. CAPACIT	
C211	QCVB1CM-103Y	0.01MF 16V CER. CAPACIT	
C221	QETB1HM-106	10MF 50V E. CAPACIT	
C223	QETB1HM-106	10MF 50V E. CAPACIT	

△ SAFETY PARTS

RESISTORS

ITEM	PART NUMBER	DESCRIPTION	AREA
R201	QRD167J-104	100K 1/6W CARBON RES IS	
R202	QRD167J-104	100K 1/6W CARBON RES IS	
R203	QRD167J-104	100K 1/6W CARBON RES IS	
R204	QRD167J-104	100K 1/6W CARBON RES IS	
R213	QRD167J-222	2.2K 1/6W CARBON RES IS	
R214	QRD167J-222	2.2K 1/6W CARBON RES IS	
R215	QRD167J-222	2.2K 1/6W CARBON RES IS	
R216	QRD167J-222	2.2K 1/6W CARBON RES IS	
RA201	QRB135J-104	100K 1/8W NETWORK RE SI	

△ SAFETY PARTS

RESISTORS

ITEM	PART NUMBER	DESCRIPTION	AREA
RA202	QRB135J-104	100K 1/8W NETWORK RE SI	
RA203	QRB095J-104	100K 1/8W NETWORK RE SI	
RA204	QRB079J-104	100K 1/10W NETWORK RE SI	
RA206	QRB135J-104	100K 1/8W NETWORK RE SI	
RA207	QRB105J-104	100K 1/8W RESISTOR ARR	

△ SAFETY PARTS

OTHERS

ITEM	PART NUMBER	DESCRIPTION	AREA
S201	VYH7653-001	SPRING	
S202	ESP0001-023M	TACT SWITCHDAILY	
S203	ESP0001-023M	TACT SWITCHREC	
S204	ESP0001-023M	TACT SWITCHMEMORY	
S205	ESP0001-023M	TACT SWITCHSLEEP	
S206	ESP0001-023M	TACT SWITCHCLOCKADJ	
S207	ESP0001-023M	TACT SWITCHSOURCE/REC TIME	
S208	ESP0001-023M	TACT SWITCHHOUR	
S209	ESP0001-023M	TACT SWITCHUP	
S210	ESP0001-023M	TACT SWITCHDOWN	
S211	ESP0001-023M	TACT SWITCHPRESET UP	
S212	ESP0001-023M	TACT SWITCHPRESET DOWN	
S213	ESP0001-023M	TACT SWITCHFM	
S214	ESP0001-023M	TACT SWITCHAM	
S215	ESP0001-023M	TACT SWITCHMINUTE	
S216	ESP0001-023M	TACT SWITCHVOLUME POSITION	
S217	ESP0001-023M	TACT SWITCHD4	
S218	ESP0001-023M	TACT SWITCHD1	
S219	ESP0001-023M	TACT SWITCHD2	
S220	ESP0001-023M	TACT SWITCHD3	
S221	ESP0001-023M	TACT SWITCHD5	
S222	ESP0001-023M	TACT SWITCHD6	
S223	ESP0001-023M	TACT SWITCHD7	
S224	ESP0001-023M	TACT SWITCHD8	
S225	ESP0001-023M	TACT SWITCHD9	
S226	ESP0001-023M	TACT SWITCHD10	
S227	ESP0001-023M	TACT SWITCHD11	
S228	ESP0001-023M	TACT SWITCHD12	
S229	ESP0001-023M	TACT SWITCHD13	
S230	ESP0001-023M	TACT SWITCHD14	
S231	ESP0001-023M	TACT SWITCHD15	
S232	ESP0001-023M	TACT SWITCHD16	
S233	ESP0001-023M	TACT SWITCHD17	
S234	ESP0001-023M	TACT SWITCHD18	
S235	ESP0001-023M	TACT SWITCHD19	
S236	ESP0001-023M	TACT SWITCHD20	
S237	ESP0001-023M	TACT SWITCHD21	
S238	ESP0001-023M	TACT SWITCHD22	
S239	ESP0001-023M	TACT SWITCHD23	
S240	ESP0001-023M	TACT SWITCHD24	
S241	ESP0001-023M	TACT SWITCHD25	
S242	ESP0001-023M	TACT SWITCHD26	
S243	ESP0001-023M	TACT SWITCHD27	
S244	ESP0001-023M	TACT SWITCHD28	
S245	ESP0001-023M	TACT SWITCHD29	
BC201	ENS26F-F220	SOCKET WIRE15PIN	
FL201	ELU0001-168	FLUORESCENT DISPLAY TUBE	
JA201	EMV7123-029R	PIN CONNECTOR29PIN	
JA202	EMV7144-015R	CONNECT TERMINAL15PIN	
TC201	ENZ1003-015	TRIMMER CAPACITOR	
XT201	ECX0006-000KNJ	CRYSTAL	

△ SAFETY PARTS

Accessories List

Part Number	Part Name	Q'ty	Description	Areas
E30580-2063A	INSTRUCTION BOOK	1		
EWP502-005K	BUILT-IN ANTENNA	1		
EQB4001-018	LOOP ANTENNA	1		
E308747-001	LOOP STAND	1		
EMZ2001-014	ADAPTOR PLUG	1		
ENZ2203-001	SIEMENS PLUG	1		
E26072-020	MAGAZINE	1		
E26078-001	TRAY	1		
UM-4NJ-2PSA	BATTERY	1		
RM-SEM30U	REMOTE CONTROLLER	1		
UR64EC1293A	BATTERY COVER	1		
E43486-519A	CAUTION SHEET	1		
EFW102-040	FLAT WARE ASSY	1		
QPGA025-03505	ENVELOPE	1		

△ SAFETY PARTS

Packing Materials and Part Numbers

Symbol No.

M	5	M	M
---	---	---	---

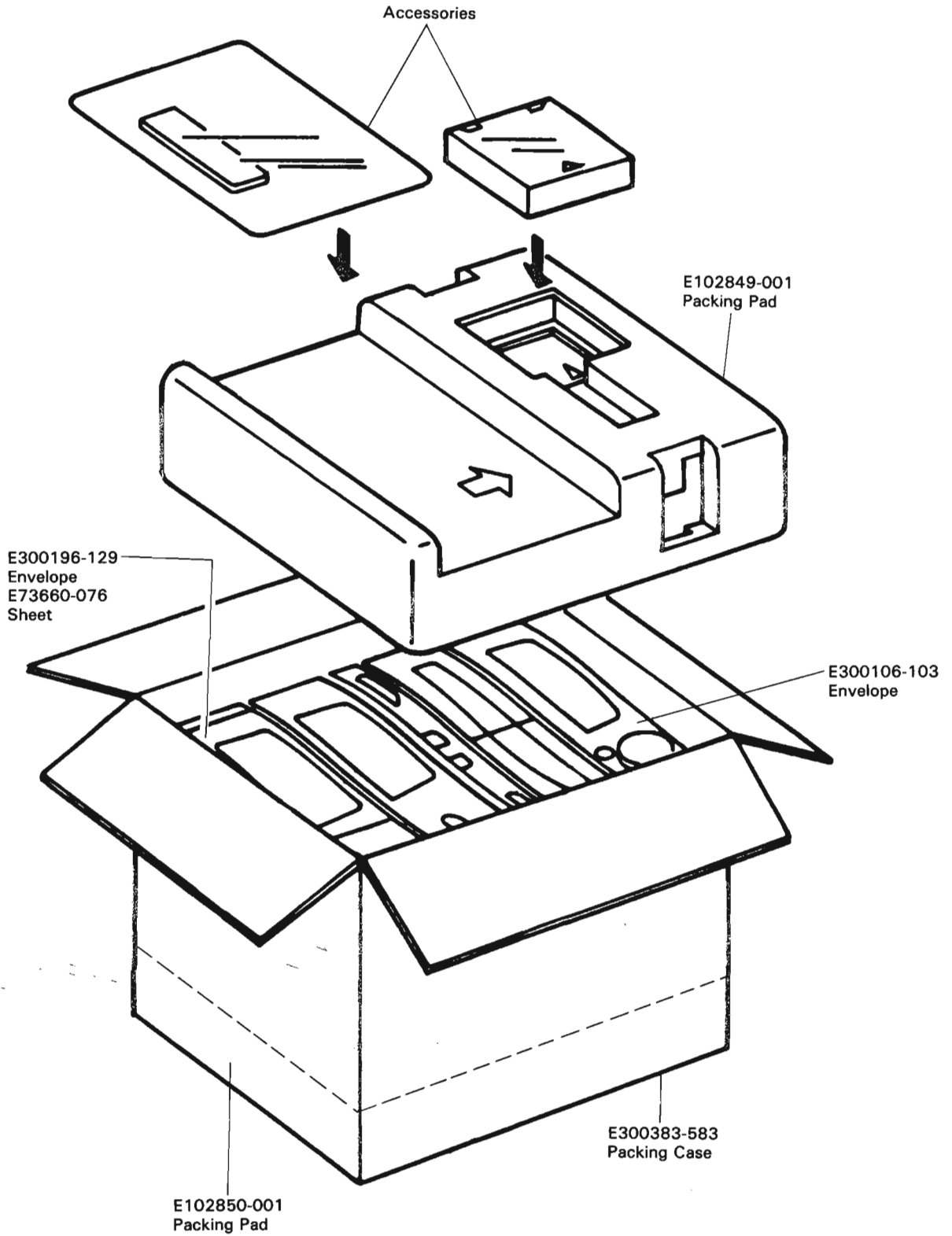

JVC

VICTOR COMPANY OF JAPAN, LIMITED
AUDIO DIVISION, YAMATO PLANT, 1644, SHIMOTSURUMA, YAMATO-SHI, KANAGAWA-KEN, 242, JAPAN